

Anybus[®] Wireless Bolt[™] Base Protector and Bracket

STARTUP GUIDE

SP2911

Version 1.2

Publication date 2024-07-17

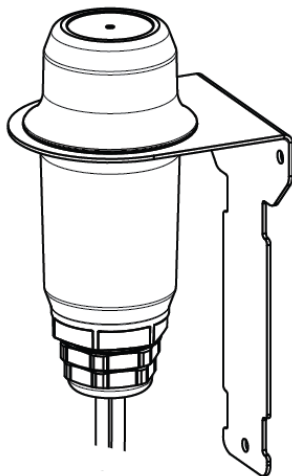

Important User Information

Disclaimer

The information in this document is for informational purposes only. Please inform HMS Networks of any inaccuracies or omissions found in this document. HMS Networks disclaims any responsibility or liability for any errors that may appear in this document.

HMS Networks reserves the right to modify its products in line with its policy of continuous product development. The information in this document shall therefore not be construed as a commitment on the part of HMS Networks and is subject to change without notice. HMS Networks makes no commitment to update or keep current the information in this document.

The data, examples and illustrations found in this document are included for illustrative purposes and are only intended to help improve understanding of the functionality and handling of the product. In view of the wide range of possible applications of the product, and because of the many variables and requirements associated with any particular implementation, HMS Networks cannot assume responsibility or liability for actual use based on the data, examples or illustrations included in this document nor for any damages incurred during installation of the product. Those responsible for the use of the product must acquire sufficient knowledge in order to ensure that the product is used correctly in their specific application and that the application meets all performance and safety requirements including any applicable laws, regulations, codes and standards. Further, HMS Networks will under no circumstances assume liability or responsibility for any problems that may arise as a result from the use of undocumented features or functional side effects found outside the documented scope of the product. The effects caused by any direct or indirect use of such aspects of the product are undefined and may include e.g. compatibility issues and stability issues.

Copyright © 2024 HMS Networks

Contact Information

Postal address:

Box 4126

300 04 Halmstad, Sweden

E-Mail: info@hms.se

1. Preface

1.1. About This Document

This guide describes the installation of the Bolt Base Protector and Bolt Bracket.

1.2. Document Conventions

Safety Symbols

**DANGER**

Instructions that must be followed to avoid an imminently hazardous situation which, if not avoided, will result in death or serious injury.

**WARNING**

Instructions that must be followed to avoid a potential hazardous situation that, if not avoided, could result in death or serious injury.

**CAUTION**

Instruction that must be followed to avoid a potential hazardous situation that, if not avoided, could result in minor or moderate injury.

**IMPORTANT**

Instruction that must be followed to avoid a risk of reduced functionality and/or damage to the equipment, or to avoid a network security risk.

Information Symbols



NOTE

Additional information which may facilitate installation and/or operation.



TIP

Helpful advice and suggestions.

1.3. Trademarks

Anybus® is a registered trademark of HMS Networks AB.

All other trademarks are the property of their respective holders.

2. Safety



CAUTION

To ensure proper functioning and electrical safety, connect the equipment to the Functional Earth (FE).



CAUTION

To minimize resistance and enhance safety and protection, use the shortest Functional Earth (FE) cable possible.



IMPORTANT

For information on how to install the Anybus Wireless Bolt safely and accurately, refer to the user manual for the specific Anybus Wireless Bolt product variant.



IMPORTANT

Use a power supply cable and a network cable with a proper round shape, for the cable gland split sealing insert to seal properly around the cables.



IMPORTANT

Ensure that the cables are properly secured to the cable gland, to avoid a pulling force on the cables.



IMPORTANT

When disassembling the cable gland parts and the cable gland sealing insert, ensure there is no twisting motion on the cables.

3. Preparation

3.1. Included in the Box

Table 1. Bolt Base Protector

Item	Pieces
Bolt Base Protector	1
O-ring	1
Cable gland	1
Cable gland o-ring	1
Cable gland split sealing insert for 2 cables.	1
Blind plug Used to seal unused hole in the Cable gland split sealing insert.	1

Table 2. Bolt Bracket

Item	Pieces
Bolt Bracket	1
Screw	3
Screw anchors	3
Stainless steel slim clamps for pole mount	2

3.2. Cabling

3.2.1. Anybus Wireless Bolt Cable Installation

**CAUTION**

To ensure proper functioning and electrical safety, connect the equipment to the Functional Earth (FE).

**CAUTION**

To minimize resistance and enhance safety and protection, use the shortest Functional Earth (FE) cable possible.

**IMPORTANT**

For information on how to install the Anybus Wireless Bolt safely and accurately, refer to the user manual for the specific Anybus Wireless Bolt product variant.

3.2.2. Cable Size

**IMPORTANT**

Use a power supply cable and a network cable with a proper round shape, for the cable gland split sealing insert to seal properly around the cables.

Recommended cable diameters to maintain IP rating:

- Ethernet cable: 6 ± 0.2 mm
- Power cable: 6 ± 0.2 mm
- Functional Earth (FE) wire, minimum cable area: $1,5 \text{ mm}^2$

3.2.3. Option When Using Three Separate Wires

There is a cable gland split sealing insert for 2 cables included in the box.

When using three separate wires, drill a third hole in the cable gland split sealing insert for the Functional Earth (FE) wire.

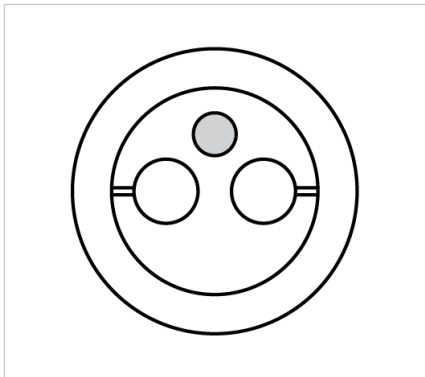

Figure 1. Cable gland split sealing insert with a hole for the Functional Earth (FE) wire

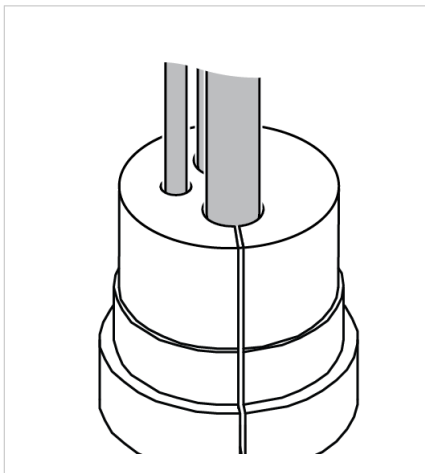
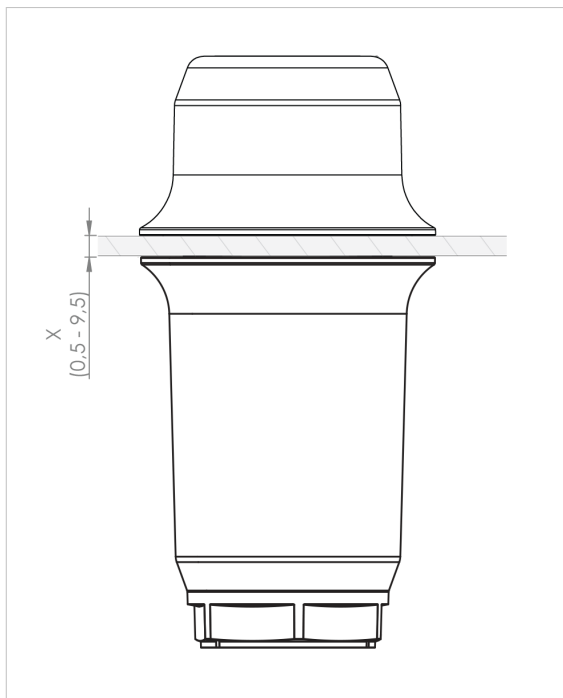

Figure 2. Cable gland split sealing insert with three cables

3.3. Mounting Surface



All measurements are in mm.

The thickness of the mounting surface must not exceed 10 mm.

3.4. Support and Resources

For information about how to install and configure the Bolt and for technical support, please visit www.hms-networks.com.

4. Base Protector Installation

Procedure

1. Unscrew and remove the Bolt lock nut.

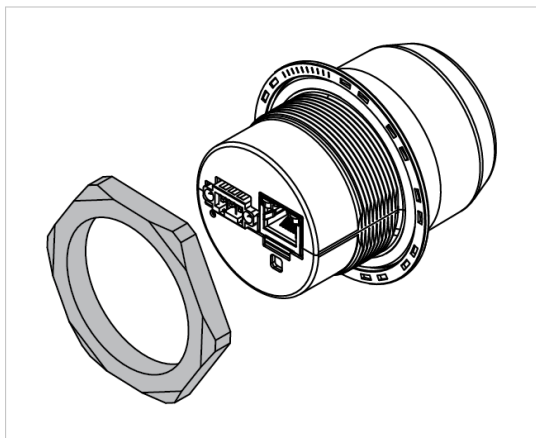

2. Optional step: Insert a SIM card into the Bolt SIM card holder.

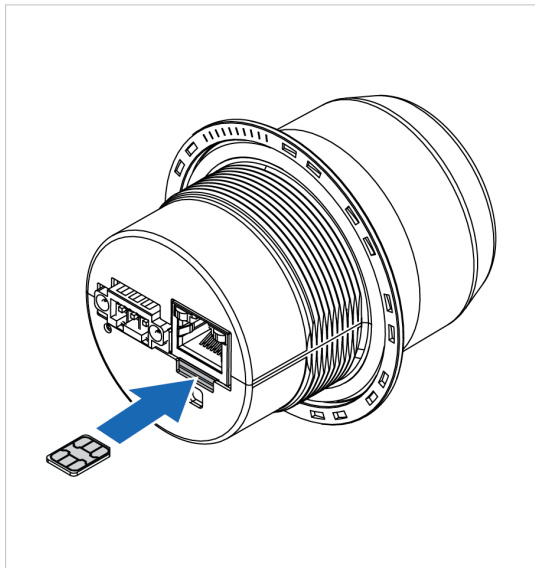

3. Ensure that the Bolt o-ring is correctly placed in the Bolt groove.

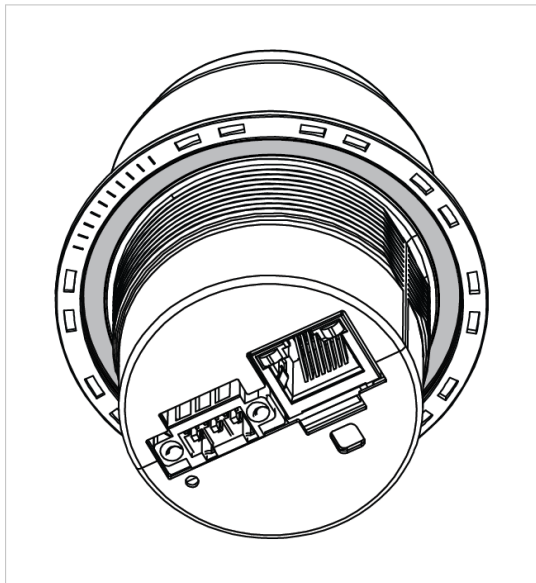

4. Place the Bolt in its mounting hole; in a surface or in the Bolt Bracket.

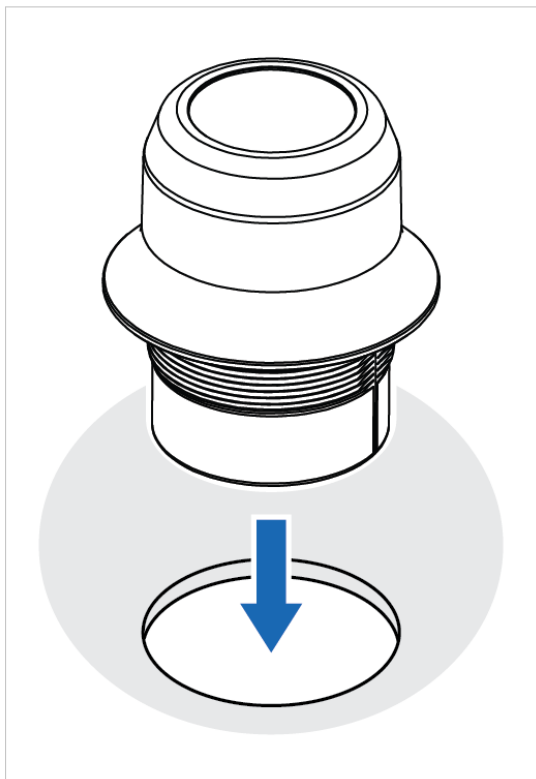

5. Attach the included o-ring to the Bolt Base Protector groove.

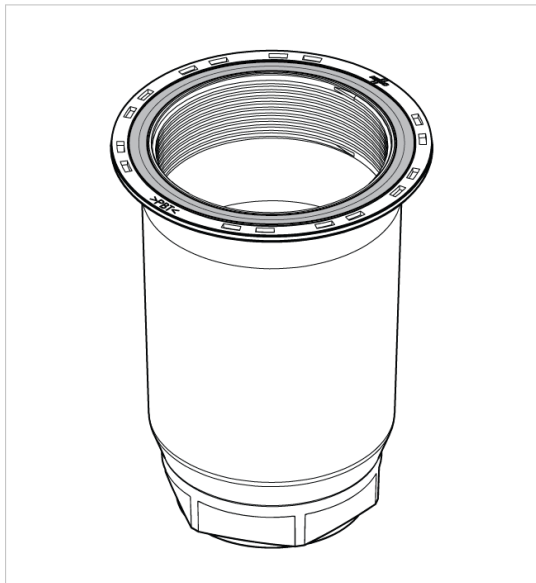

6. Attach the cable gland o-ring to the Bolt Base Protector bottom groove.

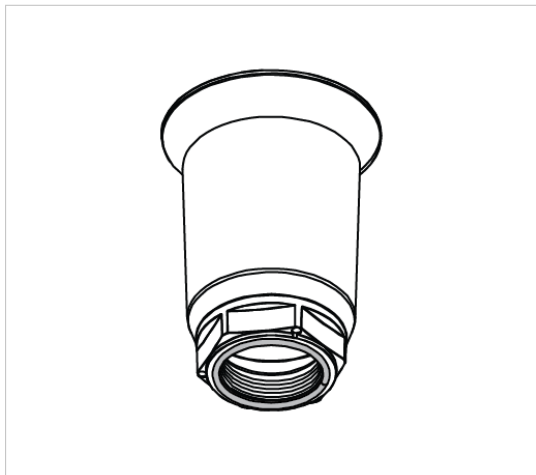

7. Unscrew the cable gland bottom from the cable gland top.

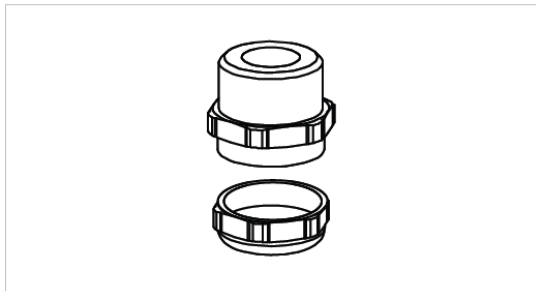

8. Attach the cable gland top to the Bolt Base Protector.
Tightening torque: 5 Nm



9. Pull the cables through the Bolt Base Protector and the cable gland parts.

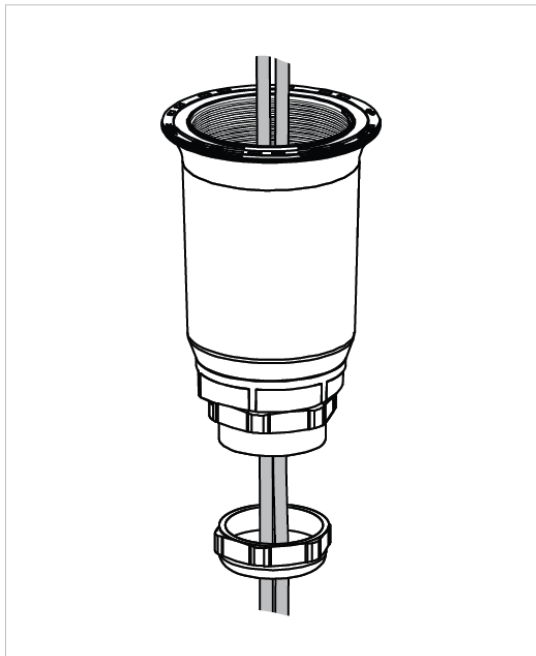

10. Connect the cables to the Bolt.

For information about the installation, refer to the Bolt Startup Guide.

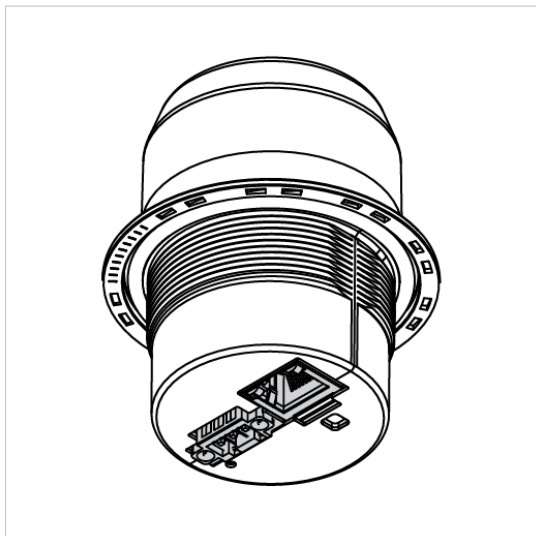

11. Attach the Bolt Base Protector to the Bolt.
Tightening torque: 5 Nm

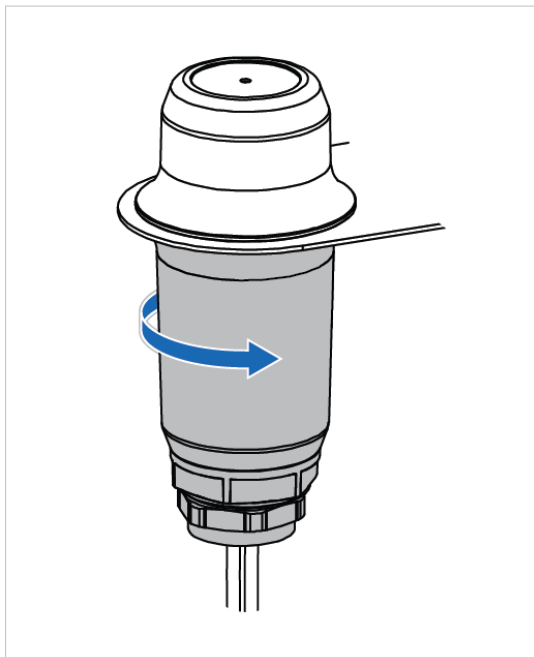

12. Open the slits and fit the cable gland sealing insert over the cables.

**NOTE**

If only one cable is used, ensure to seal the unused hole with the included blind plug.

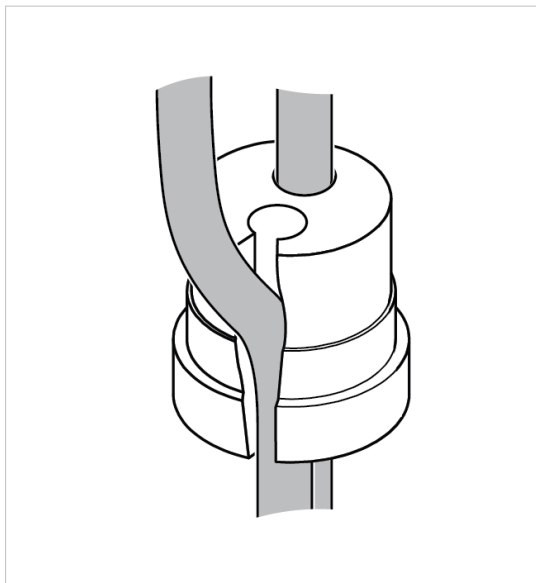

13. Attach the cable gland sealing insert to the cable gland top.

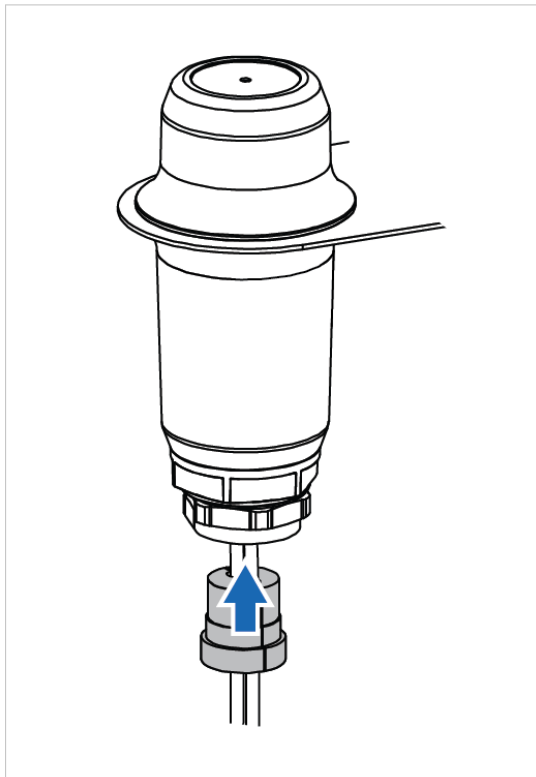

14. Attach the cable gland bottom to the cable gland top.
Only hand-tighten.

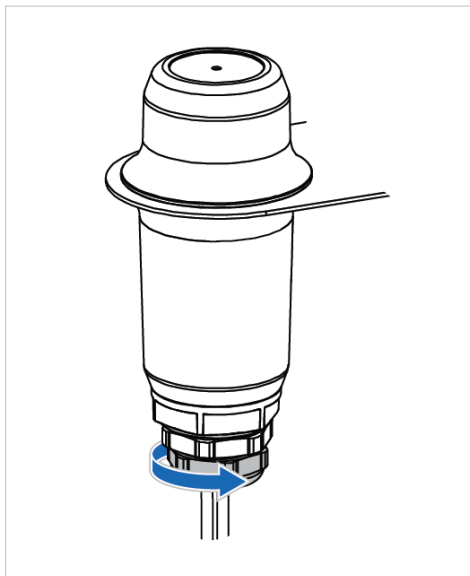

15. Check that the cable gland parts, the cable gland sealing insert and the cables are properly secured.

**IMPORTANT**

Ensure that the cables are properly secured to the cable gland, to avoid a pulling force on the cables.

5. Disassemble



IMPORTANT

When disassembling the cable gland parts and the cable gland sealing insert, ensure there is no twisting motion on the cables.

When disassembling, follow the [Base Protector Installation \(page 10\)](#) steps in the reverse order.

6. Bracket Pole Mounting

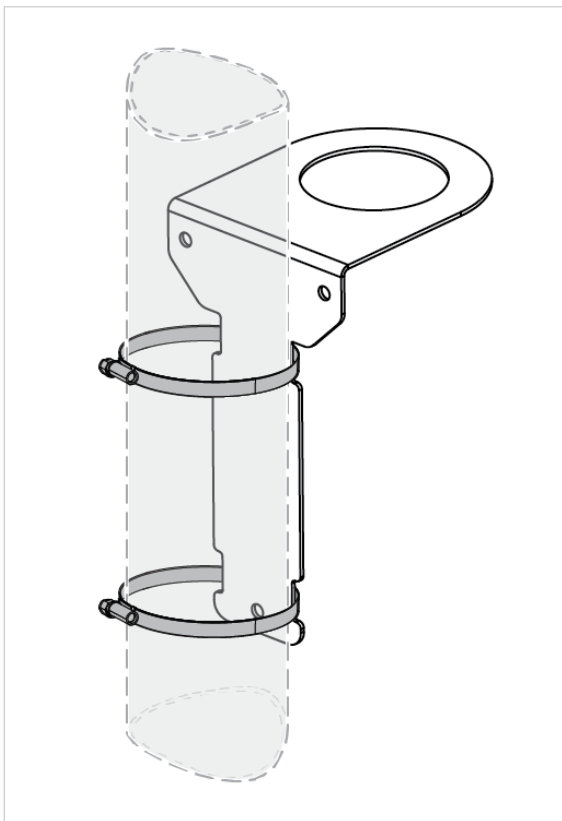

Procedure

1. Position the two included stainless steel slim clamps and the Bolt Bracket on the pole as needed.
2. Tighten the stainless steel slim clamps to the pole and lock them by tightening the screws.

**NOTE**

Ensure that the Bolt Bracket is firmly secured to the pole.

3. Remove any excess material from the stainless steel slim clamps.

7. Bracket Wall Mounting

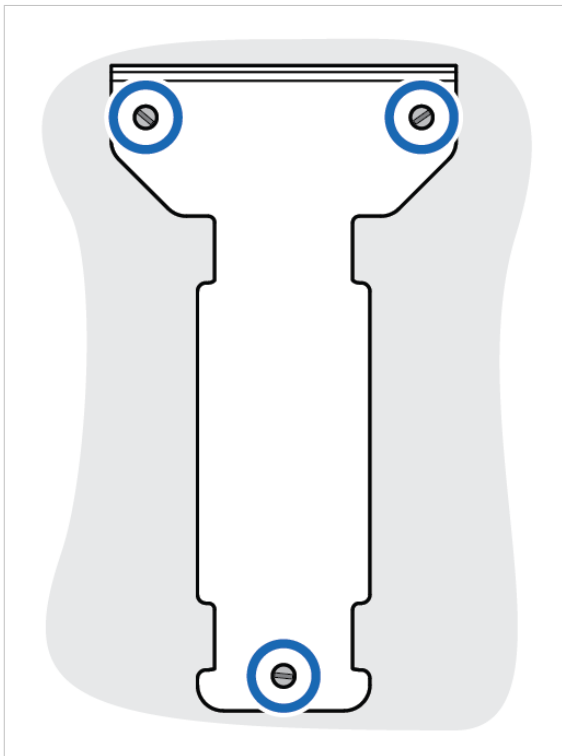

Procedure

1. Drill three holes in the wall and insert the included screw anchors.

**NOTE**

The included screw anchors are intended for use in concrete, stone or brick.

Drill hole size:

- Diameter: 8 mm
 - Depth: 45 mm
2. Use the three included screws to attach the Bolt Bracket to the wall.

8. Connect to Functional Earth (FE)

Connect the Functional Earth (FE) wire of the Anybus Wireless Bolt directly to stable ground, such as a pole or a wall/surface.

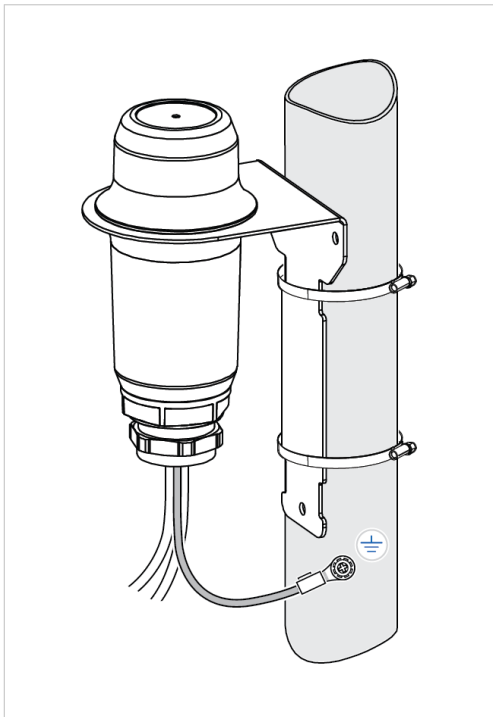

Example, functional earth wire screw placement on a pole.

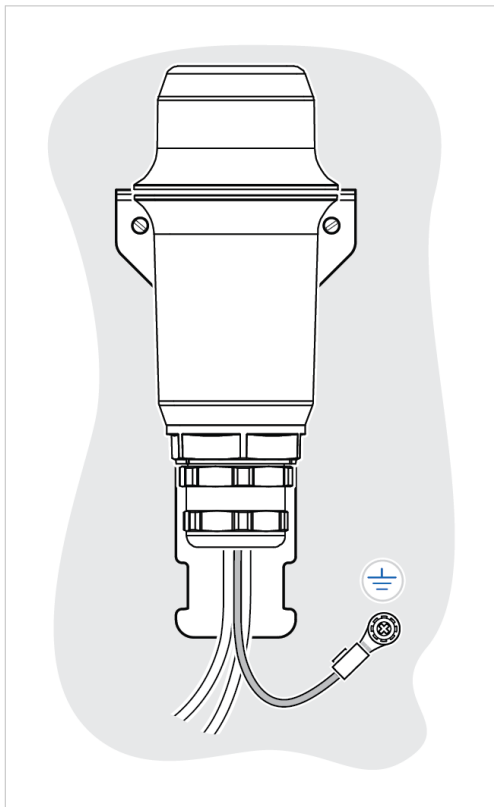

Example, functional earth wire screw placement on a wall/surface.

This page is intentionally left blank.

This page is intentionally left blank.

This page is intentionally left blank.