

Anybus[®] Wireless Bridge II Serial[™]

STARTUP GUIDE

SP2966

Version 1.4

Publication date 2022-02-23



Important User Information

Disclaimer

The information in this document is for informational purposes only. Please inform HMS Networks of any inaccuracies or omissions found in this document. HMS Networks disclaims any responsibility or liability for any errors that may appear in this document.

HMS Networks reserves the right to modify its products in line with its policy of continuous product development. The information in this document shall therefore not be construed as a commitment on the part of HMS Networks and is subject to change without notice. HMS Networks makes no commitment to update or keep current the information in this document.

The data, examples and illustrations found in this document are included for illustrative purposes and are only intended to help improve understanding of the functionality and handling of the product. In view of the wide range of possible applications of the product, and because of the many variables and requirements associated with any particular implementation, HMS Networks cannot assume responsibility or liability for actual use based on the data, examples or illustrations included in this document nor for any damages incurred during installation of the product. Those responsible for the use of the product must acquire sufficient knowledge in order to ensure that the product is used correctly in their specific application and that the application meets all performance and safety requirements including any applicable laws, regulations, codes and standards. Further, HMS Networks will under no circumstances assume liability or responsibility for any problems that may arise as a result from the use of undocumented features or functional side effects found outside the documented scope of the product. The effects caused by any direct or indirect use of such aspects of the product are undefined and may include e.g. compatibility issues and stability issues.

Copyright © 2021 HMS Networks

Contact Information

Postal address:

Box 4126

300 04 Halmstad, Sweden

E-Mail: info@hms.se

1. Preface

1.1. About This Document

This document describes how to install Anybus® Wireless Bridge II Serial™.

For additional documentation and software downloads, FAQs, troubleshooting guides and technical support, please visit www.anybus.com/support.

1.2. Document Conventions

Safety Symbols

**DANGER**

Instructions that must be followed to avoid an imminently hazardous situation which, if not avoided, will result in death or serious injury.

**WARNING**

Instructions that must be followed to avoid a potential hazardous situation that, if not avoided, could result in death or serious injury.

**CAUTION**

Instruction that must be followed to avoid a potential hazardous situation that, if not avoided, could result in minor or moderate injury.

**IMPORTANT**

Instruction that must be followed to avoid a risk of reduced functionality and/or damage to the equipment, or to avoid a network security risk.

Information Symbols

**NOTE**

Additional information which may facilitate installation and/or operation.

**TIP**

Helpful advice and suggestions.

1.3. Trademarks

Anybus® is a registered trademark and Wireless Bridge II Serial™ is a trademark of HMS Networks AB.

All other trademarks are the property of their respective holders.

2. Safety

2.1. General Safety

**CAUTION**

This equipment emits RF energy in the ISM (Industrial, Scientific, Medical) band. Make sure that all medical devices used in proximity to this equipment meet appropriate susceptibility specifications for this type of RF energy.

**CAUTION**

This equipment contains parts that can be damaged by electrostatic discharge (ESD). Use ESD prevention measures to avoid damage.

**CAUTION**

This equipment is recommended for use in both industrial and domestic environments. For industrial environments it is mandatory to use the functional earth connection to comply with immunity requirements. For domestic environments the functional earth must be used if a shielded Ethernet cable is used, in order to meet emission requirements.

2.2. External Antenna Restrictions

For models with external antenna, only use antennas that are certified for use with this equipment.

Using external antennas that are not certified for use with this equipment will invalidate its certifications and make it non-compliant with the regulations for radio equipment.

A list of certified antennas can be found at www.anybus.com/support.

2.3. Intended Use

The intended use of this equipment is as a communication interface and gateway. The equipment receives and transmits data on various physical levels and connection types.

If this equipment is used in a manner not specified by the manufacturer, the protection provided by the equipment may be impaired.

3. Preparation

3.1. Support and Resources

For additional documentation and software downloads, FAQs, troubleshooting guides and technical support, please visit www.anybus.com/support.

**TIP**

Have the product article number available, to search for the product specific support web page. You find the product article number on the product cover.

3.2. Optional Equipment

Bridge II Serial can be mounted on a standard DIN rail using the optional DIN mounting kit.

The DIN mounting kit is not included with the Bridge II Serial. For information about ordering the DIN mounting kit, please visit www.anybus.com.

3.3. Network Environment

Ensure that you have all the necessary information about the capabilities and restrictions of your local network environment before installation.

3.4. Placement

Antenna Considerations

For models with internal antenna the characteristics of the antenna should be considered when choosing the placement and orientation of the Bridge II Serial.

Required Distance Between Devices

For optimal reception, wireless devices require a zone between them clear of objects that could otherwise obstruct or reflect the signal. To avoid signal interference, a minimum distance of 50 cm between the devices should be observed.

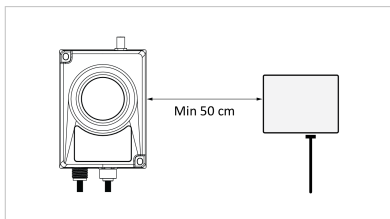

Figure 1. Required minimum distance between devices

3.5. When to Use Bluetooth or WLAN

Use Bluetooth when:

- The wireless link has an Anybus Wireless Bolt or Anybus Wireless Bridge II at both ends.
- An interruption-free connection is more important than data throughput speed.
- Interference robustness is important, e.g. in an industrial environment.

Use WLAN when:

- Connecting to other types of wireless devices or a WLAN infrastructure.
- High data throughput speed is more important than connection reliability.
- Large file transfers are expected.
- WLAN channel frequency planning is possible.

3.6. Bluetooth Limitations

Due to different implementations of Bluetooth by different manufacturers, Bluetooth PAN (Personal Area Network) may not work with some devices.

WLAN 5 GHz cannot be used at the same time as WLAN 2.4 GHz or Bluetooth.

4.2. Surface Mounting

Bridge II Serial can be screw-mounted directly onto a flat surface.

Before You Begin



NOTE

To avoid signal interference, a minimum distance of 50 cm between the devices should be observed. See also [Wireless Technology Basics](#).

Procedure

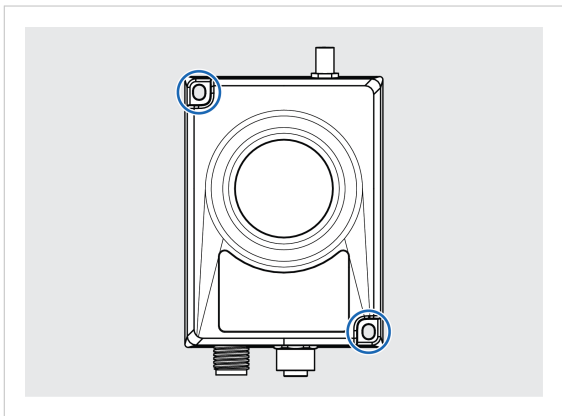

Figure 3. Surface mounting holes

- To screw-mount the Bridge II Serial on a surface, use the two holes (\varnothing 4 mm) at the corners of the Bridge II Serial.

4.3. DIN Rail Mounting

Using the optional DIN mounting kit, Bridge II Serial can be mounted on a standard DIN rail. See [Optional Equipment \(page 5\)](#).

Before You Begin

**NOTE**

To avoid signal interference, a minimum distance of 50 cm between the devices should be observed. See also [Wireless Technology Basics](#).

Procedure

To attach the Bridge II Serial on the DIN rail

1. Fasten the DIN clip with the 2 included screws on the rear side of the Bridge II Serial.

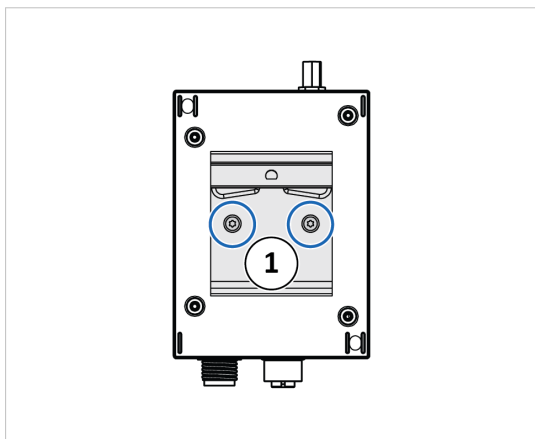

Figure 4. DIN clip on Bridge II Serial

2. Insert the upper end of the DIN rail clip into the DIN rail.

3. Push the bottom of the DIN rail clip into the DIN rail.

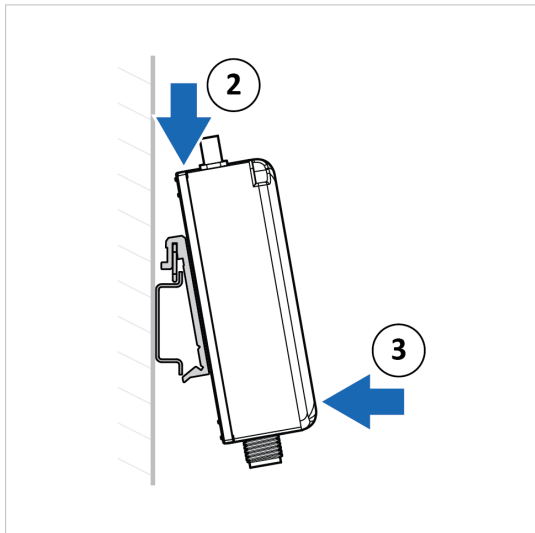

Figure 5. Attach Bridge II Serialon DIN rail

4.4. Connect to LAN, Serial and Power

Before You Begin



CAUTION

This equipment is recommended for use in both industrial and domestic environments. For industrial environments it is mandatory to use the functional earth connection to comply with immunity requirements. For domestic environments the functional earth must be used if a shielded Ethernet cable is used, in order to meet emission requirements.

Procedure

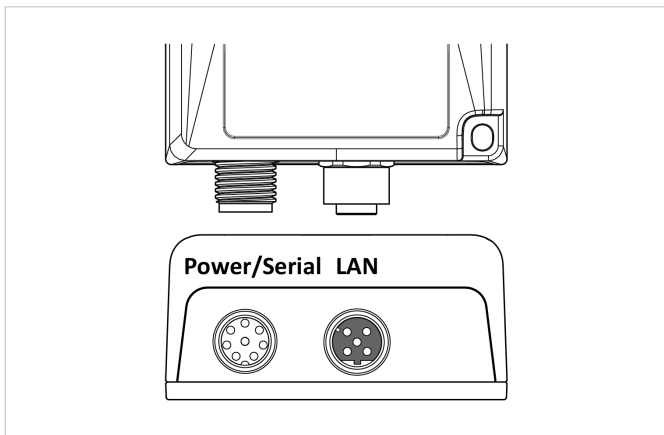

1. Connect the Bridge II Serial to LAN network.

Table 1. LAN connector pinout

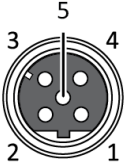
LAN Connector	Pin	Function
	1	Transmit +
	2	Receive +
	3	Transmit -
	4	Receive -
	5	N/C

2. Connect the Bridge II Serial a serial network and Power.

Table 2. Shielded 8-pos A-coded M12 female connector

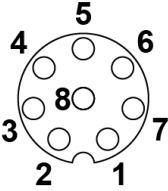
Serial and Power Connector	Pin	Wire Color		Function
	1	WH (White)	BU (Blue)	RS-232 TX
	2	WH (White)	BN (Brown)	Power 24 V
	3	BN (Brown)		Power GND
	4	OG (Orange)		RS-422_TX_A, RS485_A
	5	WH (White)	GN (Green)	RS-422_RX_B
	6	WH (White)	OG (Orange)	RS-422_TX_B, RS485_B
	7	BU (Blue)		Signal GND
	8	GN (Green)		RS-422_RX_A, RS-232_RX
	Housing	N/A		Acts as product FE (Functional Earth) when the cable shield is connected to FE.

5. Configuration

5.1. Required IP Address Settings

To be able to access the Bridge II Serial built-in web interface you may need to adjust the IP settings, choose one of the following methods.

The Bridge II Serial default IP address is 192.168.0.99.

Option 1 - Set a Static IP Address on Your PC



On the PC accessing the Bridge II Serial built-in web interface, set a static IP address within the same IP address range as the Bridge II Serial IP address.

To access the Bridge II Serial built-in web interface, ensure that Port 80 TCP is open in your PC Windows Firewall.

Note that when you change to a static IP address on your PC, internet access is lost.

Option 2 - Change the IP Address on the Bridge II Serial Ethernet port

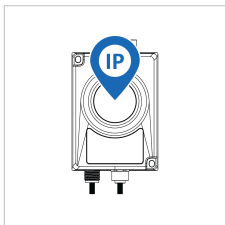

Use the software application HMS IPconfig to find and change the IP address on the Bridge II Serial Ethernet port, to one within the same IP address range as the PC accessing the Bridge II Serial built-in web interface.

To download the installation files, please visit www.anybus.com/support and enter the product article number to search for the Bridge II Serial support web page. You find the product article number on the product cover.

Result

Now you can enter the Bridge II Serial IP address in your web browser and search to access the built-in web interface login page.

5.2. Bridge II Serial Built-In Web Interface

The Bridge II Serial built-in web interface is used to configure, maintain and troubleshoot the Bridge II Serial. Parameters can be set individually or using pre-configured Easy Config modes.

The web interface is accessed by pointing a web browser to the IP address of the unit.

The default address is 192.168.0.99.

See also [Required IP Address Settings \(page 14\)](#).

The configuration settings are described in detail in the User Manual.

The screenshot displays the 'System Overview' page of the Bridge II Serial web interface. On the left is a navigation menu with the following items: System Overview (highlighted), Easy Config, Network Settings, WLAN Settings, Bluetooth Settings, Bluetooth LE Settings, Firmware Update, AT Commands, System Settings, Help, 'Save and Reboot', and 'Cancel All Changes'. The main content area is divided into three sections: IP, LAN, and WLAN.

IP	
IP Assignment	Static
IP Address	192.168.0.99
Subnet Mask	255.255.255.0
Default Gateway	192.168.0.99
Internal DHCP Server	Disabled

LAN	
Connection	Connected
MAC Address	00-30-11-19-43-2C

WLAN	
Status	On
Operating Mode	Client
Connection	Connected
MIMO	Enabled
World Mode (1-11,36-140)	Enabled
Channel	Auto
Channel Bands	2.4 GHz & 5 GHz

Figure 6. System Overview page example

5.3. Configuration Methods

There are different methods available for configuring the Bridge II Serial.

Built-In Web Interface Settings

Bridge II Serial can be configured via the settings in the built-in web interface.

Easy Config Modes

Bridge II Serial can be configured using one of the pre-configured Easy Config modes.

AT Commands

Advanced configuration can be carried out by issuing AT (modem) commands through the web interface or over a Telnet or RAW TCP connection to port 8080.

For more information about how to use the AT commands, navigate to the built-in web interface **Help** page or see the AT Commands Reference Guide.

5.4. Easy Config Using the MODE Button

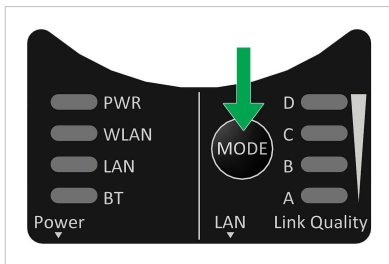

Figure 7. Easy Config Using the MODE Button

1. Power on the unit and wait for the **Link Quality** LEDs to light up and go out again, then immediately press and release the **MODE** button.
2. Press **MODE** repeatedly to cycle through the Easy Config modes until the desired mode is indicated by the **A-B-C-D** LEDs.
3. Within 20 seconds of step 2, press and hold **MODE** for 2 seconds. When the button is released the unit will restart in the selected mode.

See also [Available Easy Config Modes \(page 19\)](#).

5.5. Available Easy Config Modes

Bridge II Serial may be configured using one of the pre-configured Easy Config modes.



NOTE

By default, the unit starts in **Easy Config Mode 4**. The unit awaits automatic configuration during 120 seconds or until receiving a configuration.



NOTE

To cancel Easy Config mode 11, the unit must be reset to factory default settings. See [Reset to Factory Default \(page 20\)](#)

Table 3. Easy Config modes

EC	Active LED	Role	Description
1	A	Bluetooth PANU	Used for setting up point-to-point communication. The unit scans for another unit in Config Mode 4. The unit listens for 40 seconds or until a configuration is established. When a unit in mode 4 is detected: The scanning unit configures itself as a Bluetooth PANU Client, sends a connection configuration to the detected unit, and restarts. The detected unit restarts and attempt to connect to the first unit as a PANU Client.
2	B	N/A	Reset configuration to factory defaults.
3	A B	N/A	Reset IP settings to factory defaults.
4	C	Client	Configure units in mode 4 as Clients. Wait for automatic configuration. The unit listens for 120 seconds or until receiving a configuration. When mode 4 is used with mode 1, 5 or 6, Serial Settings TCP Mode Client is activated automatically.
5	A C	WLAN AP	The unit scans for other units in Config Mode 4 and configure them as Clients. Timeout occur after 120 seconds.
6	B C	Bluetooth NAP	Restart as Access Point and connect Clients.
11	A B D	(any)	Enable PROFIsafe mode. The unit is locked in PROFIsafe mode. No other configuration settings are changed.

5.6. Reset to Factory Default

Any one of these actions will restore the factory default settings:

- On the **System Settings** page, click **Factory Restore**.
- Execute **Easy Config Mode 2**.
- Issue the AT command **AT&F** and then restarting the unit.
- Press and hold **MODE** during >10 seconds, then releasing it.

5.7. Recovery Mode

If the built-in web interface cannot be accessed, the unit can be reset by starting in Recovery Mode and reinstalling the firmware.

Before You Begin



IMPORTANT

Use Recovery Mode only when the unit is unresponsive and the built-in web interface cannot be accessed. Firmware updates should normally be carried out through the built-in web interface.

Procedure

To enter Recovery Mode

1. Press and hold **MODE** button during startup.

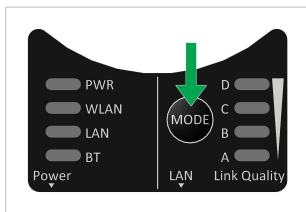

Figure 8. **MODE** button

2. Bridge II Serial enters Recovery Mode.

Table 4. In Recovery Mode the Status LEDs indicate the firmware update status

LED	Indication	Description
PWR	Green	Firmware update in progress
	Green, blinking	Waiting for valid firmware
WLAN + BT	Alternating red/blue	Firmware update in progress

To Reinstalling the Firmware

1. To reinstalling the firmware, you need Anybus Firmware Manager II.
Download Anybus Firmware Manager II from www.anybus.com/support.
2. Install Anybus Firmware Manager II on your PC.
3. Launch Anybus Firmware Manager II and follow the instructions to reinstall the firmware.

6. Factory Default Settings

The Bridge II Serial comes with the following factory default settings.

Default Network Settings	
IP Assignment	Static
IP Address	192.168.0.99
Subnet Mask	255.255.255.0
Default Gateway	192.168.0.99
Internal DHCP Server	Disabled
DHCP Interfaces	All

Default WLAN Settings	
Operating Mode	Client
Channel Bands	2.4 GHz & 5 GHz
Authentication Mode	WPA/WPA2-PSK
Channel	Auto
Bridge Mode	Layer 3 IP forward

Default Bluetooth Settings	
Operating Mode	PANU (Client)
Local Name	[generated from MAC address]
Connectable	No
Discoverable	No
Security Mode	Just works
Bluetooth LE	Operating Mode: Disabled Connectable: No Discoverable: No

Default Serial Settings	
Operating Mode	RS232

Default Serial Settings	
Baud Rate	57600 bits/s
Data Bits	8
Stop Bits	1
Parity	No parity
Modbus Optimization	Off
TCP Mode	Server
Modbus Gateway Mode	Disabled
TCP Port	5005

7. LED Indicators

Status Indicators

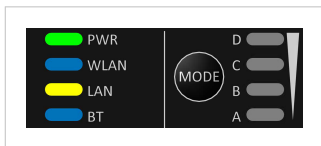

Figure 9. Status LED indicators

LED Indication		Description
PWR	Off	No power
	Green	Normal operation
WLAN	Off	WLAN disabled or no power
	Blue, blinking	Access Point: No clients, awaiting connections
	Blue	Access Point: Connected to at least one Client Client: Connected to Access Point
	Blue, flickering	WLAN data activity (when connected)
	Purple, blinking	Client: Scanning for access points
	Purple	Client: Connecting to a detected Access Point
	Red	Unrecoverable error
LAN	Off	No Ethernet connection
	Yellow	Ethernet link present
	Yellow, flickering	Ethernet data activity (when connected)
BT	Off	Bluetooth disabled or no power
	Blue, blinking	NAP: No clients, awaiting connections
	Blue	NAP: Connected to at least one PANU Client PANU: Connected to NAP
	Blue, flickering	Bluetooth data activity (when connected)
	Purple	PANU: Trying to connect to NAP
	Red	Unrecoverable error

Link Quality/Mode Indicators

The Link Quality/Mode Indicators are used to indicate Bluetooth quality, selected Easy Config mode and update status in Recovery Mode.

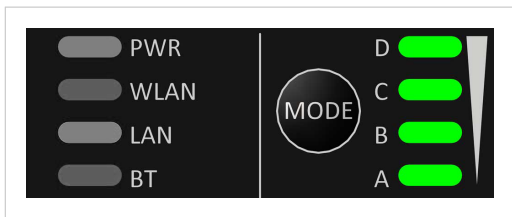

Figure 10. Link Quality/Mode indicators

Table 5. RSSI (WLAN Client) / Link Quality (Bluetooth PANU)

LED				Description
LED is off	LED is off	LED is off	LED is off	No connection
A, Green	LED is off	LED is off	LED is off	RSSI/Link Quality < 25 %
A, Green	B, Green	LED is off	LED is off	RSSI/Link Quality 25–50 %
A, Green	B, Green	C, Green	LED is off	RSSI/Link Quality 50–75 %
A, Green	B, Green	C, Green	D, Green	RSSI/Link Quality > 75 %

Recovery Mode LED Indications

Table 6. In Recovery Mode the Status LEDs indicate the firmware update status

LED	Indication	Description
PWR	Green	Firmware update in progress
	Green, blinking	Waiting for valid firmware
WLAN + BT	Alternating red/blue	Firmware update in progress

8. Technical Specifications

Order Code	AWB3005	AWB3015
Serial interface	Serial: RS232/RS422/RS485 Baud rate: 2400 - 921600 bit/s Data bits 5-8, stop bits 1-2, parity None, Odd, Even. Transparent serial protocol transfer including support for Modbus-RTU and Modbus-TCP to Modbus-RTU transparent routing.	
Ethernet interface	Ethernet: 10/100BASE-T with automatic MDI/MDIX auto cross-over detection. For configuration only.	
WiFi interface	Wireless standards: IEEE 802.11 a, b, g, n, d. Operation modes: Access Point or Client Wireless LAN bands: 2.4 GHz and 5 GHz RF output power: 18 dBm EIRP (including antenna gain 3 dBi) Max number of Clients for Access Point: 7 Power consumption: 54mA@24VDC Net data throughput: 20 Mbps. Link speed: max 65 Mbps (802.11n SISO) Security: WEP 64/128, WPA, WPA-PSK and WPA2, TKIP and AES/CCMP, LEAP, PEAP including MS-CHAP.	
Bluetooth interface	Wireless standards (profiles): PANU & NAP Operation modes: Access Point or Client RF output power: 14 dBm EIRP (including antenna gain 3 dBi) Bluetooth conducted sensitivity: -90 dBm Max number of slaves for Access Point: 7 Power consumption: 36 mA@24VDC Net data throughput: ~1 Mbps Bluetooth version support: Classic Bluetooth v2.1 Security: Authentication & Authorization, Encryption & Data Protection, Privacy & Confidentiality, NIST Compliant, FIPS Approved	
Dimensions	93 x 68 x 33 mm (H•W•D)	
Weight	120 g or 0,26 lbs	
Temperature	Operating: -30 to +65 °C (-22 to +149 °F) Storage: -40 to +85 °C (-40 to +185°F)	
Output power	WiFi 18 dBm EIRP - Bluetooth 14 dBm EIRP - Bluetooth Low Energy 10 dBm EIRP All including antenna gain 3dBi	
Power supply	9-30 VDC (-5% +20%), Cranking 12 V (ISO 7637-2:2011 pulse 4). Reverse polarity protection.	

Order Code	AWB3005	AWB3015
Power consumption	0.7 W idle, 1.7 W max (54mA@24VDC with Wireless LAN and 36mA@24VDC with Bluetooth)	
Enclosure material	Plastic PC/ABS (Bayblend FR3010)	
Mechanical rating	IP65	
Mounting	Two screws (Ø 4 mm) on flat surface. DIN rail mount option available (optional accessory).	
Max range	400 meters	
Antennas	Three internal antennas: 1. 2.4 GHz 2. 2,4 GHz MIMO 3. 5 GHz	One external antenna: 1. 2,4/5 GHz dual band
	The external antenna does not provide better range but allows connectivity if the Wireless Bridge needs to be placed inside a radio-secure environment such as a steel cabinet. When mounting inside a steel cabinet antenna cables with magnetic foot or screw mount should also be considered.	
Connectors	1x M12 for Ethernet (4-pin, D-coded) 1x M12 for Power + Serial 5-pin, A-coded	1x M12 for Ethernet (4-pin, D-coded) 1x M12 for Power + Serial 5-pin, A-coded RP-SMA antenna connector for external antenna variant
Vibration compatibility	Sinusoidal vibration test according to IEC 60068-2-6:2007 and with extra severities; Number of axes: 3 mutually perpendicular (X:Y:Z), Duration: 10 sweep cycles in each axis, Velocity: 1 oct/min, Mode: in operation, Frequency: 5-500 Hz. 5-8,4Hz=±3.5mm; 8,4-40,7Hz=1g; 40,7-57Hz=±0,15mm;57-500Hz=2g. Shock test according to IEC 60068-2-27:2008 and with extra severities; Wave shape: half sine, Number of shocks: ±3 in each axis, Mode: In operation, Axes ± X,Y,Z, Acceleration: 30 m/s ² , Duration: 11 ms.	

Region	Certifications
Europe	CE, 2014/53/EU Radio Equipment Directive (RED)
USA	FCC 47 CFR part 15, subpart B. UL: Ind. Cont. Eq. UL file: E214107
Canada	ICES-003
Japan	MIC

For complete technical specifications and regulatory compliance information, please visit www.anybus.com/support.