

# INVERTER

## FR-E800

### INSTALLATION GUIDELINE

**FR-E820-0008(0.1K) to 0900(22K)**

**FR-E840-0016(0.4K) to 0440(22K)**

**FR-E820S-0008(0.1K) to 0110(2.2K)**

**FR-E820-0008(0.1K)E to 0900(22K)E**

**FR-E840-0016(0.4K)E to 0440(22K)E**

**FR-E820S-0008(0.1K)E to 0110(2.2K)E**

**FR-E820-0008(0.1K)SCE to 0900(22K)SCE**

**FR-E840-0016(0.4K)SCE to 0440(22K)SCE**

**FR-E820S-0008(0.1K)SCE to 0110(2.2K)SCE**

Thank you for choosing this Mitsubishi Electric Inverter.  
 This Installation guideline and the enclosed CD-ROM give handling information and precautions for use of this product.  
 Do not use this product until you have a full knowledge of the equipment, the safety information and the instructions.  
 Please forward this Installation guideline to the end user.

#### CONTENTS

|          |  |           |
|----------|--|-----------|
| <b>1</b> | <b>INSTALLATION AND INSTRUCTIONS.....</b>                  | <b>1</b>  |
| <b>2</b> | <b>WIRING .....</b>  | <b>5</b>  |
| <b>3</b> | <b>FAILSAFE OF THE SYSTEM WHICH USES THE INVERTER.....</b> | <b>31</b> |
| <b>4</b> | <b>PRECAUTIONS FOR USE OF THE INVERTER .....</b>           | <b>29</b> |
| <b>5</b> | <b>BASIC OPERATION .....</b>                               | <b>35</b> |
| <b>6</b> | <b>PARAMETER LIST .....</b>                                | <b>41</b> |
| <b>7</b> | <b>INVERTER FAULT AND ALARM INDICATIONS.....</b>           | <b>55</b> |
| <b>8</b> | <b>SPECIFICATIONS .....</b>                                | <b>59</b> |
| <b>A</b> | <b>APPENDIX .....</b>                                      | <b>65</b> |



Version check

Art. no.: 574333  
 25082021  
 Version B

| Print Date        | Art. no. | Revision  |
|-------------------|----------|---|
| 07/2020 pdp - tri | 574333-A | First edition   |
| 08/2021 pdp - gbr | 574333-B | Additions: <ul style="list-style-type: none"> <li>•FR-E820-0470(11K) to 0900(22K)(E)(SCE)</li> <li>•FR-E840-0230(11K) to 0440(22K)(E)(SCE)</li> <li>•Parameters</li> </ul> Changes:      Parameter setting values |
|                   |          |   |

 **For Maximum Safety**

- Mitsubishi Electric transistorized inverters are not designed or manufactured to be used in equipment or systems in situations that can affect or endanger human life.
- When considering this product for operation in special applications such as machinery or systems used in passenger transportation, medical, aerospace, atomic power, electric power, or submarine repeating applications, please contact your nearest Mitsubishi Electric sales representative.
- Although this product was manufactured under conditions of strict quality control, you are strongly advised to install safety devices to prevent serious accidents when it is used in facilities where breakdowns of the product are likely to cause a serious accident.
- Please check upon receiving of the inverter whether this instruction manual corresponds to the delivered inverter. Compare the specifications on the capacity plate with the specifications given in this manual.

### This section is specifically about safety matters

Do not attempt to install, operate, maintain or inspect the inverter until you have read through this Installation Guideline and appended documents carefully and can use the equipment correctly. Do not use the inverter until you have a full knowledge of the equipment, safety information and instructions.

Installation, operation, maintenance and inspection must be performed by qualified personnel. Here, qualified personnel means personnel who meets all the conditions below.

- A person who took a proper engineering training. Please note if you can take a proper engineering training at your local Mitsubishi Electric office. Such training may be available at your local Mitsubishi Electric office. Contact your local sales office for schedules and locations.
- A person who can access operating manuals for the protective devices (e.g. light curtain) connected to the safety control system.

A person who has read and familiarized himself/herself with the manuals.

In this Installation Guideline, the safety instruction levels are classified into "WARNING" and "CAUTION".

#### **WARNING**

Assumes that incorrect handling may cause hazardous conditions, resulting in death or severe injury.

#### **CAUTION**

Assumes that incorrect handling may cause hazardous conditions, resulting in medium or slight injury, or may cause physical damage only.

Note that even the  **CAUTION** level may lead to a serious consequence according to conditions. Please follow strictly the instructions of both levels because they are important to personnel safety.

### Electric Shock Prevention

#### **WARNING**

- While power is on or when the inverter is running, do not open the front cover. Otherwise you may get an electric shock.
- Do not run the inverter with the front cover removed. Otherwise, you may access the exposed high-voltage terminals or the charging part of the circuitry and get an electric shock.
- Even if power is off, do not remove the front cover except for wiring or periodic inspection. You may access the charged inverter circuits and get an electric shock.
- Before starting wiring or inspection, check to make sure that the LED display of the operation panel is off, wait for at least 10 minutes after the power supply has been switched off, and check that there are no residual voltage using a tester or the like. The capacitor is charged with high voltage for some time after power off and it is dangerous.
- This inverter must be earthed. Earthing must conform to the requirements of national and local safety regulations and electrical codes (JIS, NEC section 250, IEC 536 class 1 and other applicable standards). A neutral-point earthed power supply for 400V class inverter in compliance with EN standard must be used.
- Any person who is involved in the wiring or inspection of this equipment should be fully competent to do the work.
- Always install the inverter before wiring. Otherwise, you may get an electric shock or be injured.
- If your application requires by installation standards an RCD (residual current device) as up stream protection please select according to DIN VDE 0100-530 as following:
  - Single phase inverter type A or B
  - Three phase inverter only type B(Additional instructions on the use of a residual current device are contained on *page 66*.)
- Perform setting dial and key operations with dry hands to prevent an electric shock. Otherwise you may get an electric shock.
- Do not subject the cables to scratches, excessive stress, heavy loads or pinching. Otherwise you may get an electric shock.
- Do not replace the cooling fan while power is on. It is dangerous to replace the cooling fan while power is on.
- Do not touch the printed circuit board or handle the cables with wet hands. You may get an electric shock.
- When measuring the main circuit capacitor capacity, the DC voltage is applied to the motor for 1s at powering OFF. Never touch the motor terminal, etc. right after powering OFF to prevent an electric shock.
- A PM motor is a synchronous motor with high-performance magnets embedded in the rotor. Motor terminals holds high-voltage while the motor is running even after the inverter power is turned OFF. Before wiring or inspection, the motor must be confirmed to be stopped. In an application, such as fan and blower, where the motor is driven by the load, a low-voltage manual motor starter must be connected at the inverter's output side, and wiring and inspection must be performed while the motor starter is open. Otherwise you may get an electric shock.

### Fire Prevention

#### **CAUTION**

- Mount the inverter to incombustible material. Install the inverter on a nonflammable wall without holes (so that nobody can touch the inverter heatsink on the rear side, etc.). Mounting it to or near combustible material can cause a fire.
- If the inverter has become faulty, switch off the inverter power. A continuous flow of large current could cause a fire.
- Do not connect a resistor directly to the DC terminals P/+, N/-. This could cause a fire and destroy the inverter.
- The surface temperature of braking resistors can far exceed 100°C for brief periods. Make sure that there is adequate protection against accidental contact and a safe distance is maintained to other units and system parts.
- Be sure to perform daily and periodic inspections as specified in the Instruction Manual. If a product is used without any inspection, a burst, breakage, or a fire may occur.

## Injury Prevention

### ⚠CAUTION

- Apply only the voltage specified in the instruction manual to each terminal. Otherwise, burst, damage, etc. may occur.
- Ensure that the cables are connected to the correct terminals. Otherwise, burst, damage, etc. may occur.
- Always make sure that polarity is correct to prevent damage, etc. Otherwise, burst, damage, etc. may occur.
- While power is on or for some time after power-off, do not touch the inverter as it is hot and you may get burnt.

## Additional Instructions

The following instructions must be also followed. If the product is handled incorrectly, it may cause unexpected fault, an injury, or an electric shock.

## Transportation and installation

### ⚠CAUTION

- Any person who is opening a package using a sharp object, such as a knife and cutter, must wear gloves to prevent injuries caused by the edge of the sharp object.
- When carrying products, use correct lifting gear to prevent injury.
- Do not stand or rest heavy objects on the product.
- Do not stack the inverter boxes higher than the number recommended.
- When carrying the inverter, do not hold it by the front cover or setting dial; it may fall off or fail.
- During installation, caution must be taken not to drop the inverter as doing so may cause injuries.
- Ensure that installation position and material can withstand the weight of the inverter. Install according to the information in the instruction manual.
- Do not install the product on a hot surface.
- Check the inverter mounting orientation is correct.
- The inverter must be installed on a strong surface securely with screws so that it will not drop.
- Do not install or operate the inverter if it is damaged or has parts missing. This can result in breakdowns.
- Prevent other conductive bodies such as screws and metal fragments or other flammable substance such as oil from entering the inverter.
- As the inverter is a precision instrument, do not drop or subject it to impact.
- Use the inverter under the following environmental conditions. Otherwise, the inverter may be damaged.

| Operating condition         | FR-E800   |
|-----------------------------|---|
| Surrounding air temperature | -20°C to +60°C (The rated current must be reduced at a temperature above 50°C.)   |
| Surrounding air humidity    | 95% RH or less (non-condensing) (With circuit board coating (conforming to IEC 60721-3-3 3C2))<br>90% RH or less (non-condensing) (Without circuit board coating) |
| Storage temperature         | -40°C to +70°C <sup>*1</sup>  |
| Atmosphere                  | Indoors (free from corrosive gas, flammable gas, oil mist, dust and dirt)   |
| Altitude/vibration          | Maximum 3000 m <sup>*2</sup> , 5.9 m/s <sup>2</sup> or less at 10 to 55 Hz in X, Y, and Z directions  |

<sup>\*1</sup> Applicable to conditions for a short time, for example, in transit.

<sup>\*2</sup> For the installation at an altitude above 1000 m, consider a 3% reduction in the rated current per 500 m increase in altitude.

- If halogen-based materials (fluorine, chlorine, bromine, iodine, etc.) infiltrate into a Mitsubishi Electric product, the product will be damaged. Halogen-based materials are often included in fumigant, which is used to sterilize or disinfect wooden packages. When packaging, prevent residual fumigant components from being infiltrated into Mitsubishi Electric products, or use an alternative sterilization or disinfection method (heat disinfection, etc.) for packaging. Sterilization or disinfection of wooden package should also be performed before packaging the product.
- To prevent a failure, do not use the inverter with a part or material containing halogen flame retardant including bromine.

## Wiring

### ⚠CAUTION

- Do not install assemblies or components (e. g. power factor correction capacitors) on the inverter output side, which are not approved from Mitsubishi Electric. These devices on the inverter output side may be overheated or burn out.
- The direction of rotation of the motor corresponds to the direction of rotation commands (STF/STR) only if the phase sequence (U, V, W) is maintained.
- PM motor terminals (U, V, W) hold high-voltage while the PM motor is running even after the power is turned OFF. Before wiring, the PM motor must be confirmed to be stopped. Otherwise you may get an electric shock.
- Never connect a PM motor to the commercial power supply.  
Applying the commercial power supply to input terminals (U,V, W) of a PM motor will burn the PM motor. The PM motor must be connected with the output terminals (U, V, W) of the inverter.

## Test operation and adjustment

### ⚠CAUTION

- Before starting operation, confirm and adjust the parameters. A failure to do so may cause some machines to make unexpected motions.

## Operation

### **WARNING**

- When you have chosen the retry function, stay away from the equipment as it will restart suddenly after an alarm stop.
- Since pressing the  key may not stop output depending on the function setting status, provide a circuit and switch separately to make an emergency stop (power off, mechanical brake operation for emergency stop, etc).
- Make sure that the start signal is off before resetting the inverter alarm. A failure to do so may restart the motor suddenly.
- Do not use a PM motor for an application where the PM motor is driven by its load and runs at a speed higher than the maximum motor speed.
- The inverter can be started and stopped via the serial port communications link or the field bus. However, please note that depending on the settings of the communications parameters it may not be possible to stop the system via these connections if there is an error in the communications system or the data line. In configurations like this it is thus essential to install additional safety hardware that makes it possible to stop the system in an emergency (e.g. controller inhibit via control signal, external motor contactor etc). Clear and unambiguous warnings about this must be posted on site for the operating and service staff.
- Use this inverter only with three-phase induction motors or with a PM motor. Connection of any other electrical equipment to the inverter output may damage the inverter as well as the equipment.
- Performing pre-excitation (LX signal and X13 signal) under torque control may start the motor running at a low speed even when the start signal (STF or STR) is not input. This product with the start command ON may also rotate the motor at a low speed when the speed limit value is set to zero. Confirm that the motor running does not cause any safety problems before performing pre-excitation.
- Do not modify the equipment.
- Do not perform parts removal which is not instructed in this manual. Doing so may lead to fault or damage of the inverter.

### **CAUTION**

- The electronic thermal relay function does not guarantee protection of the motor from overheating. It is recommended to install both an external thermal and PTC thermistor for overheat protection.
- Do not use a magnetic contactor on the inverter input for frequent starting/stopping of the inverter. Otherwise, the life of the inverter decreases.
- Use a noise filter to reduce the effect of electromagnetic interference and follow the accepted EMC procedures for proper installation of frequency inverters. Otherwise nearby electronic equipment may be affected.
- Take appropriate measures regarding harmonics. Otherwise this can endanger compensation systems or overload generators.
- When driving a 400V class motor by the inverter, the motor must be an insulation-enhanced motor or measures must be taken to suppress surge voltage. Surge voltage attributable to the wiring constants may occur at the motor terminals, deteriorating the insulation of the motor.
- Use a motor designed for inverter operation. (The stress for motor windings is bigger than in line power supply).
- When parameter clear or all clear is performed, set again the required parameters before starting operations. Each parameter returns to the initial value.
- The inverter can be easily set for high-speed operation. Before changing its setting, fully examine the performances of the motor and machine.
- The DC braking function of the frequency inverter is not designed to continuously hold a load. Use an electro-mechanical holding brake on the motor for this purpose.
- Before running an inverter which had been stored for a long period, always perform inspection and test operation.
- For prevention of damage due to static electricity, touch nearby metal before touching this product to eliminate static electricity from your body.
- Only one PM motor can be connected to an inverter.
- A PM motor must be used under PM motor control. When operating with PM motor control, a synchronous motor, induction motor or synchronous induction motor may only be used when it is a PM motor.
- Do not connect a PM motor under the induction motor control settings (initial settings). Do not use an induction motor under the PM motor control settings. It will cause a failure.
- In the system with a PM motor, the inverter power must be turned ON before closing the contacts of the contactor at the output side.
- When the emergency drive operation is performed, the operation is continued or the retry is repeated even when a fault occurs, which may damage or burn the inverter and motor. Before restarting the normal operation after using the emergency drive function, make sure that the inverter and motor have no fault.
- To maintain the security (confidentiality, integrity, and availability) of the inverter and the system against unauthorized access, DoS<sup>\*1</sup> attacks, computer viruses, and other cyberattacks from external devices via network, take appropriate measures such as firewalls, virtual private networks (VPNs), and antivirus solutions. We shall have no responsibility or liability for any problems involving inverter trouble and system trouble by DoS attacks, unauthorized access, computer viruses, and other cyberattacks.
- Depending on the network environment, the inverter may not operate as intended due to delays or disconnection in communication. Carefully consider the conditions and safety for the inverter on site.

<sup>\*1</sup> DoS: A denial-of-service (DoS) attack disrupts services by overloading systems or exploiting vulnerabilities, resulting in a denial-of-service (DoS) state.

## Emergency stop

### **CAUTION**

- Provide a safety backup such as an emergency brake which will prevent the machine and equipment from hazardous conditions if the inverter fails.
- When the breaker on the inverter primary side trips, check for the wiring fault (short circuit), damage to internal parts of the inverter, etc. Identify the cause of the trip, then remove the cause and power on the breaker.
- When the protective function is activated (i. e. the frequency inverter switches off with an error message), take the corresponding corrective action as described in the inverter manual, then reset the inverter, and resume operation.

**Maintenance, inspection and parts replacement**

**⚠ CAUTION**

- Do not carry out a megger (insulation resistance) test on the control circuit of the inverter. It will cause a failure.

**Disposing of the inverter**

**⚠ CAUTION**

- Treat as industrial waste.

**General instructions**

Many of the diagrams and drawings in instruction manuals show the inverter without a cover, or partially open. Never run the inverter in this status. Always replace the cover and follow instruction manuals when operating the inverter. For more details on the PM motor, refer to the Instruction Manual of the PM motor.

# 1 INSTALLATION AND INSTRUCTIONS

Unpack the product and check the rating plate and the capacity plate of the inverter to ensure that the model agrees with the order and the product is intact.

## 1.1 Inverter Type

FR-E8   0   -          

A      B            C            D            E            F

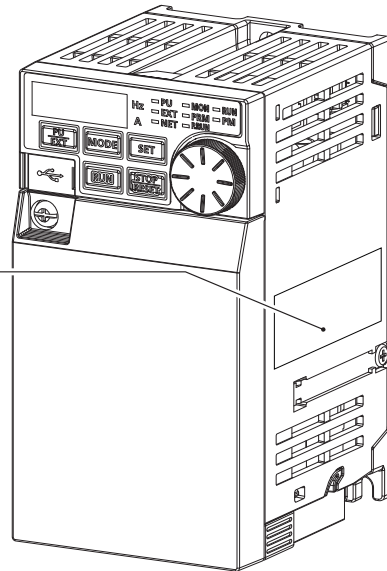
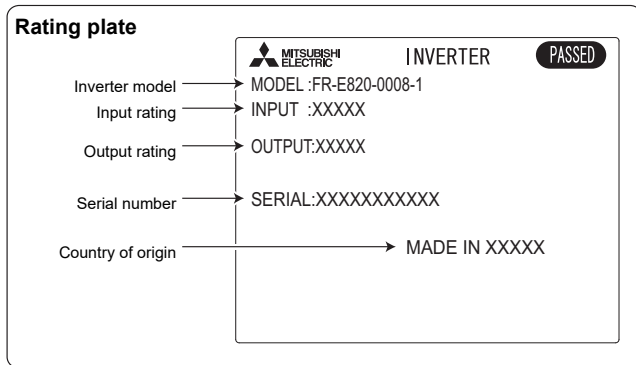

- A: The voltage class is shown.

| Symbol | Voltage class |
|--------|---------------|
| 2      | 200 V class   |
| 4      | 400 V class   |

- B: The number of phases of the power source is shown.

| Symbol | Description        |
|--------|--------------------|
| None   | Three-phase input  |
| S      | Single-phase input |

- C: The inverter rated capacity or the inverter rated current is shown.

| Symbol       | Description                     |
|--------------|---------------------------------|
| 0.1K to 22K  | Inverter ND rated capacity (kW) |
| 0008 to 0900 | Inverter ND rated current (A)   |

- D: The communication type and the functional safety specification are shown.

| Symbol | Communication / functional safety                |
|--------|--|
| None   | Standard model (RS-485 + SIL2/PLd)               |
| E      | Ethernet model (Ethernet + SIL2/PLd)             |
| SCE    | Safety communication model (Ethernet + SIL3/PLe) |



- E: The output specification for monitoring and the rated frequency are shown for the standard model and the communication protocol group is shown for the Ethernet model and the safety communication model. The control logic is fixed to the source logic for the safety communication model.

| Symbol | Monitoring/protocol specifications  | Rated frequency (initial setting) | Control logic                         |                      |
|--------|---|-----------------------------------|---------------------------------------|----------------------|
|        |   |                                   | Input signal (initial status)         | Safety stop signal   |
| -1     | Pulse (terminal FM)   | 60 Hz                             | Sink logic                            | Source logic (fixed) |
| -4     | Voltage (terminal AM)   | 50 Hz                             | Source logic                          |                      |
| -5     | Voltage (terminal AM)   | 60 Hz                             | Sink logic                            |                      |
| PA     | Protocol group A (CC-Link IE TSN, CC-Link IE Field Network Basic, MODBUS/TCP, EtherNet/IP, and BACnet/IP) | 60 Hz                             | Sink logic                            |                      |
| PB     | Protocol group B (CC-Link IE TSN, CC-Link IE Field Network Basic, MODBUS/TCP, PROFINET)                   | 50 Hz                             | Sink logic/Source logic <sup>*1</sup> |                      |

<sup>\*1</sup> The initial status of the control logic differs depending on the inverter model.  
Sink logic for the models indicated with the rated capacity (kW)  
Source logic for the models indicated with the rated current (A).

- F: Availability of circuit board coating / plated conductors is shown.

| Symbol            | Circuit board coating <sup>*1</sup> | Plated conductor          |
|-------------------|-------------------------------------|---------------------------|
| None              | Without coating                     | Without plated conductors |
| -60               | With coating                        | Without plated conductors |
| -06 <sup>*2</sup> | With coating                        | With plated conductors    |

<sup>\*1</sup> Conforming to IEC 60721-3-3 3C2

<sup>\*2</sup> Applicable for the FR-E820-0470(11K) or higher, and the FR-E840-0230(11K) or higher.

**CAUTION**

- In this Instruction Manual, the inverter model name consists of the inverter rated current and the applicable motor capacity. (Example) FR-E820-0008(0.1K)

## 1.2 Accessory

- Fan cover fixing screws

These screws are necessary for compliance with the EU Directives. For details, refer to the document enclosed with the product.

| Capacity  | Screw size (mm) | Quantity |
|---|-----------------|----------|
| FR-E820-0080(1.5K) to FR-E820-0330(7.5K),<br>FR-E840-0016(0.4K) to FR-E840-0170(7.5K),<br>FR-E820S-0080(1.5K) or higher | M3 × 35         | 1        |
| FR-E820-0470(11K), FR-E820-0600(15K),<br>FR-E840-0230(11K), FR-E840-0300(15K)   | M3 × 35         | 2        |
| FR-E820-0760(18.5K) or higher, FR-E840-0380(18.5K) or higher  | M3 × 50         | 2        |

## 1.3 How to read the SERIAL number

|  |  |
|--|--|
| <p><b>Rating plate example</b></p> <p> </p> <p>                 Symbol    Year    Month    Control number             </p> <p style="text-align: center;">SERIAL</p> | <p>The SERIAL consists of two symbols, three characters indicating the production year and month, and six characters indicating the control number.</p> <p>The last two digits of the production year are indicated as the Year, and the Month is indicated by 1 to 9, X (October), Y (November), or Z (December).</p> |
|--|--|

## 1.4 Installation of the inverter

### Inverter placement

FR-E820-0175(3.7K) or lower  
FR-E840-0016(0.4K) to 0170(7.5K)  
FR-E820S-0008(0.1K) to 0110(2.2K)

FR-E820-0240(5.5K) or higher  
FR-E840-0230(11K) or higher

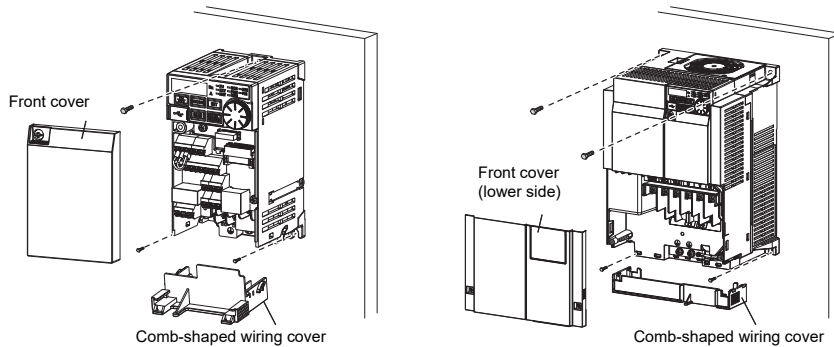

- Remove the front cover (or the lower front cover) and wiring cover to fix the inverter.
- Install the inverter on a strong surface securely with screws.
- Leave enough clearances and take cooling measures.
- Avoid places where the inverter is subjected to direct sunlight, high temperature and high humidity.
- Install the inverter on a nonflammable wall surface.
- When encasing multiple inverters in an enclosure, install them in parallel as a cooling measure.

### Installation orientation of the inverter

Install the inverter on a wall as specified. Do not mount it horizontally or in any other way.

#### • Above the inverter

Heat is blown up from inside the inverter by the small fan built in the unit. Any equipment placed above the inverter should be heat resistant.

#### • Arrangement of multiple inverters

When multiple inverters are placed in the same enclosure, generally arrange them horizontally as shown in the figure (a). When it is inevitable to arrange them vertically to minimize space, take such measures as to provide guides between the inverters since heat generated in the inverters in bottom row can increase the temperatures in the inverters in top row, causing inverter failures.

## 1.5 Environment

Before installation, check that the environment meets following specifications:

|                                    |  |  |
|------------------------------------|--|--|
| <b>Surrounding air temperature</b> | -20°C to +60°C (The rated current must be reduced at a temperature above 50°C.)  |  |
| <b>Ambient humidity</b>            | With circuit board coating (conforming to class 3C2 in IEC 60721-3-3): 95% RH or less (non-condensing)<br>Without circuit board coating: 90% RH or less (non-condensing) |  |
| <b>Storage temperature</b>         | -40°C to +70°C <sup>*1</sup>   |  |
| <b>Atmosphere</b>                  | Indoors (free from corrosive gas, flammable gas, oil mist, dust and dirt)  |  |
| <b>Altitude</b>                    | Maximum 3000 m <sup>*2</sup>   |  |
| <b>Vibration</b>                   | 5.9m/s <sup>2</sup> or less at 10 to 55 Hz (in either X, Y, or Z direction)  |  |

<sup>\*1</sup> Temperature applicable for a short time, for example, in transit.

<sup>\*2</sup> For installation at an altitude above 1000 m, consider a 3% reduction in the rated current per 500 m increase in altitude.



# 2 WIRING

## 2.1 Terminal connection diagrams

### 2.1.1 Standard model (sink logic)

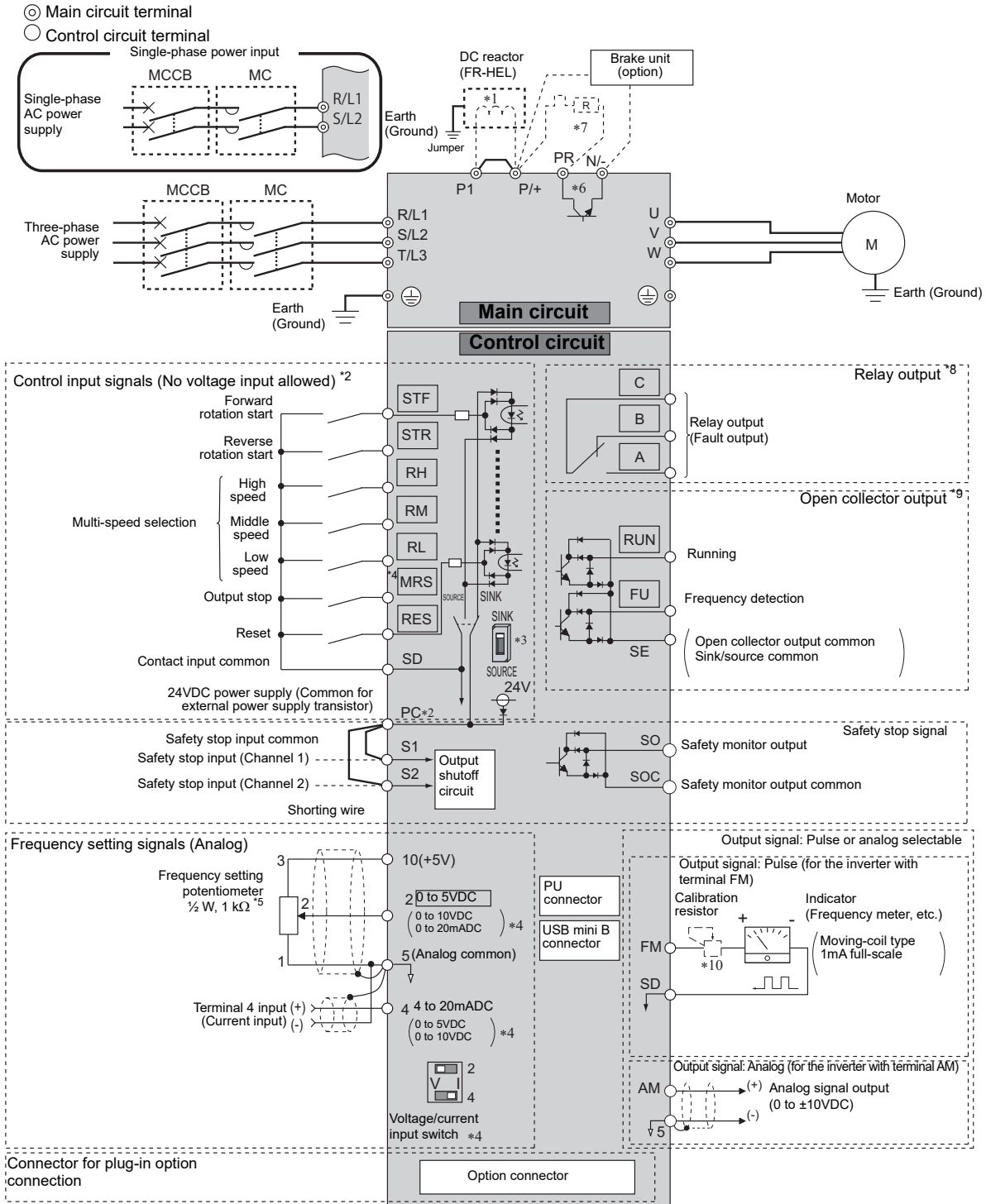

For footnotes \*1 to \*10 refer to next page.



- \*1 Remove the jumper between P1 and P/+ to connect the DC reactor.
- \*2 The function of these terminals can be changed using the Input terminal function selection (**Pr.178 to Pr.184**). (Refer to the FR-E800 Instruction Manual (Function).)
- \*3 The initial setting varies depending on the specification.
- \*4 Terminal input specifications can be changed by analog input specification switchover (**Pr.73, Pr.267**). To input voltage, set the voltage/current input selection switch to "V". To input current, set the switch to "I". The initial setting varies depending on the specification. (Refer to the FR-E800 Instruction Manual (Function).)
- \*5 It is recommended to use 2 W 1 k $\Omega$  when the frequency setting signal is changed frequently.
- \*6 The FR-E820-0008(0.1K), FR-E820-0015(0.2K), FR-E820S-0008(0.1K), and FR-E820S-0015(0.2K) are not equipped with brake transistors.
- \*7 Brake resistor (FR-ABR, MRS, MYS)  
Install a thermal relay to prevent overheating and damage of brake resistors. (A brake resistor cannot be connected to the FR-E820-0008(0.1K), FR-E820-0015(0.2K), FR-E820S-0008(0.1K), and FR-E820S-0015(0.2K).) (Refer to Instruction Manual (Connection)).
- \*8 The function of these terminals can be changed using the **Pr.192 ABC terminal function selection**.
- \*9 The function of these terminals can be changed using the Output terminal function selection (**Pr.190 or Pr.191**). (Refer to the FR-E800 Instruction Manual (Function).)
- \*10 Not required when calibrating the scale with the operation panel.

---

**CAUTION**

---

- To prevent a malfunction due to noise, keep the signal cables 10 cm or more away from the power cables. Also, keep the cables of the main circuit for input and output separated.
  - After wiring, wire offcuts must not be left in the inverter.  
Wire offcuts can cause a fault, failure or malfunction. Always keep the inverter clean.  
When drilling mounting holes in an enclosure etc., take caution not to allow chips and other foreign matter to enter the inverter.
  - Set the switches of the voltage/current input selection switch assembly correctly. Incorrect setting may cause a fault, failure or malfunction.
  - The output of the single-phase power input model is three-phase 200 V.
-

### 2.1.2 Standard model (source logic)

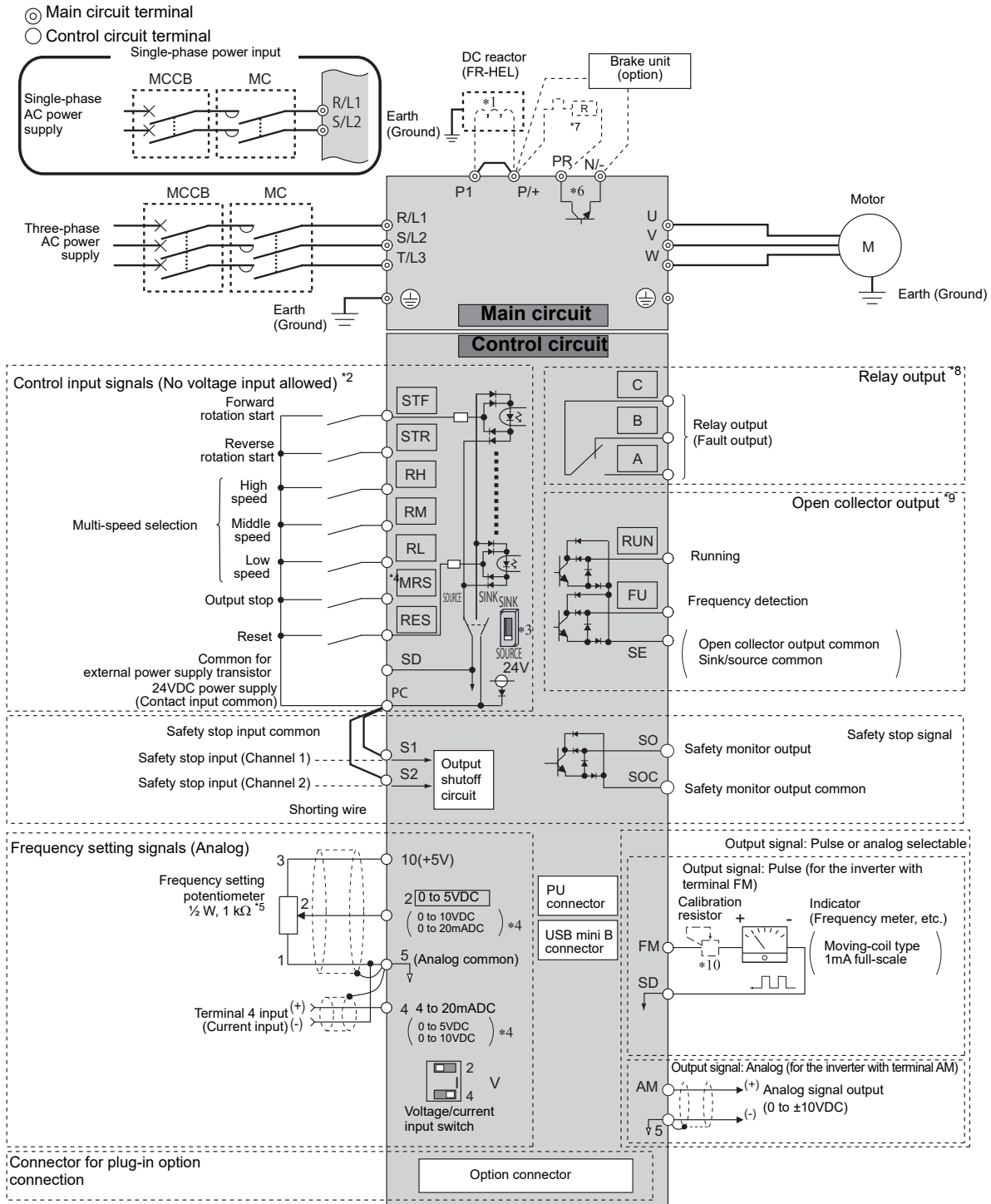

For footnotes \*1 to \*10 refer to next page.



- \*1 Remove the jumper between P1 and P/+ to connect the DC reactor.
- \*2 The function of these terminals can be changed using the Input terminal function selection (**Pr.178 to Pr.184**). (Refer to the FR-E800 Instruction Manual (Function).)
- \*3 The initial setting varies depending on the specification.
- \*4 Terminal input specifications can be changed by analog input specification switchover (**Pr.73, Pr.267**). To input voltage, set the voltage/current input selection switch to "V". To input current, set the switch to "I". The initial setting varies depending on the specification. (Refer to the FR-E800 Instruction Manual (Function).)
- \*5 It is recommended to use 2 W 1 k $\Omega$  when the frequency setting signal is changed frequently.
- \*6 The FR-E820-0008(0.1K), FR-E820-0015(0.2K), FR-E820S-0008(0.1K), and FR-E820S-0015(0.2K) are not equipped with brake transistors.
- \*7 Brake resistor (FR-ABR, MRS, MYS)  
Install a thermal relay to prevent overheating and damage of brake resistors. (A brake resistor cannot be connected to the FR-E820-0008(0.1K), FR-E820-0015(0.2K), FR-E820S-0008(0.1K), and FR-E820S-0015(0.2K).) (Refer to Instruction Manual (Connection)).
- \*8 The function of these terminals can be changed using the **Pr.192 ABC terminal function selection**.
- \*9 The function of these terminals can be changed using the Output terminal function selection (**Pr.190 or Pr.191**). (Refer to the FR-E800 Instruction Manual (Function).)
- \*10 Not required when calibrating the scale with the operation panel.

---

**CAUTION**

---

- To prevent a malfunction due to noise, keep the signal cables 10 cm or more away from the power cables. Also, keep the cables of the main circuit for input and output separated.
  - After wiring, wire offcuts must not be left in the inverter.  
Wire offcuts can cause a fault, failure or malfunction. Always keep the inverter clean.  
When drilling mounting holes in an enclosure etc., take caution not to allow chips and other foreign matter to enter the inverter.
  - Set the switches of the voltage/current input selection switch assembly correctly. Incorrect setting may cause a fault, failure or malfunction.
  - The output of the single-phase power input model is three-phase 200 V.
-

### 2.1.3 Ethernet mode (sink logic)

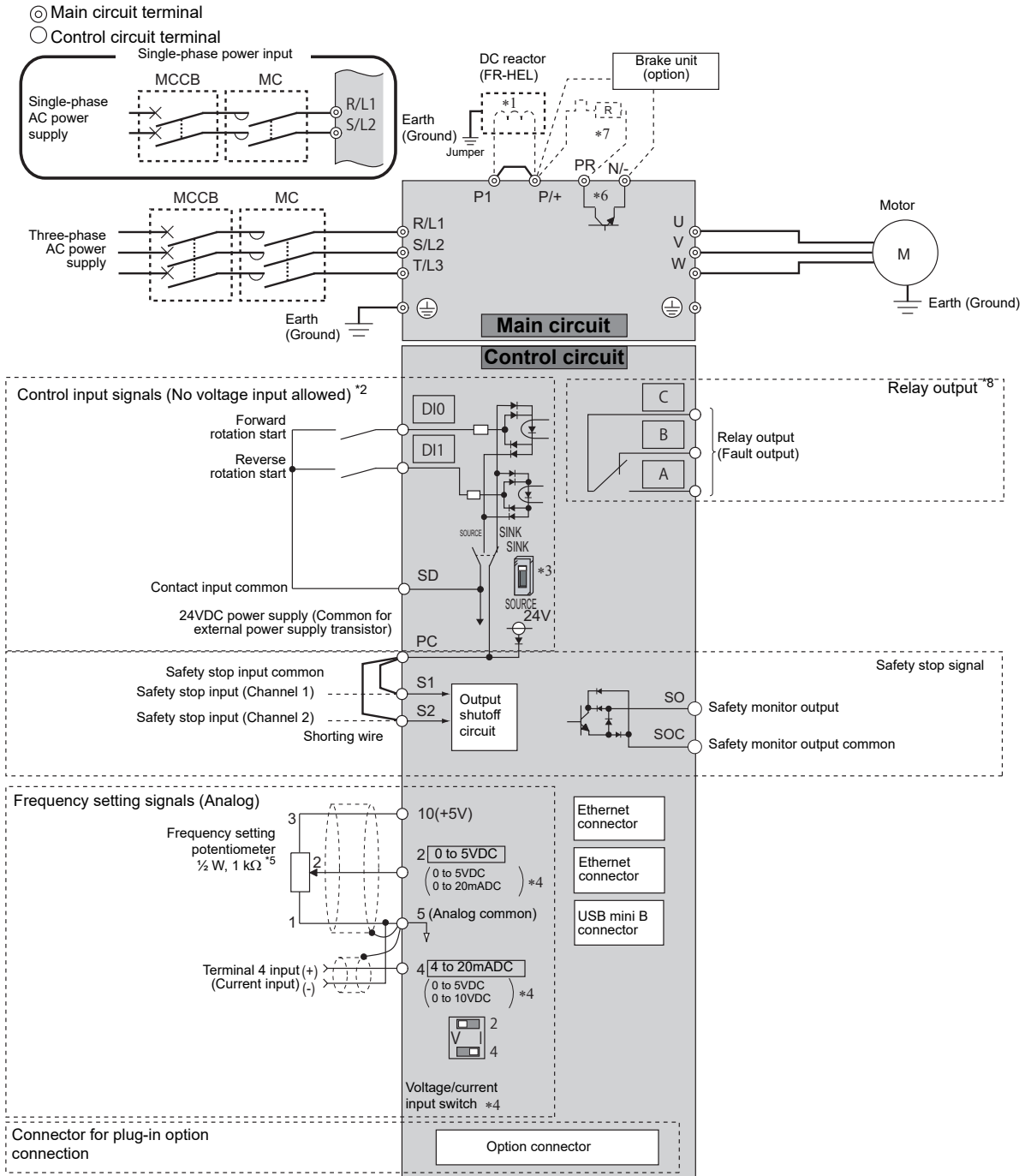

For footnotes \*1 to \*8 refer to next page.



- \*1 Remove the jumper between P1 and P/+ to connect the DC reactor.
- \*2 The function of these terminals can be changed using the Input terminal function selection (**Pr.178 to Pr.179**). (Refer to the FR-E800 Instruction Manual (Function).)
- \*3 The initial setting varies depending on the specification.
- \*4 Terminal input specifications can be changed by analog input specification switchover (**Pr.73, Pr.267**). To input voltage, set the voltage/current input selection switch to "V". To input current, set the switch to "I". The initial setting varies depending on the specification. (Refer to the FR-E800 Instruction Manual (Function).)
- \*5 It is recommended to use 2 W 1 k $\Omega$  when the frequency setting signal is changed frequently.
- \*6 The FR-E820-0008(0.1K), FR-E820-0015(0.2K), FR-E820S-0008(0.1K), and FR-E820S-0015(0.2K) are not equipped with brake transistors.
- \*7 Brake resistor (FR-ABR, MRS, MYS)  
Install a thermal relay to prevent overheating and damage of brake resistors. (A brake resistor cannot be connected to the FR-E820-0008(0.1K), FR-E820-0015(0.2K), FR-E820S-0008(0.1K), and FR-E820S-0015(0.2K).) (Refer to Instruction Manual (Connection))
- \*8 The function of these terminals can be changed using the **Pr.192 ABC terminal function selection**.

---

**CAUTION**

---

- To prevent a malfunction due to noise, keep the signal cables 10 cm or more away from the power cables. Also, keep the cables of the main circuit for input and output separated.
  - After wiring, wire offcuts must not be left in the inverter.  
Wire offcuts can cause a fault, failure or malfunction. Always keep the inverter clean.  
When drilling mounting holes in an enclosure etc., take caution not to allow chips and other foreign matter to enter the inverter.
  - Set the switches of the voltage/current input selection switch assembly correctly. Incorrect setting may cause a fault, failure or malfunction.
  - The output of the single-phase power input model is three-phase 200 V.
-

### 2.1.4 Ethernet mode (source logic)

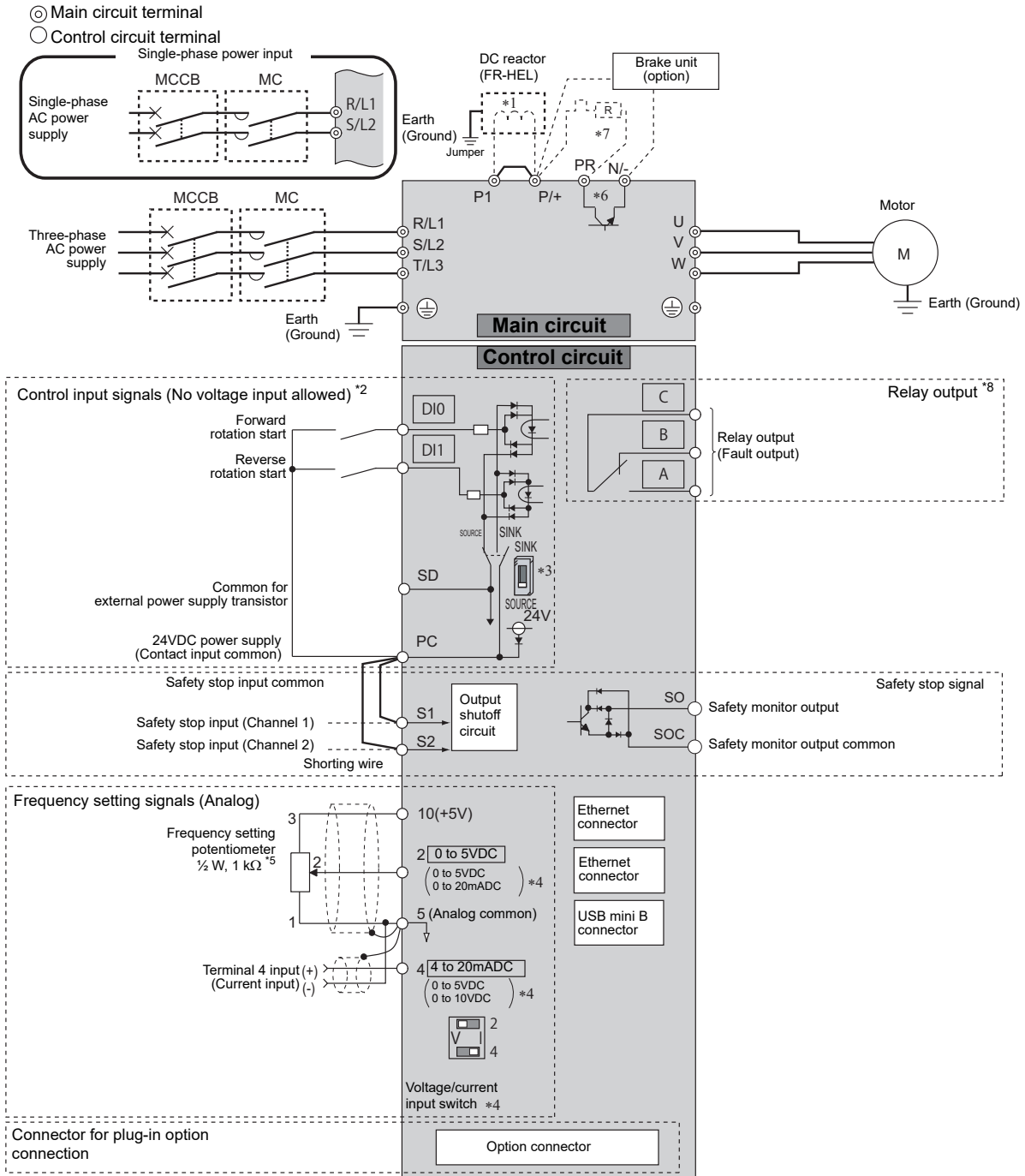

For footnotes \*1 to \*8 refer to next page.



- \*1 Remove the jumper between P1 and P/+ to connect the DC reactor.
- \*2 The function of these terminals can be changed using the Input terminal function selection (**Pr.178 to Pr.179**). (Refer to the FR-E800 Instruction Manual (Function).)
- \*3 The initial setting varies depending on the specification.
- \*4 Terminal input specifications can be changed by analog input specification switchover (**Pr.73, Pr.267**). To input voltage, set the voltage/current input selection switch to "V". To input current, set the switch to "I". The initial setting varies depending on the specification. (Refer to the FR-E800 Instruction Manual (Function).)
- \*5 It is recommended to use 2 W 1 k $\Omega$  when the frequency setting signal is changed frequently.
- \*6 The FR-E820-0008(0.1K), FR-E820-0015(0.2K), FR-E820S-0008(0.1K), and FR-E820S-0015(0.2K) are not equipped with brake transistors.
- \*7 Brake resistor (FR-ABR, MRS, MYS)  
Install a thermal relay to prevent overheating and damage of brake resistors. (A brake resistor cannot be connected to the FR-E820-0008(0.1K), FR-E820-0015(0.2K), FR-E820S-0008(0.1K), and FR-E820S-0015(0.2K).) (Refer to Instruction Manual (Connection))
- \*8 The function of these terminals can be changed using the **Pr.192 ABC terminal function selection**.

---

**CAUTION**

---

- To prevent a malfunction due to noise, keep the signal cables 10 cm or more away from the power cables. Also, keep the cables of the main circuit for input and output separated.
  - After wiring, wire offcuts must not be left in the inverter.  
Wire offcuts can cause a fault, failure or malfunction. Always keep the inverter clean.  
When drilling mounting holes in an enclosure etc., take caution not to allow chips and other foreign matter to enter the inverter.
  - Set the switches of the voltage/current input selection switch assembly correctly. Incorrect setting may cause a fault, failure or malfunction.
  - The output of the single-phase power input model is three-phase 200 V.
-

### 2.1.5 Safety communication model

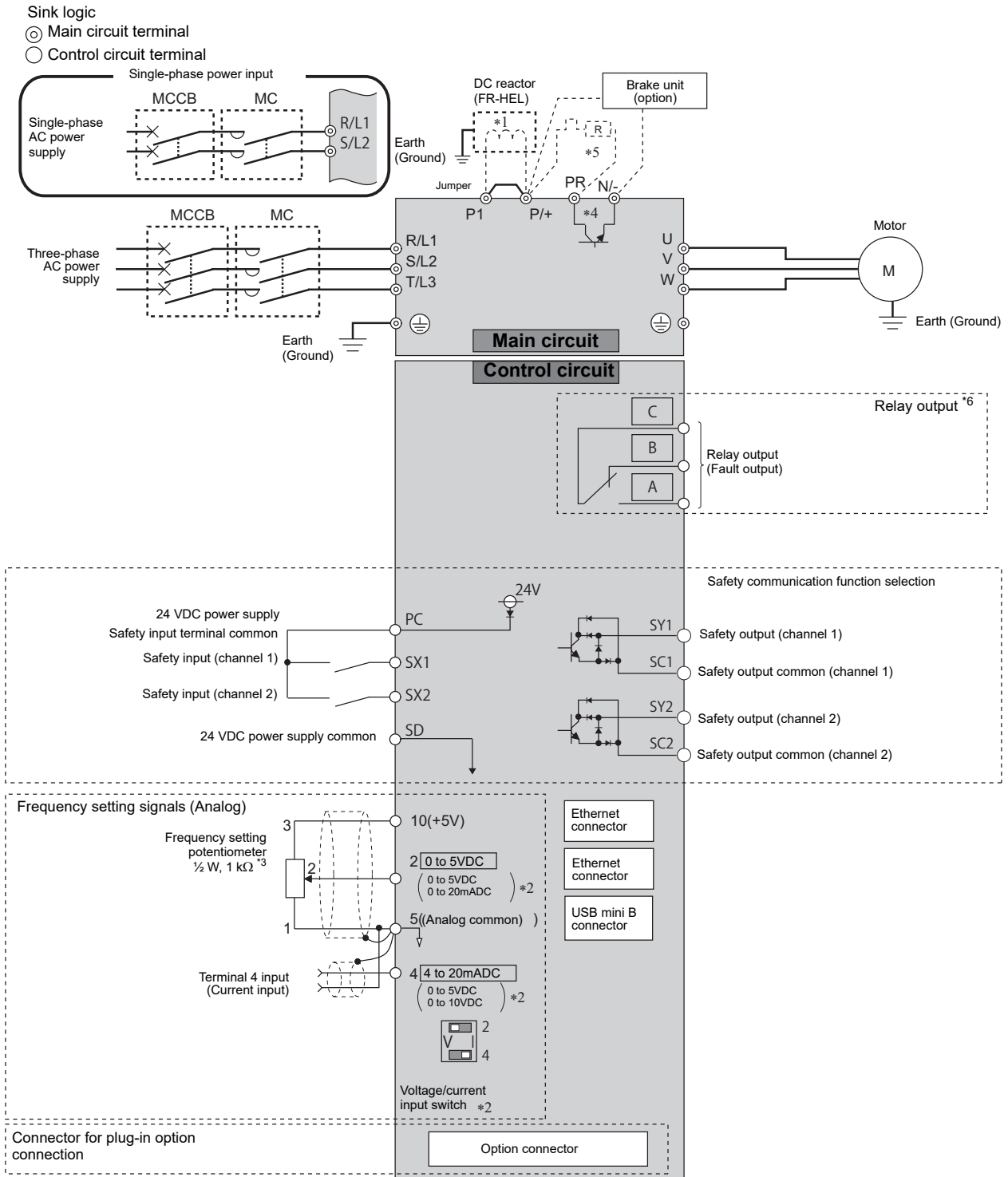

For footnotes \*1 to \*6 refer to next page.



- \*1 Remove the jumper between P1 and P/+ to connect the DC reactor.
- \*2 Terminal input specifications can be changed by analog input specification switchover (**Pr.73, Pr.267**). To input voltage, set the voltage/current input selection switch to "V". To input current, set the switch to "I". The initial setting varies depending on the specification. (Refer to the FR-E800 Instruction Manual (Function).)
- \*3 It is recommended to use 2 W 1 k $\Omega$  when the frequency setting signal is changed frequently.
- \*4 The FR-E820-0008(0.1K), FR-E820-0015(0.2K), FR-E820S-0008(0.1K), and FR-E820S-0015(0.2K) are not equipped with brake transistors.
- \*5 Brake resistor (FR-ABR, MRS, MYS)  
Install a thermal relay to prevent overheating and damage of brake resistors. (A brake resistor cannot be connected to the FR-E820-0008(0.1K), FR-E820-0015(0.2K), FR-E820S-0008(0.1K), and FR-E820S-0015(0.2K).) (Refer to Instruction Manual (Connection)).
- \*6 The function of these terminals can be changed using the **Pr.192 ABC terminal function selection**.

---

**CAUTION**

---

- To prevent a malfunction due to noise, keep the signal cables 10 cm or more away from the power cables. Also, keep the cables of the main circuit for input and output separated.
  - After wiring, wire offcuts must not be left in the inverter.  
Wire offcuts can cause a fault, failure or malfunction. Always keep the inverter clean.  
When drilling mounting holes in an enclosure etc., take caution not to allow chips and other foreign matter to enter the inverter.
  - Set the switches of the voltage/current input selection switch assembly correctly. Incorrect setting may cause a fault, failure or malfunction.
  - The output of the single-phase power input model is three-phase 200 V.
- 
-

## 2.2 Main circuit terminal

### 2.2.1 Terminal layout and wiring

- Three-phase 200/400 V class

FR-E820-0008(0.1K) to 0050(0.75K)

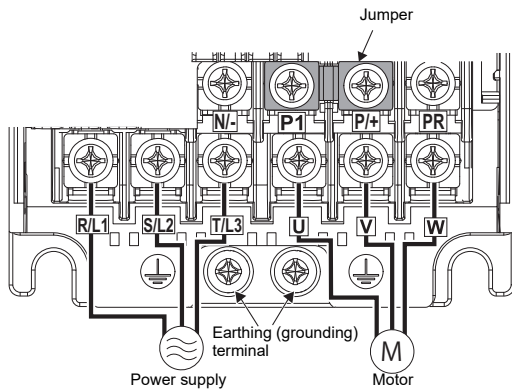

FR-E820-0080(1.5K) to 0175(3.7K)  
FR-E840-0016(0.4K) to 0095(3.7K)

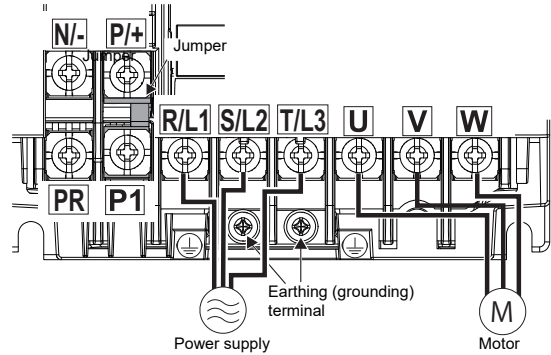

FR-E820-0240(5.5K), 0330(7.5K)

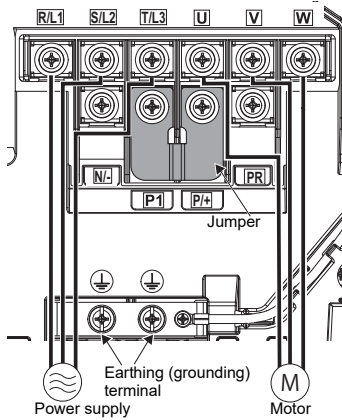

FR-E840-5.5K(0120), 7.5K(0170)

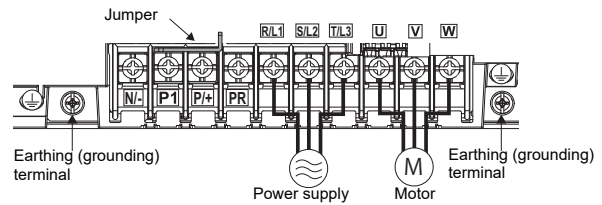

FR-E820-0470(11K), 0600(15K)

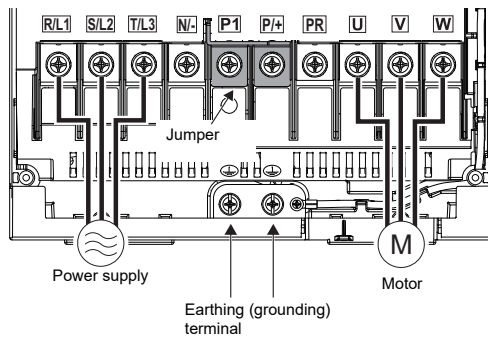

FR-E840-230(11K), 0300(15K)

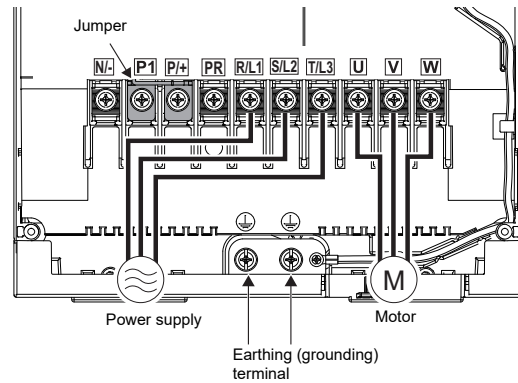

FR-E820-0760(18.5K), 0900(22K)  
FR-E840-0380(18.5K), 0440(22K)

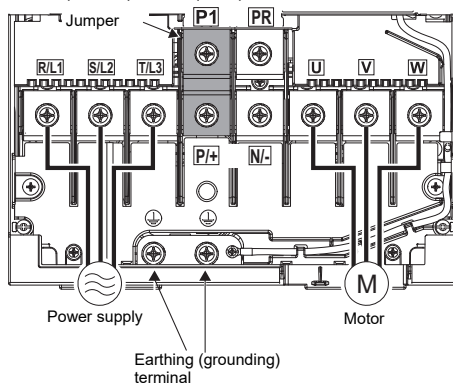



• Single-phase 200 V class

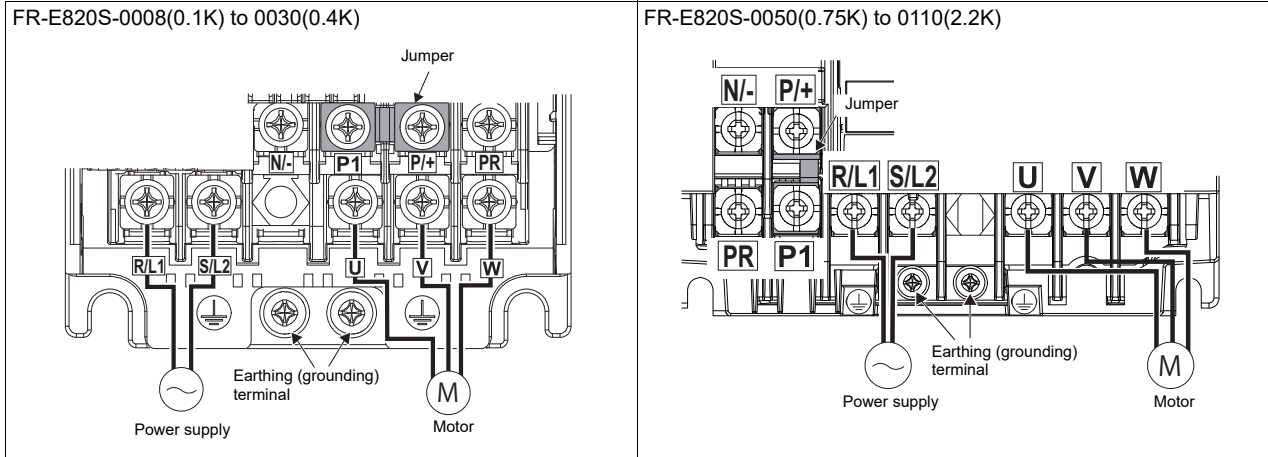

**CAUTION**

- The power supply cables must be connected to R/L1, S/L2, T/L3. Never connect the power cable to the U, V, W, of the inverter. Doing so will damage the inverter. (Phase sequence needs not to be matched.)
- Connect the motor to U, V, W. At this time turning on the forward rotation switch (signal) rotates the motor in the clockwise direction when viewed from the motor shaft. (The phase sequence must be matched.)

• Handling of the wiring cover

(FR-E820-0470(11K) to 0900(22K), FR-E840-0230(11K) to 0440(22K))

For the hook of the wiring cover, cut off the necessary parts using a pair of needle-nose pliers etc.

**CAUTION**

- Cut off the same number of lugs as wires. If parts where no wire is put through have been cut off (10 mm or more), protective structure (IEC 60529) becomes an open type (IP00).

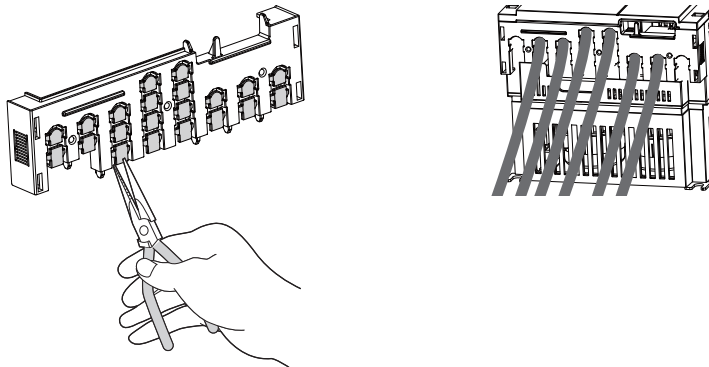

## 2.3 Wiring fundamentals

### 2.3.1 Applicable cables and wiring length

For the ND rating

- Three-phase 200 V class (220 V input power supply, without a power factor improving AC or DC reactor)

| Applicable inverter type<br>FR-E820-□ | Terminal screw size *4 | Tightening torque [Nm] | Crimping Terminal |         | Cable sizes                     |         |         |                   |                  |         |                                 |         |                   |
|---------------------------------------|------------------------|------------------------|-------------------|---------|---------------------------------|---------|---------|-------------------|------------------|---------|---------------------------------|---------|-------------------|
|                                       |                        |                        |                   |         | HIV, etc. [mm <sup>2</sup> ] *1 |         |         |                   | AWG/MCM *2       |         | PVC, etc. [mm <sup>2</sup> ] *3 |         |                   |
|                                       |                        |                        | R/L1, S/L2, T/L3  | U, V, W | R/L1, S/L2, T/L3                | U, V, W | P/+, P1 | Earth cable gauge | R/L1, S/L2, T/L3 | U, V, W | R/L1, S/L2, T/L3                | U, V, W | Earth cable gauge |
| 0008(0.1K) to 0050(0.75K)             | M3.5                   | 1.2                    | 2-3.5             | 2-3.5   | 2                               | 2       | 2       | 2                 | 14               | 14      | 2.5                             | 2.5     | 2.5               |
| 0080(1.5K), 0110(2.2K)                | M4                     | 1.5                    | 2-4               | 2-4     | 2                               | 2       | 2       | 2                 | 14               | 14      | 2.5                             | 2.5     | 2.5               |
| 0175(3.7K)                            | M4                     | 1.5                    | 5.5-4             | 5.5-4   | 3.5                             | 3.5     | 3.5     | 3.5               | 12               | 12      | 4                               | 4       | 4                 |
| 0240(5.5K)                            | M5                     | 2.5                    | 5.5-5             | 5.5-5   | 5.5                             | 5.5     | 5.5     | 5.5               | 10               | 10      | 6                               | 6       | 6                 |
| 0330(7.5K)                            | M5                     | 2.5                    | 14-5              | 8-5     | 14                              | 8       | 8       | 5.5               | 6                | 8       | 16                              | 10      | 6                 |
| 0470(11K)                             | M5                     | 2.5                    | 14-5              | 14-5    | 14                              | 14      | 14      | 8                 | 6                | 6       | 16                              | 16      | 16                |
| 0600(15K)                             | M6 (M5)                | 4.4                    | 22-6              | 22-6    | 22                              | 22      | 22      | 14                | 4                | 4       | 25                              | 25      | 16                |
| 0760(18.5K)                           | M8 (M6)                | 7.8                    | 38-8              | 22-8    | 38                              | 22      | 38      | 14                | 2                | 2       | 35                              | 25      | 25                |
| 0900(22K)                             | M8 (M6)                | 7.8                    | 38-8              | 38-8    | 38                              | 38      | 38      | 22                | 2                | 2       | 35                              | 35      | 25                |

- Three-phase 200 V class (220 V input power supply, with a power factor improving AC or DC reactor)

| Applicable inverter type<br>FR-E820-□ | Terminal screw size *4 | Tightening torque [Nm] | Crimping Terminal |         | Cable sizes                     |         |         |                   |                  |         |                                 |         |                   |
|---------------------------------------|------------------------|------------------------|-------------------|---------|---------------------------------|---------|---------|-------------------|------------------|---------|---------------------------------|---------|-------------------|
|                                       |                        |                        |                   |         | HIV, etc. [mm <sup>2</sup> ] *1 |         |         |                   | AWG/MCM *2       |         | PVC, etc. [mm <sup>2</sup> ] *3 |         |                   |
|                                       |                        |                        | R/L1, S/L2, T/L3  | U, V, W | R/L1, S/L2, T/L3                | U, V, W | P/+, P1 | Earth cable gauge | R/L1, S/L2, T/L3 | U, V, W | R/L1, S/L2, T/L3                | U, V, W | Earth cable gauge |
| 0008(0.1K) to 0050(0.75K)             | M3.5                   | 1.2                    | 2-3.5             | 2-3.5   | 2                               | 2       | 2       | 2                 | 14               | 14      | 2.5                             | 2.5     | 2.5               |
| 0080(1.5K), 0110(2.2K)                | M4                     | 1.5                    | 2-4               | 2-4     | 2                               | 2       | 2       | 2                 | 14               | 14      | 2.5                             | 2.5     | 2.5               |
| 0175(3.7K)                            | M4                     | 1.5                    | 5.5-4             | 5.5-4   | 3.5                             | 3.5     | 3.5     | 3.5               | 12               | 12      | 4                               | 4       | 4                 |
| 0240(5.5K)                            | M5                     | 2.5                    | 5.5-5             | 5.5-5   | 5.5                             | 5.5     | 5.5     | 5.5               | 10               | 10      | 6                               | 6       | 6                 |
| 0330(7.5K)                            | M5                     | 2.5                    | 8-5               | 8-5     | 8                               | 8       | 8       | 5.5               | 8                | 8       | 10                              | 10      | 6                 |
| 0470(11K)                             | M5                     | 2.5                    | 14-5              | 14-5    | 14                              | 14      | 14      | 8                 | 6                | 6       | 16                              | 16      | 16                |
| 0600(15K)                             | M6 (M5)                | 4.4                    | 22-6              | 22-6    | 22                              | 22      | 22      | 14                | 4                | 4       | 25                              | 25      | 16                |
| 0760(18.5K)                           | M8 (M6)                | 7.8                    | 22-8              | 22-8    | 22                              | 22      | 38      | 14                | 4                | 2       | 25                              | 25      | 25                |
| 0900(22K)                             | M8 (M6)                | 7.8                    | 38-8              | 38-8    | 38                              | 38      | 38      | 22                | 2                | 2       | 35                              | 35      | 25                |

- Three-phase 400 V class (440 V input power supply, without a power factor improving AC or DC reactor)

| Applicable inverter type<br>FR-E840-□ | Terminal screw size *4 | Tightening torque [Nm] | Crimping terminal |         | Cable sizes                     |         |         |                   |                  |         |                                 |         |                   |
|---------------------------------------|------------------------|------------------------|-------------------|---------|---------------------------------|---------|---------|-------------------|------------------|---------|---------------------------------|---------|-------------------|
|                                       |                        |                        |                   |         | HIV, etc. [mm <sup>2</sup> ] *1 |         |         |                   | AWG/MCM *2       |         | PVC, etc. [mm <sup>2</sup> ] *3 |         |                   |
|                                       |                        |                        | R/L1, S/L2, T/L3  | U, V, W | R/L1, S/L2, T/L3                | U, V, W | P/+, P1 | Earth cable gauge | R/L1, S/L2, T/L3 | U, V, W | R/L1, S/L2, T/L3                | U, V, W | Earth cable gauge |
| 0016(0.4K) to 0095(3.7K)              | M4                     | 1.5                    | 2-4               | 2-4     | 2                               | 2       | 2       | 2                 | 14               | 14      | 2.5                             | 2.5     | 2.5               |
| 0120(5.5K)                            | M4                     | 1.5                    | 5.5-4             | 2-4     | 3.5                             | 2       | 3.5     | 3.5               | 12               | 14      | 4                               | 2.5     | 4                 |
| 0170(7.5K)                            | M4                     | 1.5                    | 5.5-4             | 5.5-4   | 3.5                             | 3.5     | 3.5     | 3.5               | 12               | 12      | 4                               | 4       | 4                 |
| 0230(11K)                             | M4                     | 1.5                    | 5.5-4             | 5.5-4   | 5.5                             | 5.5     | 5.5     | 5.5               | 10               | 10      | 6                               | 6       | 10                |
| 0300(15K)                             | M5                     | 2.5                    | 8-5               | 8-5     | 8                               | 8       | 8       | 5.5               | 8                | 8       | 10                              | 10      | 10                |
| 0380(18.5K)                           | M6                     | 4.4                    | 14-6              | 8-6     | 14                              | 8       | 14      | 8                 | 6                | 6       | 16                              | 10      | 16                |
| 0440(22K)                             | M6                     | 4.4                    | 14-6              | 14-6    | 14                              | 14      | 22      | 14                | 6                | 6       | 16                              | 16      | 16                |



- Three-phase 400 V class (440 V input power supply, with a power factor improving AC or DC reactor)

| Applicable inverter type<br>FR-E840-□ | Terminal screw size *4 | Tightening torque [Nm] | Crimping terminal |         | Cable sizes                     |         |         |                   |                  |         |                                 |         |                   |
|---------------------------------------|------------------------|------------------------|-------------------|---------|---------------------------------|---------|---------|-------------------|------------------|---------|---------------------------------|---------|-------------------|
|                                       |                        |                        |                   |         | HIV, etc. [mm <sup>2</sup> ] *1 |         |         |                   | AWG/MCM *2       |         | PVC, etc. [mm <sup>2</sup> ] *3 |         |                   |
|                                       |                        |                        | R/L1, S/L2, T/L3  | U, V, W | R/L1, S/L2, T/L3                | U, V, W | P/+, P1 | Earth cable gauge | R/L1, S/L2, T/L3 | U, V, W | R/L1, S/L2, T/L3                | U, V, W | Earth cable gauge |
| 0016(0.4K) to 0095(3.7K)              | M4                     | 1.5                    | 2-4               | 2-4     | 2                               | 2       | 2       | 2                 | 14               | 14      | 2.5                             | 2.5     | 2.5               |
| 0120(5.5K)                            | M4                     | 1.5                    | 2-4               | 2-4     | 2                               | 2       | 3.5     | 2                 | 14               | 14      | 2.5                             | 2.5     | 2.5               |
| 0170(7.5K)                            | M4                     | 1.5                    | 5.5-4             | 5.5-4   | 3.5                             | 3.5     | 3.5     | 3.5               | 12               | 12      | 4                               | 4       | 4                 |
| 0230(11K)                             | M4                     | 1.5                    | 5.5-4             | 5.5-4   | 5.5                             | 5.5     | 5.5     | 5.5               | 10               | 10      | 6                               | 6       | 6                 |
| 0300(15K)                             | M5                     | 2.5                    | 8-5               | 8-5     | 8                               | 8       | 8       | 5.5               | 8                | 8       | 10                              | 10      | 10                |
| 0380(18.5K)                           | M6                     | 4.4                    | 8-6               | 8-6     | 8                               | 8       | 14      | 8                 | 8                | 8       | 10                              | 10      | 10                |
| 0440(22K)                             | M6                     | 4.4                    | 14-6              | 14-6    | 14                              | 14      | 22      | 14                | 6                | 6       | 16                              | 16      | 16                |

For footnotes \*1 to \*4 refer to next page.

- Single-phase 200 V class (220 V input power supply, without a power factor improving AC or DC reactor)

| Applicable inverter type<br>FR-E820S-□ | Terminal screw size *4 | Tightening torque [Nm] | Crimping terminal |         | Cable sizes                     |         |         |                   |                  |         |                                 |         |                   |
|--|------------------------|------------------------|-------------------|---------|---------------------------------|---------|---------|-------------------|------------------|---------|---------------------------------|---------|-------------------|
|  |                        |                        |                   |         | HIV, etc. [mm <sup>2</sup> ] *1 |         |         |                   | AWG/MCM *2       |         | PVC, etc. [mm <sup>2</sup> ] *3 |         |                   |
|  |                        |                        | R/L1, S/L2, T/L3  | U, V, W | R/L1, S/L2, T/L3                | U, V, W | P/+, P1 | Earth cable gauge | R/L1, S/L2, T/L3 | U, V, W | R/L1, S/L2, T/L3                | U, V, W | Earth cable gauge |
| 0008(0.1K) to 0030(0.4K)               | M3.5                   | 1.2                    | 2-3.5             | 2-3.5   | 2                               | 2       | 2       | 2                 | 14               | 14      | 2.5                             | 2.5     | 2.5               |
| 0050(0.75K), 0080(1.5K)                | M4                     | 1.5                    | 2-4               | 2-4     | 2                               | 2       | 2       | 2                 | 14               | 14      | 2.5                             | 2.5     | 2.5               |
| 0110(2.2K)                             | M4                     | 1.5                    | 5.5-4             | 2-4     | 3.5                             | 2       | 2       | 2                 | 12               | 14      | 4                               | 2.5     | 2.5               |

- Single-phase 200 V class (220 V input power supply, with a power factor improving AC or DC reactor)

| Applicable inverter type<br>FR-E820S-□ | Terminal screw size *4 | Tightening torque [Nm] | Crimping terminal |         | Cable sizes                     |         |         |                   |                  |         |                                 |         |                   |
|--|------------------------|------------------------|-------------------|---------|---------------------------------|---------|---------|-------------------|------------------|---------|---------------------------------|---------|-------------------|
|  |                        |                        |                   |         | HIV, etc. [mm <sup>2</sup> ] *1 |         |         |                   | AWG/MCM *2       |         | PVC, etc. [mm <sup>2</sup> ] *3 |         |                   |
|  |                        |                        | R/L1, S/L2, T/L3  | U, V, W | R/L1, S/L2, T/L3                | U, V, W | P/+, P1 | Earth cable gauge | R/L1, S/L2, T/L3 | U, V, W | R/L1, S/L2, T/L3                | U, V, W | Earth cable gauge |
| 0008(0.1K) to 0030(0.4K)               | M3.5                   | 1.2                    | 2-3.5             | 2-3.5   | 2                               | 2       | 2       | 2                 | 14               | 14      | 2.5                             | 2.5     | 2.5               |
| 0050(0.75K), 0080(1.5K)                | M4                     | 1.5                    | 2-4               | 2-4     | 2                               | 2       | 2       | 2                 | 14               | 14      | 2.5                             | 2.5     | 2.5               |
| 0110(2.2K)                             | M4                     | 1.5                    | 5.5-4             | 2-4     | 3.5                             | 2       | 2       | 2                 | 12               | 14      | 4                               | 2.5     | 2.5               |

\*1 The cable size is that of the HIV cable (600 V grade heat-resistant PVC insulated wire) etc. with continuous maximum permissible temperature of 75°C. It assumes a surrounding air temperature of 50°C or lower and the wiring distance of 20 m or shorter.

\*2 The cable size is that of the THHW cable with continuous maximum permissible temperature of 75°C. It assumes a surrounding air temperature of 40°C or lower and the wiring distance of 20 m or shorter.  
(For the use in the United States or Canada, refer to "Instructions for UL and cUL" in the document enclosed with the product.)

\*3 The cable size is that of the PVC cable with continuous maximum permissible temperature of 70°C. It assumes a surrounding air temperature of 40°C or lower and the wiring distance of 20 m or shorter.  
(Selection example mainly for use in Europe.)

\*4 The screw size for terminals R/L1, S/L2, T/L3, U, V, W, PR, P/+, N/-, and P1, and the earthing (grounding) terminal is shown. The screw size for earthing (grounding) the FR-E820-0600(15K) to FR-E820-0900(22K) is indicated in parentheses.

**For the LD rating**

- Three-phase 200 V class (220 V input power supply, without a power factor improving AC or DC reactor)

| Applicable inverter type<br>FR-E820-□ | Terminal screw size *1 | Tightening torque [Nm] | Crimping terminal |         | Cable sizes                     |         |         |                   |                  |         |                                 |         |                   |
|---------------------------------------|------------------------|------------------------|-------------------|---------|---------------------------------|---------|---------|-------------------|------------------|---------|---------------------------------|---------|-------------------|
|                                       |                        |                        |                   |         | HIV, etc. [mm <sup>2</sup> ] *2 |         |         |                   | AWG/MCM *3       |         | PVC, etc. [mm <sup>2</sup> ] *4 |         |                   |
|                                       |                        |                        | R/L1, S/L2, T/L3  | U, V, W | R/L1, S/L2, T/L3                | U, V, W | P/+, P1 | Earth cable gauge | R/L1, S/L2, T/L3 | U, V, W | R/L1, S/L2, T/L3                | U, V, W | Earth cable gauge |
| 0008(0.1K) to 0050(0.75K)             | M3.5                   | 1.2                    | 2-3.5             | 2-3.5   | 2                               | 2       | 2       | 2                 | 14               | 14      | 2.5                             | 2.5     | 2.5               |
| 0080(1.5K)                            | M4                     | 1.5                    | 2-4               | 2-4     | 2                               | 2       | 2       | 2                 | 14               | 14      | 2.5                             | 2.5     | 2.5               |
| 0110(2.2K)                            | M4                     | 1.5                    | 5.5-4             | 5.5-4   | 3.5                             | 3.5     | 3.5     | 3.5               | 12               | 12      | 4                               | 4       | 4                 |
| 0175(3.7K)                            | M4                     | 1.5                    | 5.5-4             | 5.5-4   | 5.5                             | 5.5     | 5.5     | 5.5               | 10               | 10      | 6                               | 6       | 6                 |
| 0240(5.5K)                            | M5                     | 2.5                    | 8-5               | 5.5-5   | 14                              | 5.5     | 14      | 5.5               | 6                | 10      | 16                              | 6       | 6                 |
| 0330(7.5K)                            | M5                     | 2.5                    | 14-5              | 14-5    | 14                              | 14      | 14      | 8                 | 6                | 6       | 16                              | 16      | 10                |
| 0470(11K)                             | M5                     | 2.5                    | 22-5              | 22-5    | 22                              | 22      | 22      | 14                | 4                | 4       | 25                              | 25      | 16                |
| 0600(15K)                             | M6                     | 4.4                    | 38-6              | 22-6    | 38                              | 22      | 38      | 14                | 2                | 4       | 35                              | 25      | 25                |
| 0760(18.5K)                           | M8 (M6)                | 7.8                    | 38-8              | 38-8    | 38                              | 38      | 38      | 22                | 2                | 2       | 35                              | 35      | 25                |
| 0900(22K)                             | M8 (M6)                | 7.8                    | 60-8              | 60-8    | 60                              | 60      | 60      | 22                | 1/0              | 1/0     | 50                              | 50      | 25                |

- Three-phase 200 V class (220 V input power supply, with a power factor improving AC or DC reactor)

| Applicable inverter type<br>FR-E820-□ | Terminal screw size *1 | Tightening torque [Nm] | Crimping terminal |         | Cable sizes                     |         |         |                   |                  |         |                                 |         |                   |
|---------------------------------------|------------------------|------------------------|-------------------|---------|---------------------------------|---------|---------|-------------------|------------------|---------|---------------------------------|---------|-------------------|
|                                       |                        |                        |                   |         | HIV, etc. [mm <sup>2</sup> ] *2 |         |         |                   | AWG/MCM *3       |         | PVC, etc. [mm <sup>2</sup> ] *4 |         |                   |
|                                       |                        |                        | R/L1, S/L2, T/L3  | U, V, W | R/L1, S/L2, T/L3                | U, V, W | P/+, P1 | Earth cable gauge | R/L1, S/L2, T/L3 | U, V, W | R/L1, S/L2, T/L3                | U, V, W | Earth cable gauge |
| 0008(0.1K) to 0050(0.75K)             | M3.5                   | 1.2                    | 2-3.5             | 2-3.5   | 2                               | 2       | 2       | 2                 | 14               | 14      | 2.5                             | 2.5     | 2.5               |
| 0080(1.5K)                            | M4                     | 1.5                    | 2-4               | 2-4     | 2                               | 2       | 2       | 2                 | 14               | 14      | 2.5                             | 2.5     | 2.5               |
| 0110(2.2K)                            | M4                     | 1.5                    | 5.5-4             | 5.5-4   | 3.5                             | 3.5     | 3.5     | 3.5               | 12               | 12      | 4                               | 4       | 4                 |
| 0175(3.7K)                            | M4                     | 1.5                    | 5.5-4             | 5.5-4   | 5.5                             | 5.5     | 5.5     | 5.5               | 10               | 10      | 6                               | 6       | 6                 |
| 0240(5.5K)                            | M5                     | 2.5                    | 5.5-5             | 5.5-5   | 5.5                             | 5.5     | 14      | 5.5               | 10               | 10      | 6                               | 6       | 6                 |
| 0330(7.5K)                            | M5                     | 2.5                    | 14-5              | 14-5    | 14                              | 14      | 14      | 8                 | 6                | 6       | 16                              | 16      | 10                |
| 0470(11K)                             | M5                     | 2.5                    | 22-5              | 22-5    | 22                              | 22      | 22      | 14                | 4                | 4       | 25                              | 25      | 16                |
| 0600(15K)                             | M6                     | 4.4                    | 22-6              | 22-6    | 22                              | 22      | 38      | 14                | 4                | 4       | 25                              | 25      | 25                |
| 0760(18.5K)                           | M8 (M6)                | 7.8                    | 38-8              | 38-8    | 38                              | 38      | 38      | 22                | 2                | 2       | 35                              | 35      | 25                |
| 0900(22K)                             | M8 (M6)                | 7.8                    | 60-8              | 60-8    | 60                              | 60      | 60      | 22                | 1/0              | 1/0     | 50                              | 50      | 25                |

- Three-phase 400 V class (440 V input power supply, without a power factor improving AC or DC reactor)

| Applicable inverter Type<br>FR-E840-□ | Terminal screw size *1 | Tightening torque [Nm] | Crimping terminal |         | Cable Sizes                     |         |         |                   |                  |         |                                 |         |                   |
|---------------------------------------|------------------------|------------------------|-------------------|---------|---------------------------------|---------|---------|-------------------|------------------|---------|---------------------------------|---------|-------------------|
|                                       |                        |                        |                   |         | HIV, etc. [mm <sup>2</sup> ] *2 |         |         |                   | AWG/MCM *3       |         | PVC, etc. [mm <sup>2</sup> ] *4 |         |                   |
|                                       |                        |                        | R/L1, S/L2, T/L3  | U, V, W | R/L1, S/L2, T/L3                | U, V, W | P/+, P1 | Earth cable gauge | R/L1, S/L2, T/L3 | U, V, W | R/L1, S/L2, T/L3                | U, V, W | Earth cable gauge |
| 0016(0.4K) to 0060(2.2K)              | M4                     | 1.5                    | 2-4               | 2-4     | 2                               | 2       | 2       | 2                 | 14               | 14      | 2.5                             | 2.5     | 2.5               |
| 0095(3.7K)                            | M4                     | 1.5                    | 2-4               | 2-4     | 2                               | 2       | 3.5     | 2                 | 12               | 14      | 2.5                             | 2.5     | 2.5               |
| 0120(5.5K)                            | M4                     | 1.5                    | 5.5-4             | 5.5-4   | 3.5                             | 3.5     | 3.5     | 3.5               | 12               | 12      | 4                               | 4       | 4                 |
| 0170(7.5K)                            | M4                     | 1.5                    | 5.5-4             | 5.5-4   | 5.5                             | 5.5     | 5.5     | 5.5               | 10               | 10      | 6                               | 6       | 6                 |
| 0230(11K)                             | M4                     | 1.5                    | 8-4               | 5.5-4   | 8                               | 5.5     | 8       | 5.5               | 8                | 10      | 10                              | 6       | 10                |
| 0300(15K)                             | M5                     | 2.5                    | 14-5              | 8-5     | 14                              | 8       | 14      | 8                 | 6                | 8       | 16                              | 10      | 16                |
| 0380(18.5K)                           | M6                     | 4.4                    | 14-6              | 14-6    | 14                              | 14      | 22      | 14                | 6                | 6       | 16                              | 16      | 16                |
| 0440(22K)                             | M6                     | 4.4                    | 22-6              | 22-6    | 22                              | 22      | 22      | 14                | 4                | 4       | 25                              | 25      | 16                |



- Three-phase 400 V class (440 V input power supply, with a power factor improving AC or DC reactor)

| Applicable inverter Type<br>FR-E840-□ | Terminal screw size *1 | Tightening torque [Nm] | Crimping terminal |         | Cable Sizes                     |         |         |                   |                  |         |                                 |         |                   |
|---------------------------------------|------------------------|------------------------|-------------------|---------|---------------------------------|---------|---------|-------------------|------------------|---------|---------------------------------|---------|-------------------|
|                                       |                        |                        |                   |         | HIV, etc. [mm <sup>2</sup> ] *2 |         |         |                   | AWG/MCM *3       |         | PVC, etc. [mm <sup>2</sup> ] *4 |         |                   |
|                                       |                        |                        | R/L1, S/L2, T/L3  | U, V, W | R/L1, S/L2, T/L3                | U, V, W | P/+, P1 | Earth cable gauge | R/L1, S/L2, T/L3 | U, V, W | R/L1, S/L2, T/L3                | U, V, W | Earth cable gauge |
| 0016(0.4K) to 0060(2.2K)              | M4                     | 1.5                    | 2-4               | 2-4     | 2                               | 2       | 2       | 2                 | 14               | 14      | 2.5                             | 2.5     | 2.5               |
| 0095(3.7K)                            | M4                     | 1.5                    | 2-4               | 2-4     | 2                               | 2       | 3.5     | 2                 | 14               | 14      | 2.5                             | 2.5     | 2.5               |
| 0120(5.5K)                            | M4                     | 1.5                    | 5.5-4             | 5.5-4   | 3.5                             | 3.5     | 3.5     | 3.5               | 12               | 12      | 4                               | 4       | 4                 |
| 0170(7.5K)                            | M4                     | 1.5                    | 5.5-4             | 5.5-4   | 5.5                             | 5.5     | 5.5     | 5.5               | 10               | 10      | 6                               | 6       | 6                 |
| 0230(11K)                             | M4                     | 1.5                    | 5.5-4             | 5.5-4   | 5.5                             | 5.5     | 8       | 5.5               | 10               | 10      | 6                               | 6       | 6                 |
| 0300(15K)                             | M5                     | 2.5                    | 8-5               | 8-5     | 8                               | 8       | 14      | 8                 | 8                | 8       | 10                              | 10      | 10                |
| 0380(18.5K)                           | M6                     | 4.4                    | 14-6              | 14-6    | 14                              | 14      | 22      | 14                | 6                | 6       | 16                              | 16      | 16                |
| 0440(22K)                             | M6                     | 4.4                    | 22-6              | 22-6    | 22                              | 22      | 22      | 14                | 4                | 4       | 25                              | 25      | 16                |

\*1 The cable size is that of the HIV cable (600 V grade heat-resistant PVC insulated wire) etc. with continuous maximum permissible temperature of 75°C. It assumes a surrounding air temperature of 50°C or lower and the wiring distance of 20 m or shorter.

\*2 The cable size is that of the THHW cable with continuous maximum permissible temperature of 75°C. It assumes a surrounding air temperature of 40°C or lower and the wiring distance of 20 m or shorter.  
(For the use in the United States or Canada, refer to "Instructions for UL and cUL" in the document enclosed with the product.)

\*3 The cable size is that of the PVC cable with continuous maximum permissible temperature of 70°C. It assumes a surrounding air temperature of 40°C or lower and the wiring distance of 20 m or shorter.  
(Selection example mainly for use in Europe.)

\*4 The screw size for terminals R/L1, S/L2, T/L3, U, V, W, PR, P/+, N/-, and P1, and the earthing (grounding) terminal is shown. The screw size for earthing (grounding) the FR-E820-0760(18.5K) or FR-E820-0900(22K) is indicated in parentheses.

The line voltage drop can be calculated by the following formula:

$$\text{Line voltage drop [V]} = \frac{\sqrt{3} \times \text{wire resistance [m}\Omega\text{/m]} \times \text{wiring distance [m]} \times \text{current [A]}}{1000}$$

Use a larger diameter cable when the wiring distance is long or when it is desired to decrease the voltage drop (torque reduction) in the low speed range.

**CAUTION**

- Tighten the terminal screw to the specified torque.  
A screw that has been tightened too loosely can cause a short circuit or malfunction.  
A screw that has been tightened too tightly can cause a short circuit or malfunction due to the unit breakage.
- Use crimp terminals with insulation sleeves to wire the power supply and motor.

### 2.3.2 Total wiring length

#### • With induction motor

Connect one or more general-purpose motors within the total wiring length shown in the following table.

| Cable type | Pr.72 setting (carrier frequency) | Voltage class | 0.1K  | 0.2K  | 0.4K  | 0.75K | 1.5K  | 2.2K  | 3.7K or higher |
|------------|-----------------------------------|---------------|-------|-------|-------|-------|-------|-------|----------------|
| Unshielded | 1 (1 kHz) or lower                | 200 V         | 200 m | 200 m | 300 m | 500 m | 500 m | 500 m | 500 m          |
|            |                                   | 400 V         | —     | —     | 200 m | 200 m | 300 m | 500 m | 500 m          |
|            | 2 (2 kHz) or higher               | 200 V         | 30 m  | 100 m | 200 m | 300 m | 500 m | 500 m | 500 m          |
|            |                                   | 400 V         | —     | —     | 30 m  | 100 m | 200 m | 200 m | 500 m          |
| Shielded   | 1 (1 kHz) or lower                | 200 V         | 50 m  | 50 m  | 75 m  | 100 m | 100 m | 100 m | 100 m          |
|            |                                   | 400 V         | —     | —     | 50 m  | 50 m  | 75 m  | 100 m | 100 m          |
|            | 2 (2 kHz) or higher               | 200 V         | 10 m  | 25 m  | 50 m  | 75 m  | 100 m | 100 m | 100 m          |
|            |                                   | 400 V         | —     | —     | 10 m  | 25 m  | 50 m  | 75 m  | 100 m          |

Total wiring length (FR-E820-0175(3.7K) or higher, FR-E840-0095(3.7K) or higher)

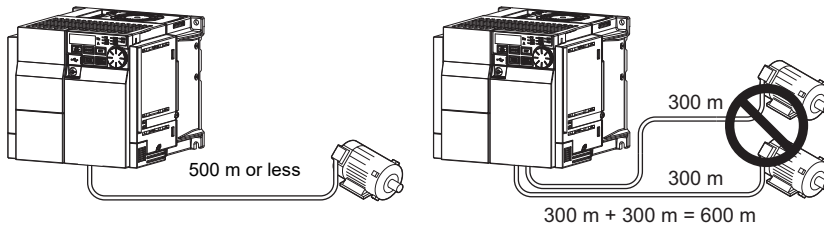

When driving a 400 V class motor by the inverter, surge voltages attributable to the wiring constants may occur at the motor terminals, deteriorating the insulation of the motor. In this case, take one of the following measure.

- Use a "400 V class inverter-driven insulation-enhanced motor" and set Pr.72 PWM frequency selection according to the wiring length.

| Wiring length 50 m or shorter | Wiring length 50 to 100 m | Wiring length longer than 100 m |
|-------------------------------|---------------------------|---------------------------------|
| 14.5 kHz or lower             | 8 kHz or lower            | 2 kHz or lower                  |

#### • With PM motor

Use the wiring length of 100 m or shorter when connecting a PM motor.

Use one PM motor for one inverter. Multiple PM motors cannot be connected to an inverter.

When the wiring length exceeds 50 m for a 400 V class motor driven by an inverter under PM sensorless vector control, set "9" (6 kHz) or less in **Pr.72 PWM frequency selection**.

#### CAUTION

- Especially for long-distance wiring, the inverter may be affected by a charging current caused by stray capacitances of the wiring, leading to an activation of the overcurrent protection, malfunction of the fast-response current limit operation, or even to an inverter failure. It may also cause a malfunction or fault of the equipment connected ON the inverter output side. If the fast-response current limit function malfunctions, disable the function. (Refer to **Pr.156 Stall prevention operation selection** in the FR-E800 Instruction Manual (Function).)
- A surge voltage suppression filter (FR-ASF-H/FR-BMF-H) can be used under V/F control and Advanced magnetic flux vector control.
- For the details of **Pr.72 PWM frequency selection**, refer to the FR-E800 Instruction Manual (Function).
- Refer to Instruction Manual (Connection) to drive a 400 V class motor by an inverter.
- The carrier frequency is limited during Real sensorless vector control and PM sensorless vector control. (Refer to the FR-E800 Instruction Manual (Function).)



### 2.3.3 Earthing (grounding) precautions

Always earth (ground) the motor and inverter.

#### Purpose of earthing (grounding)

Generally, an electrical apparatus has an earth (ground) terminal, which must be connected to the ground before use. An electrical circuit is usually insulated by an insulating material and encased. However, it is impossible to manufacture an insulating material that can shut off a leakage current completely, and actually, a slight current flows into the case. The purpose of earthing (grounding) the case of an electrical apparatus is to prevent operators from getting an electric shock from this leakage current when touching it.

To avoid the influence of external noises, the earthing (grounding) is important to EMI-sensitive equipment that handle low-level signals or operate very fast such as audio equipment, sensors, and computers.

#### Earthing (grounding) system to be established

As described previously, the purpose of earthing (grounding) is roughly classified into the electrical shock prevention and the prevention of malfunction due to the influence of electromagnetic noise. These two purposes should be clearly distinguished, and the appropriate earth (ground) system must be established to prevent the leakage current having the inverter's high frequency components from reversing through another earth (ground) point for malfunction prevention by following these instructions:

- Make the separate earth (ground) connection (I) for high frequency products such as the inverter from any other devices (EMI-sensitive devices described above) wherever possible.

Establishing adequate common (single-point) earth (ground) system (II) shown in the following figure is allowed only in cases where the separate earth (ground) system (I) is not feasible. Do not make inadequate common (single-point) earth (ground) connection (III).

As leakage currents containing many high frequency components flows into the earthing (grounding) cables of the inverter and peripheral devices (including a motor), the inverter must also be earthed (grounded) separately from EMI-sensitive devices described above.

In a high building, it may be effective to use its iron structure frames as earthing (grounding) electrode for EMI prevention in order to separate from the earth (ground) system for electric shock prevention.

- Earthing (Grounding) must conform to the requirements of national and local safety regulations and electrical codes (NEC section 250, IEC 61140 class 1 and other applicable standards). A neutral-point earthed (grounded) power supply for 400 V class inverter in compliance with EN standard must be used.
- Use the thickest possible earthing (grounding) cable. The earthing (grounding) cable should be the size indicated in the table on *page 17*.
- The earthing (grounding) point should be as close as possible to the inverter, and the earth (ground) wire length should be as short as possible.
- Run the earthing (grounding) cable as far away as possible from the I/O wiring of the EMI-sensitive devices and run them in parallel in the minimum distance.

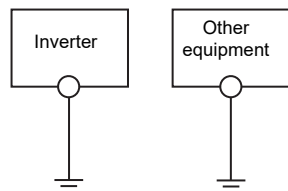

(I) Separate earthing (grounding): Good

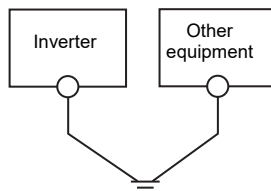

(II) Common (single-point) earthing (grounding): OK

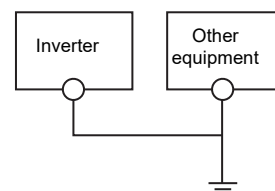

(III) Inadequate common (single-point) earthing (grounding): Bad

#### CAUTION

- To be compliant with the EU Directive (Low Voltage Directive), refer to the document enclosed with the product.

## 2.4 Control circuit terminals

### 2.4.1 Terminal layout

#### Standard model (FM type inverter)

- Recommended cable gauge: 0.3 to 0.75 mm<sup>2</sup>

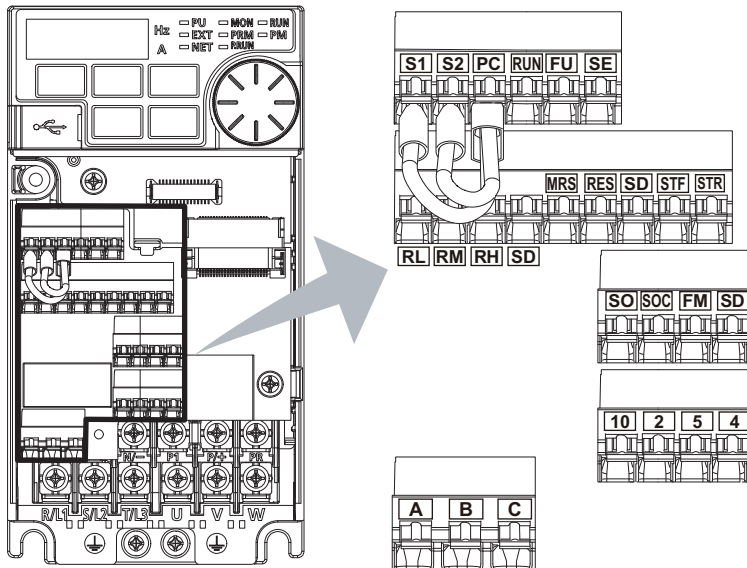

#### Standard model (AM type inverter)

- Recommended cable gauge: 0.3 to 0.75 mm<sup>2</sup>

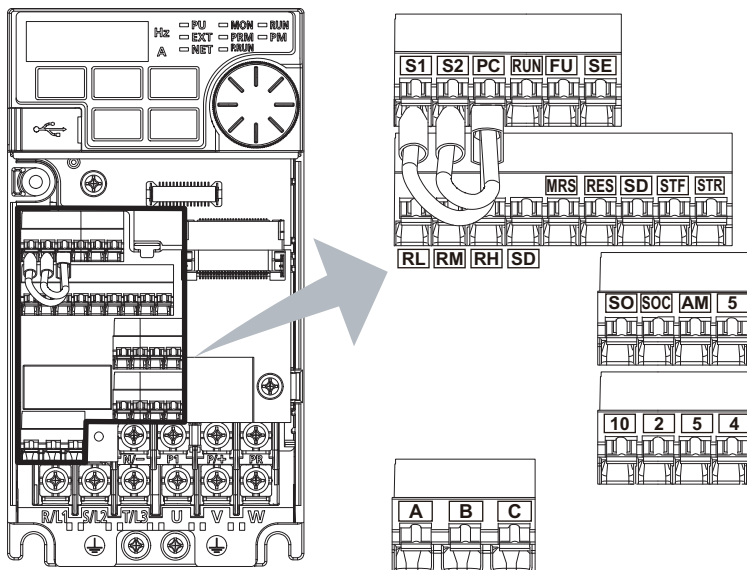



**Ethernet model**

- Recommended cable gauge: 0.3 to 0.75 mm<sup>2</sup>

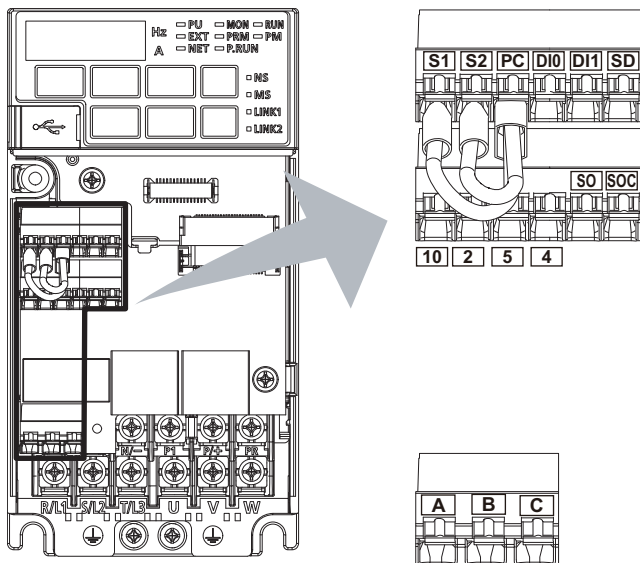

**Safety communication model**

- Recommended cable gauge: 0.3 to 0.75 mm<sup>2</sup>

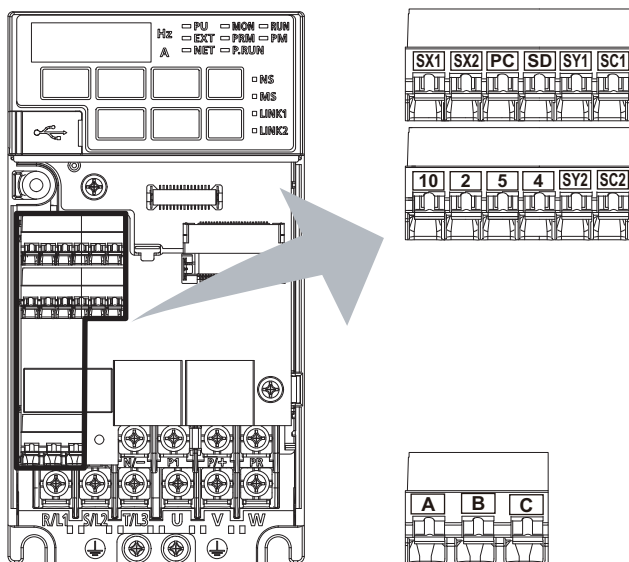

**2.4.2 Wiring method**

- Power supply connection

For the control circuit wiring, strip off the sheath of a cable, and use it with a blade terminal. For a single wire, strip off the sheath of the wire and apply directly. Insert the blade terminal or the single wire into a socket of the terminal.

- (1) Strip off the sheath for the below length. If the length of the sheath peeled is too long, a short circuit may occur with neighbouring wires. If the length is too short, wires might come off. Wire the stripped cable after twisting it to prevent it from becoming loose. In addition, do not solder it.

Cable sheath stripping length

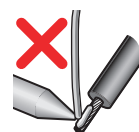
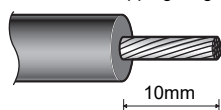

- (2) Insert wires into a blade terminal, then crimp the terminal.  
 Insert wires to a blade terminal, and check that the wires come out for about 0 to 0.5 mm from a sleeve.  
 Check the condition of the blade terminal after crimping. Do not use a blade terminal of which the crimping is inappropriate, or the face is damaged.

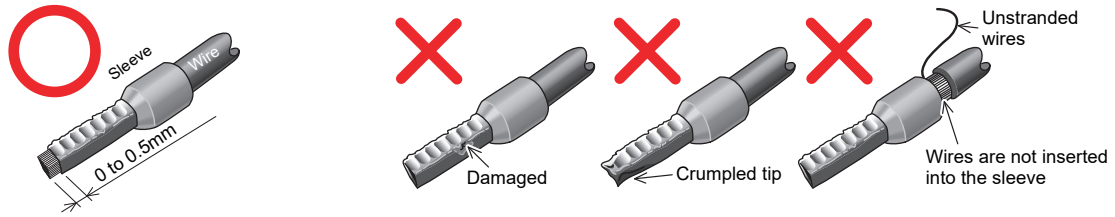

- Blade terminals commercially available (as of May 2016)

| Cable gauge (mm <sup>2</sup> ) | Blade terminal model   |                           | Manufacturer              | Crimping tool name |
|--------------------------------|------------------------|---------------------------|---------------------------|--------------------|
|                                | With insulation sleeve | Without insulation sleeve |                           |                    |
| 0.3                            | AI 0,34-10TQ           | —                         | Phoenix Contact Co., Ltd. | CRIMPFOX 6         |
| 0.5                            | AI 0,5-10WH            | —                         |                           |                    |
| 0.75                           | AI 0,75-10GY           | A 0,75-10                 |                           |                    |
| 1                              | AI 1-10RD              | A 1-10                    |                           |                    |
| 1.25, 1.5                      | AI 1,5-10BK            | A 1,5-10                  |                           |                    |
| 0.75 (for two wires)           | AI-TWIN 2×0,75-10GY    | —                         |                           |                    |

| Cable gauge (mm <sup>2</sup> ) | Blade terminal product number | Insulation product number | Manufacturer     | Crimping tool product number |
|--------------------------------|-------------------------------|---------------------------|------------------|------------------------------|
| 0.3 to 0.75                    | BT 0.75-11                    | VC 0.75                   | NICHIFU Co.,Ltd. | NH 69                        |

- (3) Insert the wires into a socket.

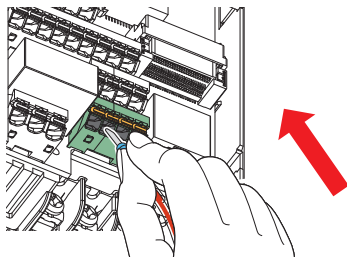

When using a single wire or stranded wires without a blade terminal, push the open/close button all the way down with a flathead screwdriver, and insert the wire.

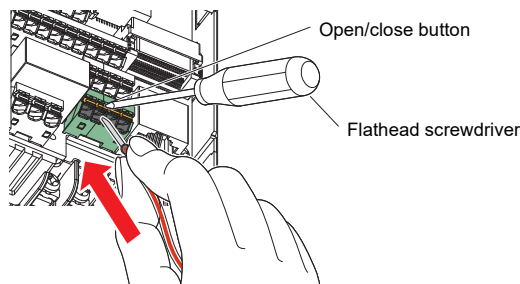

- Wire removal

Pull the wire while pushing the open/close button all the way down firmly with a flathead screwdriver.

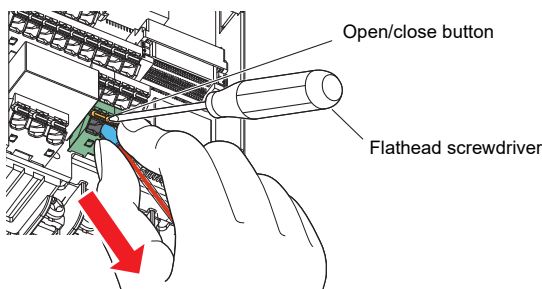

**CAUTION**

- Pulling out the wire forcefully without pushing the open/close button all the way down may damage the terminal block.
- Use a small flathead screwdriver (tip thickness: 0.4 mm / tip width: 2.5 mm).  
 If a flathead screwdriver with a narrow tip is used, terminal block may be damaged.  
 Commercially available products (as of April 2019)

| Name   | Model           | Manufacturer              |
|--------|-----------------|---------------------------|
| Driver | SZF 0-0,4 x 2,5 | Phoenix Contact Co., Ltd. |

- Place the flathead screwdriver vertical to the open/close button. In case the blade tip slips, it may cause an inverter damage or injury.



### 2.4.3 Wiring precautions

- It is recommended to use the cables of 0.3 to 0.75mm<sup>2</sup> gauge for connection to the control circuit terminals.
- The wiring length should be 30m (200m for the terminal FM) maximum.
- Use two or more parallel micro-signal contacts or twin contacts to prevent a contact faults when using contact inputs since the control circuit input signals are micro-currents.
- To suppress EMI, use shielded or twisted cables for the control circuit terminals and run them away from the main and power circuits (including the 200V relay sequence circuit). For the cables connected to the control circuit terminals, connect their shields to the common terminal of the connected control circuit terminal. When connecting an external power supply to the terminal PC, however, connect the shield of the power supply cable to the negative side of the external power supply. Do not directly earth the shield to the enclosure, etc.
- Always apply a voltage to the alarm output terminals (A1, B1, C1, A2, B2, C2) via a relay coil, lamp, etc.
- When a relay coil is connected to the output terminals, use one with a surge absorbing function (reflux diode). When the voltage application direction is incorrect, the inverter will be damaged. Pay attention to the diode direction or other precautions to avoid incorrect wiring.

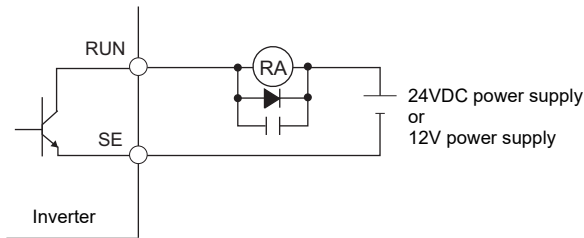
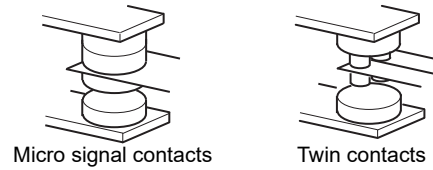

### 2.4.4 Control logic (sink/source) change (Standard model / Ethernet model)

The control logic of input signals can be switched as necessary for the standard model and the Ethernet model. To change the control logic, change the DIP switch position on the control circuit board. The initial setting of the control logic differs depending on the specification. (The output signals may be used in either the sink or source logic independently of the switch setting.)

• Standard model

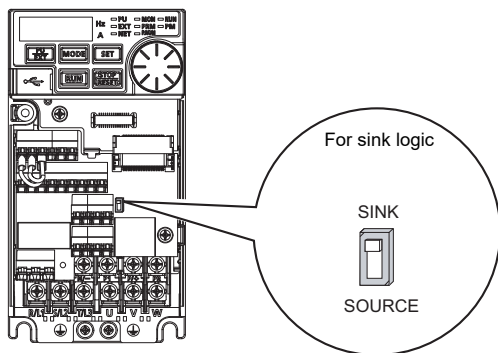

• Ethernet model

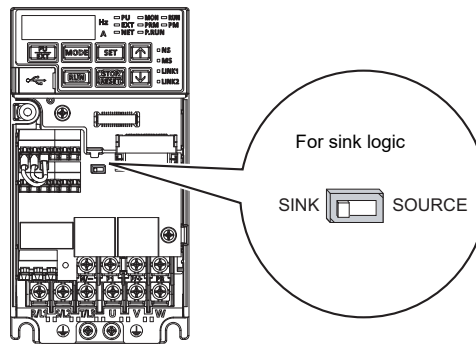

**CAUTION**

- Never change the control logic while power is ON.

## 2.5 Safety stop function

### 2.5.1 Function description

The terminals related to the safety stop function are shown below.

| Terminal symbol   | Terminal function description  |  |
|-------------------|--|--|
| S1 * <sup>1</sup> | Input terminal as the safety stop channel 1.   | Status of both the circuit between terminals S1 and PC and the circuit between terminals S2 and PC<br>Open: Safety stop is activated.<br>Shorted: Safety stop is not activated |
| S2 * <sup>1</sup> | Input terminal as the safety stop channel 2.   |  |
| PC * <sup>1</sup> | Common terminal for S1 and S2.   |  |
| SO                | Output terminal used for fault detection and fault indication display.<br>The terminal is ON (conducted) while no internal safety circuit failure * <sup>2</sup> exists. | OFF: Internal safety circuit failure * <sup>2</sup><br>ON: No internal safety circuit failure * <sup>2</sup>   |
| SOC               | Open collector output (terminal SO) common   |  |

\*<sup>1</sup> In the initial status, terminals S1 and PC and terminals S2 and PC are respectively shorted with shorting wires. To use the safety stop function, remove all the shorting wires, and then connect to the safety relay module as shown in the connection diagram.

\*<sup>2</sup> When any fault listed on the next page occurs in the internal safety circuit, the corresponding indication is shown on the operation panel.

#### CAUTION

- Use the terminal SO to output a fault and to prevent restarting of the inverter. The signal cannot be used as safety stop input signal to other devices.

### 2.5.2 Connection diagram

To prevent automatic restart after a fault occurrence, connect the reset button of a safety relay module or a safety programmable controller across the terminals SO and SOC. The reset button acts as the feedback input for the safety relay module or the safety programmable controller.

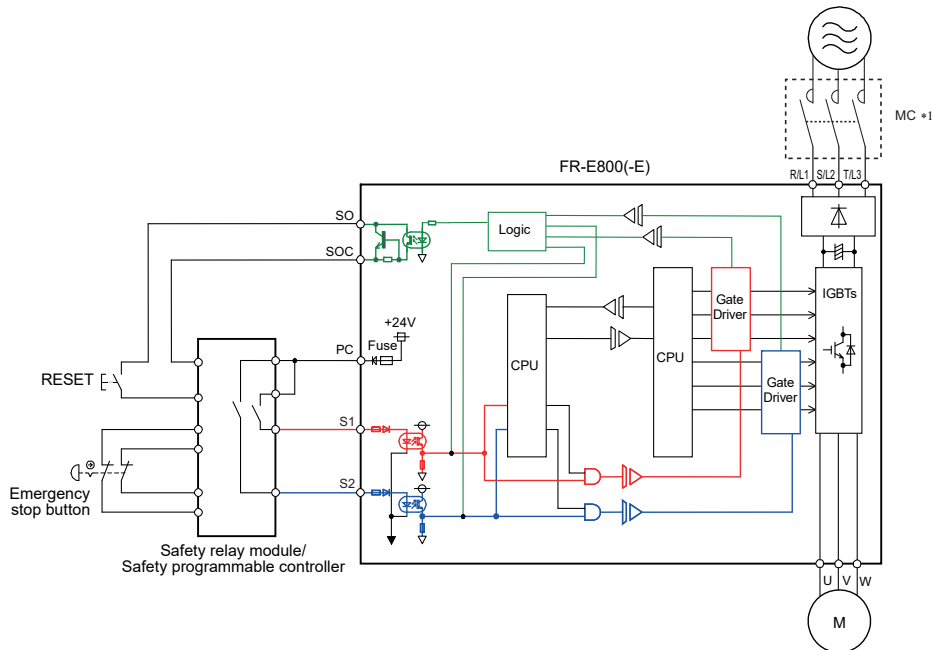

\*<sup>1</sup> To avoid an electric shock hazard, install a magnetic contactor (MC) at the input side of the inverter.



### 2.5.3 Safety stop function operation

| Input power | Internal safety circuit status | Input terminal *1, *2 |     | Output terminal | Output signal *8, *9, *10 |        | Inverter operation enable signal | Operation panel indication |                  |
|-------------|--------------------------------|-----------------------|-----|-----------------|---------------------------|--------|----------------------------------|----------------------------|------------------|
|             |                                | S1                    | S2  |                 | SO                        | SAFE   |                                  | SAFE2                      | E.SAF *6         |
| OFF         | —                              | —                     | —   | OFF             | OFF                       | OFF    | Output shutoff (Safe state)      | Not displayed              | Not displayed    |
| ON          | Normal                         | ON                    | ON  | ON *3           | OFF                       | ON *3  | Operation enabled                | Not displayed              | Not displayed    |
|             | Normal                         | ON                    | OFF | OFF *4          | OFF *4                    | OFF *4 | Output shutoff (Safe state)      | Displayed                  | Displayed        |
|             | Normal                         | OFF                   | ON  | OFF *4          | OFF *4                    | OFF *4 | Output shutoff (Safe state)      | Displayed                  | Displayed        |
|             | Normal                         | OFF                   | OFF | ON *3           | ON *3                     | ON *3  | Output shutoff (Safe state)      | Not displayed              | Displayed        |
|             | Fault                          | ON                    | ON  | OFF             | OFF                       | OFF    | Output shutoff (Safe state)      | Displayed                  | Not displayed *5 |
|             | Fault                          | ON                    | OFF | OFF             | OFF                       | OFF    | Output shutoff (Safe state)      | Displayed                  | Displayed        |
|             | Fault                          | OFF                   | ON  | OFF             | OFF                       | OFF    | Output shutoff (Safe state)      | Displayed                  | Displayed        |
|             | Fault                          | OFF                   | OFF | OFF             | OFF                       | OFF    | Output shutoff (Safe state)      | Displayed                  | Displayed        |

- \*1 The terminal ON state shows that the terminal is conducted (the line is closed), and the OFF state shows that the terminal is not conducted (the line is open).
- \*2 When not using the safety stop function, short across terminals S1 and PC and terminals S2 and PC to use the inverter. (In the initial status, terminals S1 and PC and terminals S2 and PC are respectively shorted with shorting wires.)
- \*3 If any of the faults shown in the following table occurs, terminal SO, the SAFE signal, and the SAFE2 signal are turned OFF.

| Error Definition                                       | Operation panel indication |
|--|----------------------------|
| Option fault   | E.OPT                      |
| Communication option fault                             | E.OP1                      |
| Parameter storage device fault (control circuit board) | E.PE                       |
| Retry count excess                                     | E.RET                      |
| Parameter storage device fault (main circuit board)    | E.PE2                      |
| Safety circuit fault                                   | E.SAF                      |
| Overspeed occurrence                                   | E.OS                       |
| Speed deviation excess detection                       | E.OSD                      |

| Error Definition         | Operation panel indication |
|--------------------------|----------------------------|
| Signal loss detection    | E.ECT                      |
| Excessive position fault | E.OD                       |
| Brake sequence fault     | E.MB1 to E.MB7             |
| Acceleration error       | E.OA                       |
| CPU fault                | E.CPU                      |
|                          | E.5 to E.7                 |
| Internal circuit fault   | E.13                       |

- \*4 When the internal safety circuit is operated normally (no fault occurs), terminal SO, the SAFE signal, and the SAFE2 signal remain ON until "E.SAF" is displayed. Terminal SO, the SAFE signal, and the SAFE2 signal are turned OFF when "E.SAF" is displayed.
- \*5 "SA" is displayed when terminals S1 and S2 are identified as OFF due to the internal safety circuit failure.
- \*6 If another fault occurs when the fault E.SAF occurs, the other fault indication may be displayed.
- \*7 If another warning occurs when the warning SA occurs, the other warning indication may be displayed.
- \*8 The ON/OFF state of the output signal is the one for the positive logic. In negative logic, the signal status is opposite.
- \*9 To assign the functions of the SAFE signal and SAFE2 signal to output terminals, set values shown in the following table in any two parameters from Pr.190 to Pr.196 (Output terminal function selection).

| Output signal | Pr.190 to Pr.196 setting |                |
|---------------|--------------------------|----------------|
|               | Positive logic           | Negative logic |
| SAFE          | 80                       | 180            |
| SAFE2         | 81                       | 181            |

- \*10 The use of the SAFE signal and SAFE2 signal has not been certified for compliance with safety standards. For details, refer to the FR-E800 Instruction Manual (Functional Safety).

### 2.5.4 Safety communication function (Safety communication model)

This function is not available for the standard model and the Ethernet model.

• **Outline**

Mitsubishi Electric FR-E800-SCE general-purpose inverters have safety functions to stop the output to motors.

By connecting the inverter with a programmable controller with an Ethernet cable, signal input via communication is enabled.

Wiring

The following describes terminals related to safety monitoring functions.

| Terminal symbol | Terminal function description  |
|-----------------|--|
| SX1             | Terminal functions can be selected using Pr.S051 SX1/SX2 terminal function selection.  |
| SX2             |  |
| SY1             | Terminal functions can be selected using Pr.S055 SY1/SY2 terminal function selection.  |
| SY2             |  |
| SD              | Connect this terminal to the power supply common terminal of a transistor output (open collector output) device, such as a programmable controller, in the source logic to avoid malfunction by undesirable current. |
| PC              | Common terminal for the 24 VDC power supply (terminal PC). Isolated from terminal 5.   |
|                 | Common terminal for SX1 and SX2.   |
| SC1             | Common terminal for SY1 and SY2.   |
|                 |  |
| SC2             |  |

• **Connection diagram.**

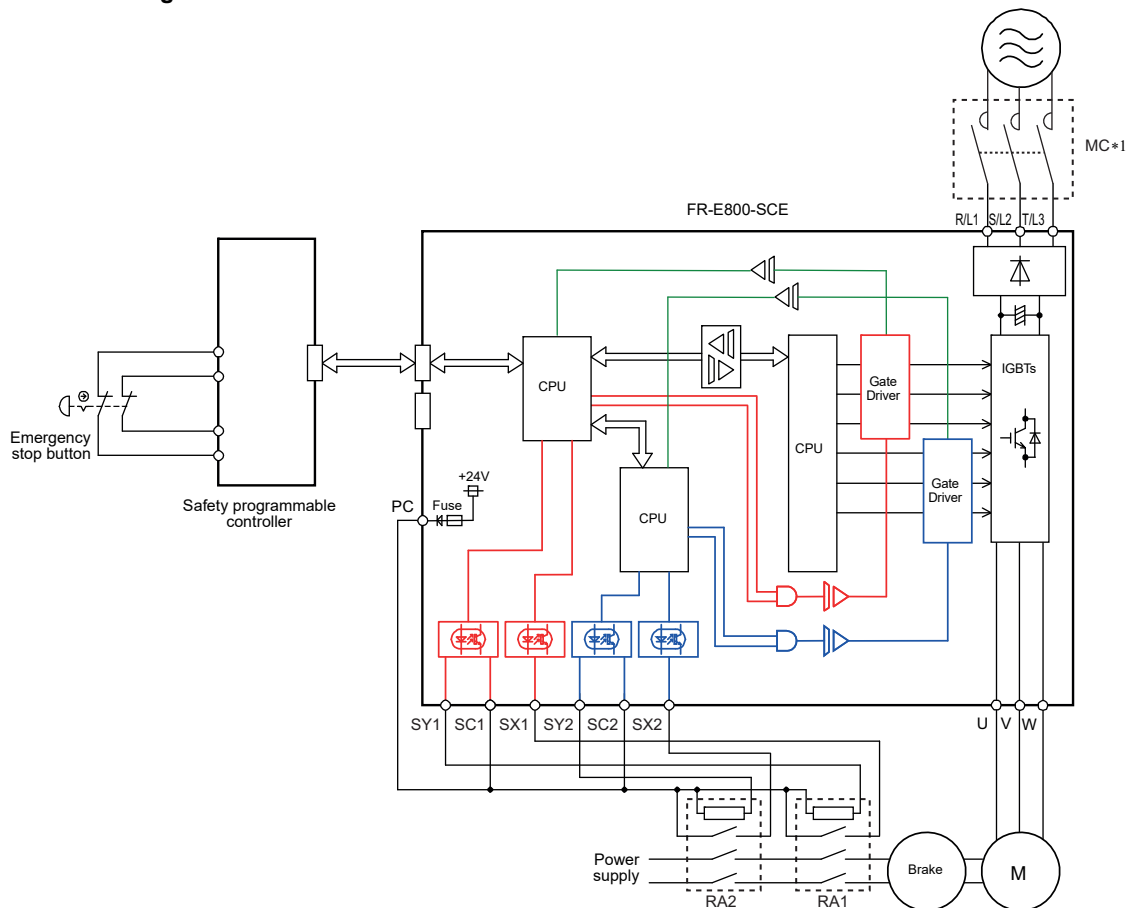

\*1 To avoid an electric shock hazard, install a magnetic contactor (MC) at the input side of the inverter.



• Operation of the SAFE and SAFE2 signals

| E.SAF indication *3 | Status of safety related parts | STO function status when the STO or SS1 command is input | Inverter operating status   | SA indication *4 | Output signal *5, *6, *7 |       |
|---------------------|--------------------------------|--|-----------------------------|------------------|--------------------------|-------|
|                     |                                |  |                             |                  | SAFE                     | SAFE2 |
| Not displayed       | Normal                         | STO disabled   | Operation enabled           | Not displayed    | OFF                      | ON*1  |
|                     |                                | STO disabled*2   | Output shutoff (Safe state) | Displayed        | ON*1                     | ON*1  |
| Displayed           | Fault                          | —  | Output shutoff (Safe state) | Not displayed    | OFF                      | OFF   |

\*1 If any of the faults shown in the following table occurs, the SAFE signal and the SAFE2 signal are turned OFF.

| Fault type   | Operation panel indication |
|--|----------------------------|
| Option Fault   | E.OPT                      |
| Communication option error                             | E.OP1                      |
| Parameter storage device fault (control circuit board) | E.PE                       |
| Retry count excess                                     | E.RET                      |
| Parameter storage device fault (main circuit board)    | E.PE2                      |
| Safety circuit fault                                   | E.SAF                      |
| Overspeed occurrence                                   | E.OS                       |
| Speed deviation excess detection                       | E.OSD                      |

| Fault type               | Operation panel indication |
|--------------------------|----------------------------|
| Signal loss detection    | E.ECT                      |
| Excessive position fault | E.OD                       |
| Brake sequence fault     | E.MB1 to E.MB7             |
| Acceleration error       | E.OA                       |
| CPU fault                | E.CPU                      |
|                          | E.5 to E.7                 |
| Internal circuit fault   | E.13                       |

\*2 When safety communication functions are enabled (Pr.S002 ≠ "0"), the STO function is enabled while the safety communication is not established.

\*3 If another fault occurs when the fault E.SAF occurs, the other fault indication may be displayed.

\*4 If another warning occurs when the warning SA occurs, the other warning indication may be displayed.

\*5 The ON/OFF state of the output signal is the one for the positive logic. In negative logic, the signal status is opposite.

\*6 To assign the functions of the SAFE signal and SAFE2 signal to output terminals, set either value shown in the following table in **Pr.192 ABC terminal function selection**. To output the signal via communication, the function can be assigned also to **Pr.190 to Pr.196 (Output terminal function selection)** using communication protocols. For details, refer to the Instruction Manual (Communication) or the Instruction Manual of each communication option.

| Output signal | Pr.190 to Pr.196 setting |                |
|---------------|--------------------------|----------------|
|               | Positive logic           | Negative logic |
| SAFE          | 80                       | 180            |
| SAFE2         | 81                       | 181            |

\*7 The use of the SAFE signal and SAFE2 signal has not been certified for compliance with safety standards.

For details, refer to the FR-E800-SCE Instruction Manual (Functional Safety).

### 3 FAILSAFE OF THE SYSTEM WHICH USES THE INVERTER

When a fault is detected by the protective function, the protective function activates and outputs the Fault signal. However, the Fault signal may not be output at an inverter's fault occurrence when the detection circuit or output circuit fails, etc. Although Mitsubishi assures the best quality products, provide an interlock which uses inverter status output signals to prevent accidents such as damage to the machine when the inverter fails for some reason. Also at the same time consider the system configuration where a failsafe from outside the inverter, without using the inverter, is enabled even if the inverter fails.

#### Interlock method which uses the inverter status output signals

By combining the inverter output signals to provide an interlock as shown below, an inverter failure can be detected. (For details of each signal, refer to the FR-E800 Instruction Manual (Function).)

| No. | Interlock method                       | Check method   | Used signals   |
|-----|--|--|--|
| a   | Inverter protective function operation | Operation check of an alarm contact.<br>Circuit error detection by negative logic. | Fault (ALM) signal   |
| b   | Inverter operating status              | Operation ready signal check.  | Inverter operation ready (RY) signal                               |
| c   | Inverter running status                | Logic check of the start signal and running signal.                                | Start (STF or STR) signal<br>Inverter running (RUN) signal         |
| d   | Inverter running status *1             | Logic check of the start signal and output current.                                | Start (STF or STR) signal<br>Output current detection (Y12) signal |

\*1 This interlock method cannot be used when a PM motor is used.

- When using various signals, assign the functions to Pr.190 to Pr.196 (Output terminal function selection) referring to the following table.

| Output signal | Pr.190 to Pr.196 settings |                |
|---------------|---------------------------|----------------|
|               | Positive logic            | Negative logic |
| ALM           | 99                        | 199            |
| RY            | 11                        | 111            |
| RUN           | 0                         | 100            |
| Y12           | 12                        | 112            |

#### CAUTION

- Changing the terminal assignment using Pr.190 to Pr.196 (Output terminal function selection) may affect the other functions. Set parameters after confirming the function of each terminal.

#### Checking by using the Fault signal output from the inverter... (a)

When the inverter's protective function is activated and the inverter output is stopped, the Fault (ALM) signal is output. (The ALM signal is assigned to terminals A, B, and C in the initial setting). With this signal, check that the inverter operates properly. In addition, negative logic can be set. (ON when the inverter is normal, OFF when the fault occurs.)

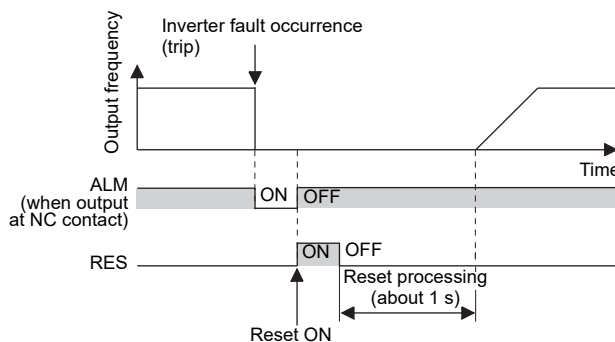

#### Checking the inverter operating status by using the Inverter operation ready signal output from the inverter ... (b)

The Inverter operation ready (RY) signal is output when the inverter power is ON and the inverter becomes operative. Check if the RY signal is output after powering ON the inverter.



**Checking the inverter operating status by using the start signal input to the inverter and the Inverter running signal output from the inverter ... (c)**

The Inverter running (RUN2) signal is output when the inverter is running. Check if the RUN2 signal is output while a start signal (the STF/STR signal for forward/reverse rotation command) is input to the inverter. Even after the start signal is turned OFF, the RUN2 signal is kept output until the inverter makes the motor to decelerate and to stop. For the logic check, configure a sequence considering the inverter's deceleration time.

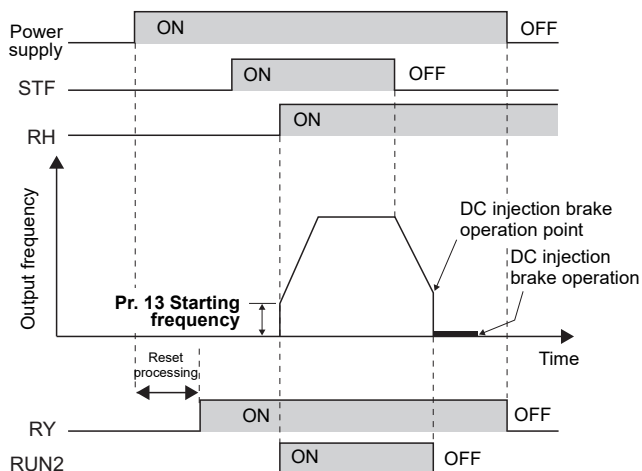

**Checking the motor operating status by using the start signal input to the inverter and the Output current detection signal output from the inverter ... (d)**

This interlock method cannot be used when a PM motor is used.

The Output current detection (Y12) signal is output when the inverter operates and currents flows into the motor.

Check if the Y12 signal is output while a start signal (the STF/STR signal for forward/reverse rotation command) is input to the inverter. The Y12 signal is initially set to be output at 150% inverter rated current. Adjust the level to around 20% using no load current of the motor as reference with **Pr.150 Output current detection level**.

Like the Inverter running (RUN) signal, even after the start signal is turned OFF, the Y12 signal is kept output until the inverter stops the output to a decelerating motor. For the logic check, configure a sequence considering the inverter's deceleration time.

**Backup method which does not use the inverter**

Even if the interlock is provided by the inverter status signal, enough failsafe is not ensured depending on the failure status of the inverter itself. For example, if an inverter CPU fails in a system interlocked with the inverter's Fault, start, and RUN signals, no Fault signals will be output and the RUN signal will be kept ON because the inverter CPU is down.

Provide a speed detector to detect the motor speed and current detector to detect the motor current, and consider the backup system such as performing a check as follows according to the level of importance of the system.

**Start signal and actual operation check**

Check the motor running and motor current while the start signal is input to the inverter by comparing the start signal to the inverter and detected speed of the speed detector or detected current of the current detector. Note that the current is flowing through the motor while the motor coasts to stop, even after the inverter's start signal is turned OFF. For the logic check, configure a sequence considering the inverter's deceleration time. In addition, it is recommended to check the three-phase current when using the current detector.

**Command speed and actual operation check**

Check for a gap between the actual speed and commanded speed by comparing the inverter's speed command and the speed detected by the speed detector.

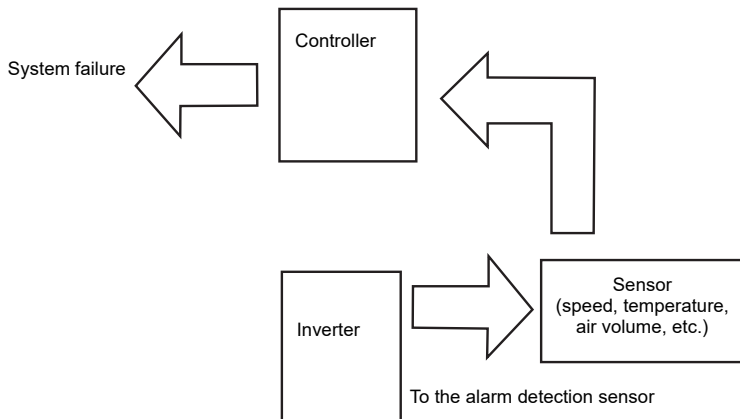

## 4 PRECAUTIONS FOR USE OF THE INVERTER

The FR-E800 series inverter is a highly reliable product, but incorrect peripheral circuit making or operation/handling method may shorten the product life or damage the product. Before starting operation, always recheck the following points.

| Checkpoint   | Countermeasure  |
|--|---|
| Crimp terminals are insulated.   | Use crimp terminals with insulation sleeves to wire the power supply and the motor.   |
| The wiring between the power supply (terminals R/L1, S/L2, T/L3) and the motor (terminals U, V, W) is correct.   | Application of power to the output terminals (U, V, W) of the inverter will damage the inverter. Never perform such wiring.   |
| No wire offcuts are left from the time of wiring.  | Wire offcuts can cause a fault, failure, or malfunction. Always keep the inverter clean. When drilling mounting holes in an enclosure etc., take caution not to allow chips and other foreign matter to enter the inverter.   |
| The main circuit cable gauge is correctly selected.  | Use an appropriate cable gauge to suppress the voltage drop to 2% or less. If the wiring distance is long between the inverter and motor, a voltage drop in the main circuit will cause the motor torque to decrease especially during the output of a low frequency.   |
| The total wiring length is within the specified length.  | Keep the total wiring length within the specified length. In long distance wiring, charging currents due to stray capacitance in the wiring may degrade the fast-response current limit operation or cause the equipment on the inverter's output side to malfunction. Pay attention to the total wiring length.  |
| Countermeasures are taken against EMI.   | The input/output (main circuit) of the inverter includes high frequency components, which may interfere with the communication devices (such as AM radios) used near the inverter. Connect radio noise filters or EMC filters on the input side of the inverter to minimize interference.   |
| On the inverter's output side, there is no power factor correction capacitor, surge suppressor, or radio noise filter installed.                           | Doing so will shut off the inverter output or damage the capacitor or surge suppressor. If any of the above devices is connected, immediately remove it.  |
| When performing an inspection or rewiring on the product that has been energized, the operator has waited long enough after shutting off the power supply. | For a short time after the power-OFF, a high voltage remains in the smoothing capacitor, and it is dangerous. Before performing an inspection or rewiring, wait 10 minutes or longer after the power supply turns OFF, then confirm that the voltage across the main circuit terminals P/+ and N/- of the inverter is low enough using a digital multimeter, etc.   |
| The inverter's output side has no short circuit or ground fault occurring.   | A short circuit or ground fault on the inverter's output side may damage the inverter module. Fully check the insulation resistance of the circuit prior to inverter operation since repeated short circuits caused by peripheral circuit inadequacy or an earth (ground) fault caused by wiring inadequacy or reduced motor insulation resistance may damage the inverter module. Fully check the to-earth (ground) insulation and phase-to-phase insulation of the inverter's output side before power-ON. Especially for an old motor or use in hostile atmosphere, securely check the motor insulation resistance, etc.                                 |
| The circuit is not configured to use the inverter's input-side magnetic contactor to start/stop the inverter frequently.                                   | Since repeated inrush currents at power ON will shorten the life of the converter circuit, frequent starts and stops of the magnetic contactor must be avoided. Turn ON or OFF the inverter's start (STF/STR) signal to run or stop the inverter.   |
| A mechanical brake is not connected to terminals P/+ and PR.   | To terminals P/+ and PR, connect only an external brake resistor.   |
| The voltage applied to the inverter I/O signal circuits is within the specifications.  | Application of a voltage higher than the permissible voltage to the inverter I/O signal circuits or opposite polarity may damage the I/O devices.   |
| When using the electronic bypass operation, electrical and mechanical interlocks are provided between the electronic bypass contactors MC1 and MC2.        | <p>When using a switching circuit as shown below, chattering due to misconfigured sequence or arc generated at switching may allow undesirable current to flow in and damage the inverter. Miswiring may also damage the inverter. (Note that a PM motor cannot be driven by the commercial power supply.)</p> <p>If switching to the commercial power supply operation while a failure such as an output short circuit has occurred between the magnetic contactor MC2 and the motor, the damage may further spread. If a failure has occurred between the MC2 and the motor, a protection circuit such as using the OH signal input must be provided.</p> |
| A countermeasure is provided for power restoration after a power failure.  | If the machine must not be restarted when power is restored after a power failure, provide an MC on the inverter's input side and also make up a sequence which will not switch ON the start signal. If the start signal (start switch) remains ON after a power failure, the inverter will automatically restart as soon as the power is restored.   |
| For Vector control, the encoder is properly installed.   | The encoder must be directly connected to a motor shaft without any backlash. (Real sensorless vector control or PM sensorless vector control does not require an encoder.)   |



| Checkpoint  | Countermeasure   |
|---|--|
| A magnetic contactor (MC) is installed on the inverter's input side.                              | On the inverter's input side, connect an MC for the following purposes:<br>To disconnect the inverter from the power supply at activation of a protective function or at malfunctioning of the driving system (emergency stop, etc.).<br>To prevent any accident due to an automatic restart at power restoration after an inverter stop made by a power failure.<br>To separate the inverter from the power supply to ensure safe maintenance and inspection work.<br>To use an MC to perform an emergency stop during operation, select the MC conforming to JEM 1038-AC-3 rated current for the inverter rated input current.   |
| The magnetic contactor on the inverter's output side is properly handled.                         | Switch the magnetic contactor between the inverter and motor only when both the inverter and motor are at a stop.  |
| When using a PM motor, a low-voltage manual contactor is installed on the inverter's output side. | A PM motor is a synchronous motor with high-performance magnets embedded inside. High-voltage is generated at the motor terminals while the motor is running even after the inverter power is turned OFF. In an application, such as fan and blower, where the motor is driven by the load, a low-voltage manual contactor must be connected on the inverter's output side, and wiring and inspection must be performed while the contactor is open. Otherwise you may get an electric shock.  |
| An EMI countermeasure is provided for the frequency setting signals.                              | If electromagnetic noise generated from the inverter causes the frequency setting signal to fluctuate and the motor rotation speed to be unstable when changing the motor speed with analog signals, the following countermeasures are effective:<br>Do not run the signal cables and power cables (inverter I/O cables) in parallel with each other and do not bundle them.<br>Run the signal cables as far away as possible from the power cables (inverter I/O cables).<br>Use shielded cables.<br>Install a data line filter to signal cable (example: ZCAT3035-1330 by TDK).  |
| A countermeasure is provided for an overload operation.   | When performing frequent starts/stops by the inverter, rise/fall in the temperature of the transistor element of the inverter will repeat due to a repeated flow of large current, shortening the life from thermal fatigue. Since thermal fatigue is related to the amount of current, the life can be increased by reducing current at locked condition, starting current, etc. Reducing current may extend the service life but may also cause torque shortage, which leads to a start failure. Adding a margin to the current can eliminate such a condition. For an induction motor, use an inverter of a higher capacity (up to two ranks). For a PM motor, use an inverter and PM motor of higher capacities. |
| The specifications and rating match the system requirements.                                      | Make sure that the specifications and rating match the system requirements.  |
| Countermeasures are taken against electrical corrosion on the motor bearing.                      | When a motor is driven by the inverter, axial voltage is generated on the motor shaft, which may cause electrical corrosion of the bearing in rare cases depending on the wiring, load, operating conditions of the motor or specific inverter settings (high carrier frequency). Contact your sales representative to take appropriate countermeasures for the motor. The following shows examples of countermeasures for the inverter.<br>Decrease the carrier frequency.<br>Provide a common mode choke <sup>*1</sup> on the output side of the inverter.   |

<sup>\*1</sup> Recommended common mode choke: FT-3KM F series FINEMET® common mode choke cores manufactured by Hitachi Metals, Ltd. FINEMET is a registered trademark of Hitachi Metals, Ltd.

# 5 BASIC OPERATION

This chapter explains the basic operation of this product.

Always read the instructions before use.

## 5.1 Operation panel

### 5.1.1 Components of the operation panel

#### Standard mode

The operation panel cannot be removed from the inverter.

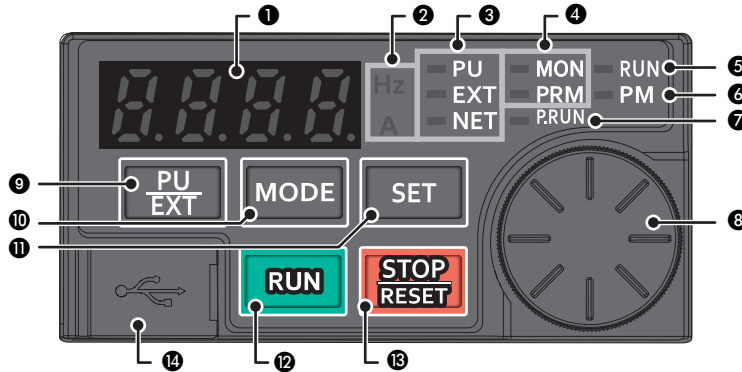

| No. | Component | Name                                  | Description  |
|-----|-----------|---------------------------------------|--|
| ①   |           | Monitor (4-digit LED)                 | Shows a numeric value (readout) of a monitor item such as the frequency or a parameter number.<br>(The monitor item can be changed according to the settings of <b>Pr.52</b> , <b>Pr.774</b> to <b>Pr.776</b> .)   |
| ②   |           | Unit indication                       | Hz: ON when the actual frequency is monitored.<br>(Blinks when the set frequency is monitored.)<br>A: ON when the current is monitored.<br>(Both "Hz" and "A" are OFF to indicate a value other than the frequency or the current.)  |
| ③   |           | Inverter operation mode LED indicator | PU: ON when the inverter is in the PU operation mode.<br>EXT: ON when the inverter is in the External operation mode.<br>(ON when the inverter in the initial setting is powered ON.)<br>NET: ON when the inverter is in the Network operation mode.<br>PU and EXT: ON when the inverter is in the External/PU combined operation mode 1 or 2.   |
| ④   |           | Operation panel mode LED indicator    | MON: ON or blinks only when the first, second, or third monitor is displayed.<br>PRM: ON when the operation panel is in the parameter setting mode.<br>The indicator blinks when the inverter is in the easy setting mode.   |
| ⑤   |           | Operating status indicator            | ON or blinks during inverter running.<br>ON: During forward rotation operation.<br>Blinks slowly (1.4-second cycle): During reverse rotation operation.<br>Blinks quickly (0.2-second cycle): Operation is disabled although the start command is given.*1   |
| ⑥   |           | Controlled motor type LED indicator   | ON when the inverter is set to control the PM motor.<br>The indicator blinks during test operation. The indicator is OFF when the inverter controls the induction motor.   |
| ⑦   |           | PLC function LED indicator            | ON when the PLC function of the inverter is valid.   |
| ⑧   |           | Setting dial                          | The setting dial of the Mitsubishi Electric inverters. Turn the setting dial to change the setting of frequency or parameter, etc.<br>Press the setting dial to perform the following operations:<br>• To display a set frequency on the LED display in the monitor mode.<br>(The monitor item shown on the display can be changed by using <b>Pr.992</b> .)<br>• To display the present setting during calibration. |
| ⑨   |           | PU/EXT key                            | Switches between the PU operation mode, the PUJOG operation mode, and the External operation mode.<br>The easy setting of the inverter operation mode is enabled by pressing this key simultaneously with the MODE key.<br>Also cancels the PU stop warning.   |
| ⑩   |           | MODE key                              | Switches the operation panel to a different mode.<br>The easy setting of the inverter operation mode is enabled by pressing this key simultaneously with the PU/EXT key.<br>Every key on the operation panel becomes inoperable by holding this key for 2 seconds. The key inoperable function is invalid when <b>Pr.161</b> = "0 (initial setting)". (refer to Instruction Manual (Function))                       |



| No. | Component | Name           | Description  |
|-----|-----------|----------------|--|
| 11  |           | SET key        | Confirms each selection. When this key is pressed during inverter operation, the monitor item changes. (The monitor item on each screen can be changed according to the settings of Pr.52, Pr.774 to Pr.776.)<br><div style="float: right; text-align: center;">                     Initial setting in the monitor mode<br/> </div> |
| 12  |           | RUN key        | Start command<br>The direction of motor rotation depends on the Pr.40 setting.   |
| 13  |           | STOP/RESET key | Stops the operation commands.<br>Used to reset the inverter when the protective function is activated.   |
| 14  |           | USB connector  | FR Configurator2 is available by USB connection.   |





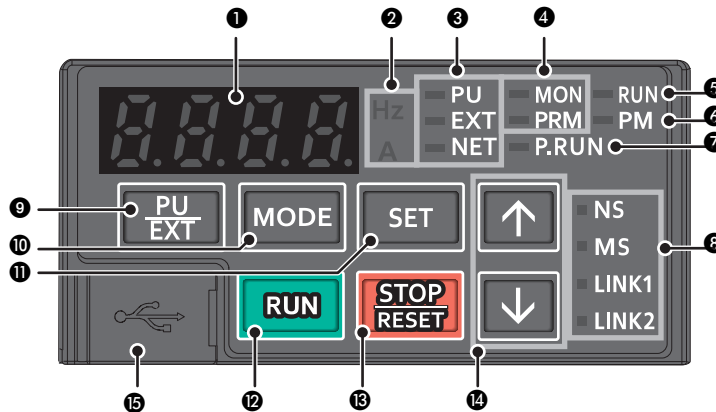

\*1 Situations such as when the MRS/X10 signal is input, during the automatic restart after instantaneous power failure, after auto tuning is complete, when "SE" (incorrect parameter setting) alarm occurs.

**Ethernet model and safety communication model**

The operation panel cannot be removed from the inverter.



| No. | Component | Name                                  | Description   |
|-----|-----------|---------------------------------------|---|
| 1   |           | Monitor (4-digit LED)                 | Shows a numeric value (readout) of a monitor item such as the frequency or a parameter number. (The monitor item can be changed according to the settings of Pr.52, Pr.774 to Pr.776.)  |
| 2   |           | Unit indication                       | Hz: ON when the actual frequency is monitored. (Blinks when the set frequency is monitored.)<br>A: ON when the current is monitored. (Both "Hz" and "A" are OFF to indicate a value other than the frequency or the current.)   |
| 3   |           | Inverter operation mode LED indicator | PU: ON when the inverter is in the PU operation mode.<br>EXT: ON when the inverter is in the External operation mode. (ON when the inverter in the initial setting is powered ON.)<br>NET: ON when the inverter is in the Network operation mode.<br>PU and EXT: ON when the inverter is in the External/PU combined operation mode 1 or 2. |
| 4   |           | Operation panel mode LED indicator    | MON: ON or blinks only when the first, second, or third monitor is displayed.<br>PRM: ON when the operation panel is in the parameter setting mode. The indicator blinks when the inverter is in the easy setting mode.   |
| 5   |           | Operating status indicator            | ON or blinks during inverter running.<br>ON: During forward rotation operation.<br>Blinks slowly (1.4-second cycle): During reverse rotation operation.<br>Blinks quickly (0.2-second cycle): Operation is disabled although the start command is given.*1  |
| 6   |           | Controlled motor type LED indicator   | ON when the inverter is set to control the PM motor. The indicator blinks during test operation. The indicator is OFF when the inverter controls the induction motor.   |
| 7   |           | PLC function LED indicator            | ON when the PLC function of the inverter is valid.  |
| 8   |           | Ethernet communication status         | Indicates the Ethernet communication status. For details, refer to the Instruction Manual (Communication).  |
| 9   |           | PU/EXT key                            | Switches between the PU operation mode, the PUJOG operation mode, and the External operation mode. The easy setting of the inverter operation mode is enabled by pressing this key simultaneously with the MODE key. Also cancels the PU stop warning.  |

| No. | Component   | Name           | Description  |
|-----|---|----------------|--|
| 10  |  | MODE key       | Switches the operation panel to a different mode.<br>The easy setting of the inverter operation mode is enabled by pressing this key simultaneously with the PU/EXT key.<br>Every key on the operation panel becomes inoperable by holding this key for 2 seconds. The key inoperable function is invalid when <b>Pr.161</b> = "0 (initial setting)". (refer to Instruction Manual (Function)) |
| 11  |  | SET key        | Confirms each selection.<br>When this key is pressed during inverter operation, the monitor item changes. (The monitor item on each screen can be changed according to the settings of <b>Pr.52, Pr.774 to Pr.776</b> .)   |
| 12  |  | RUN key        | Start command<br>The direction of motor rotation depends on the <b>Pr.40</b> setting.  |
| 13  |  | STOP/RESET key | Stops the operation commands.<br>Used to reset the inverter when the protective function is activated.   |
| 14  |  | UP/DOWN key    | Used to change the setting of frequency or parameter.  |
| 15  |  | USB connector  | FR Configurator2 is available by USB connection.   |

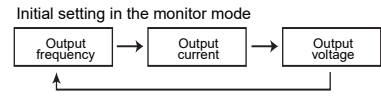

\*1 Situations such as when the MRS/X10 signal is input, during the automatic restart after instantaneous power failure, after auto tuning is complete, when "SE" (incorrect parameter setting) alarm occurs.



### 5.1.2 Basic operation of the operation panel

#### Basic operation (standard model)

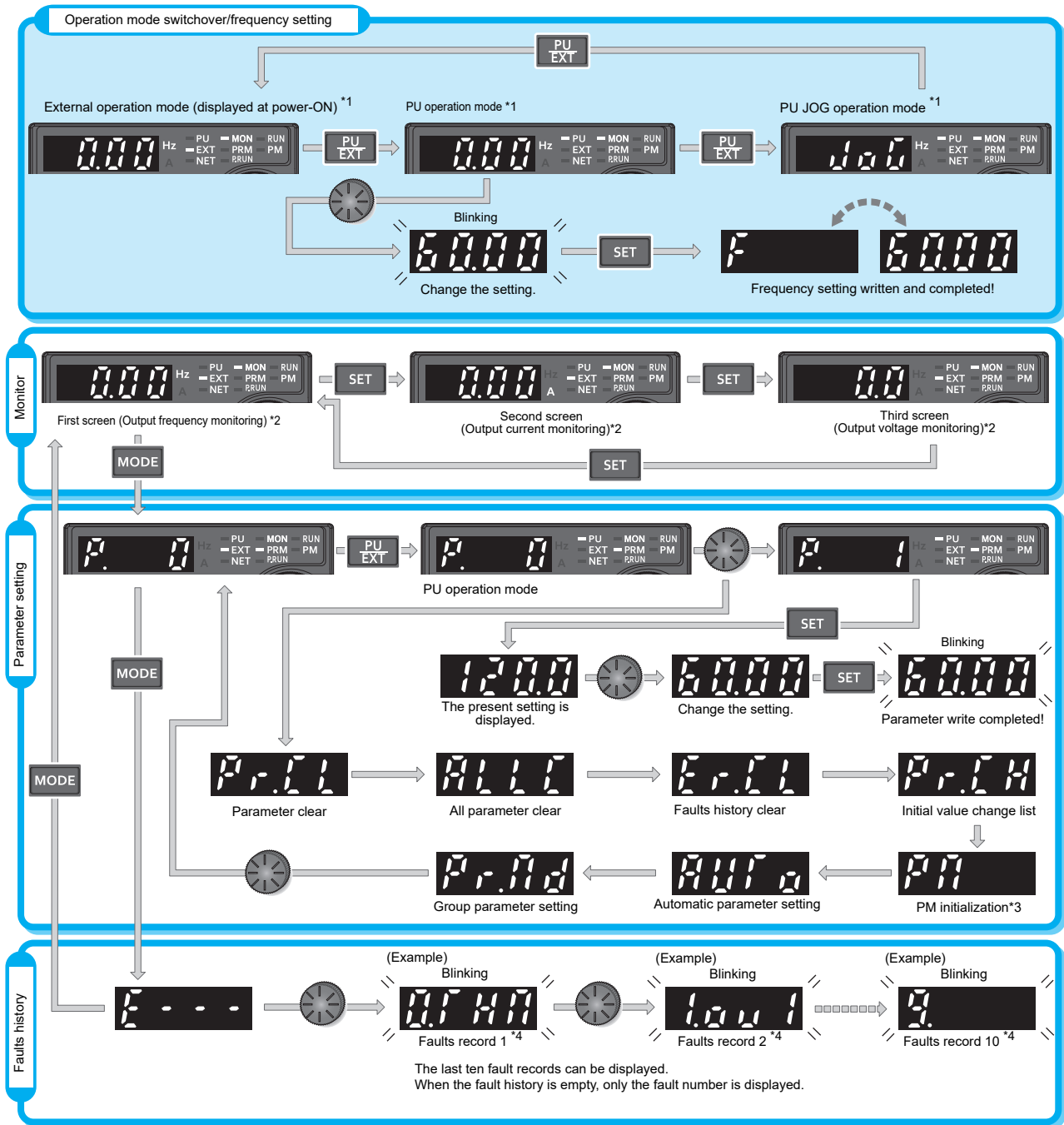

\*1 For the details of operation modes, refer to Instruction Manual (Function)

\*2 The monitor item can be changed. refer to Instruction Manual (Function)

\*3 Not displayed for the 575 V class.

\*4 For the details of the fault history, refer to the Instruction Manual (Maintenance).

Basic operation (Ethernet model and safety communication model)

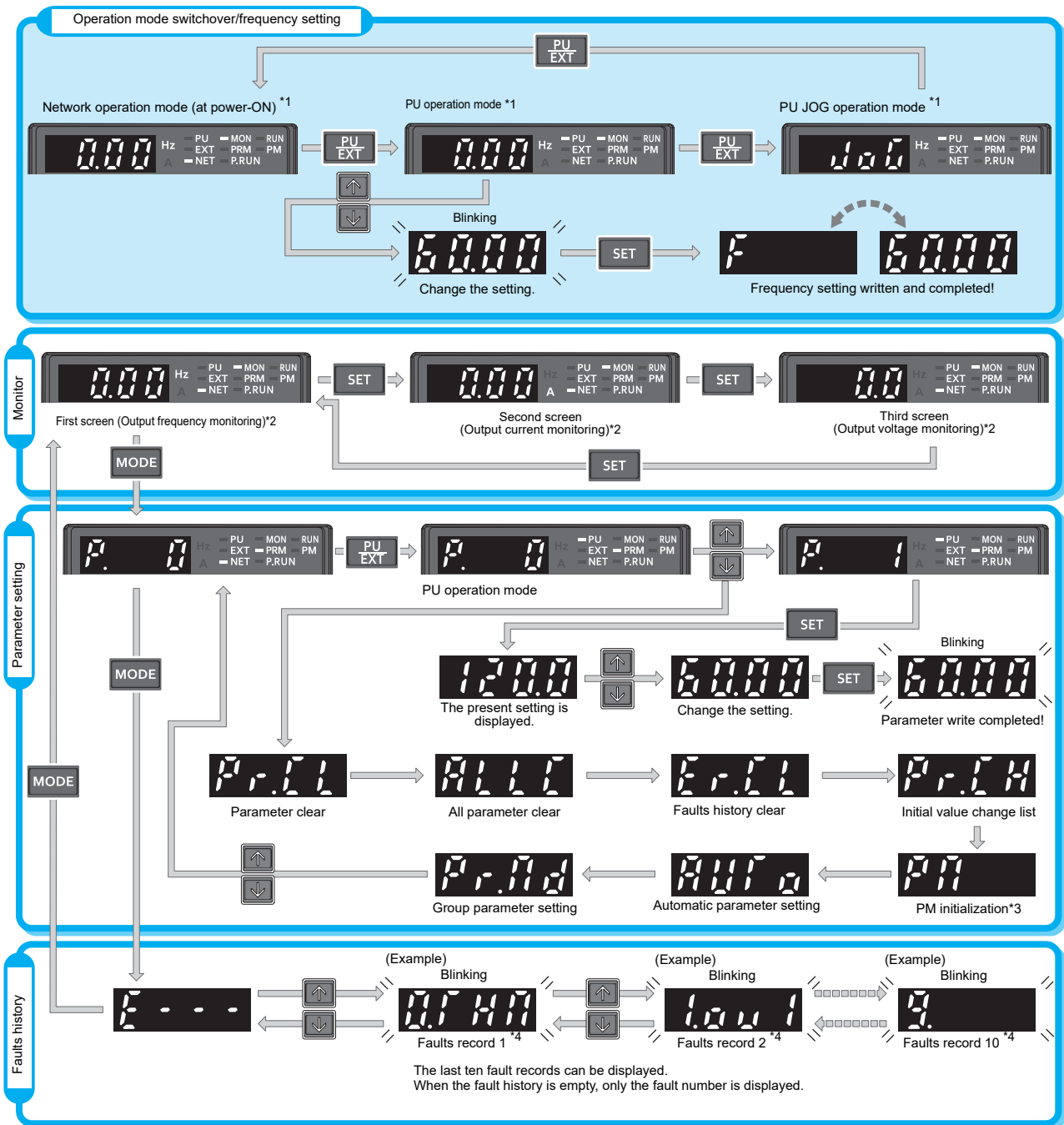

\*1 For the details of operation modes, refer to Instruction Manual (Function).

\*2 The monitor item can be changed. refer to Instruction Manual (Function).

\*3 Not displayed for the 575 V class.

\*4 For the details of the fault history, refer to the Instruction Manual (Maintenance).



## 6 PARAMETER LIST

For simple variable-speed operation of the inverter, the initial values of the parameters may be used as they are. Set the necessary parameters to meet the load and operational specifications. Parameter's setting, change and check can be made on the operation panel.

### CAUTION

- **Simple** indicates simple mode parameters. Use **Pr.160 User group read selection** to indicate the simple mode parameters only (initial setting is to indicate the extended mode parameters).
- The changing of the parameter settings may be restricted in some operating statuses. Use **Pr.77 Parameter write selection** to change the setting of the restriction.
- Refer to FR-E800 Function Manual for instruction codes for communication and availability of parameter copy, Parameter clear, and all clear.

### Notation

[E800]: Available for the standard model.

[E800-1]: Available for the FM type inverter (standard model).

[E800-4]: Available for the AM (50 Hz) type inverter (standard model).

[E800-5]: Available for the AM (60 Hz) type inverter (standard model).

[E800(-E)]: Available for the standard and Ethernet models.

[E800-(SC)E]: Available for the Ethernet model and the safety communication model.

[E800-SCE]: Available for the safety communication model.

[E800-(SC)EPA]: Available for the Protocol group A (Ethernet model / safety communication model).

[E800-(SC)EPB]: Available for the Protocol group B (Ethernet model / safety communication model).

[200/400 V class]: Available for the 200/400 V class inverters.

[575 V class]: Available for the 575 V class inverters.

[3-phase]: Available for the three-phase power input model.

### Parameter 0 to 99

| Parameter | Name   | Setting Range | Initial Value *1           |
|-----------|--|---------------|----------------------------|
| 0         | Torque boost <b>Simple</b>                       | 0% to 30%     | 6/5/4/3/<br>2%*2           |
| 1         | Maximum frequency <b>Simple</b>                  | 0 to 120 Hz   | 120 Hz                     |
| 2         | Minimum frequency <b>Simple</b>                  | 0 to 120 Hz   | 0 Hz                       |
| 3         | Base frequency <b>Simple</b>                     | 0 to 590 Hz   | Gr.1: 60 Hz<br>Gr.2: 50 Hz |
| 4         | Multi-speed setting (high speed) <b>Simple</b>   | 0 to 590 Hz   | Gr.1: 60 Hz<br>Gr.2: 50 Hz |
| 5         | Multi-speed setting (middle speed) <b>Simple</b> | 0 to 590 Hz   | 30 Hz                      |
| 6         | Multi-speed setting (low speed) <b>Simple</b>    | 0 to 590 Hz   | 10 Hz                      |
| 7*3       | Acceleration time <b>Simple</b>                  | 0 to 3600 s   | 5 s*2                      |
|           |  |               | 10 s*2                     |
|           |  |               | 15 s*2                     |
| 8*3       | Deceleration time <b>Simple</b>                  | 0 to 3600 s   | 5 s*2                      |
|           |  |               | 10 s*2                     |
|           |  |               | 15 s*2                     |

| Parameter | Name  | Setting Range           | Initial Value *1           |
|-----------|---|-------------------------|----------------------------|
| 9         | Electronic thermal O/L relay <b>Simple</b><br>Rated motor current <b>Simple</b> | 0 to 500 A              | Inverter rated current     |
| 10        | DC injection brake operation frequency  | 0 to 120 Hz             | 3 Hz                       |
| 11        | DC injection brake operation time   | 0 to 10 s, 8888         | 0.5 s                      |
| 12        | DC injection brake operation voltage  | 0% to 30%               | 6/4/2/1%*2                 |
| 13        | Starting frequency  | 0 to 60 Hz              | 0.5 Hz                     |
| 14        | Load pattern selection  | 0 to 3                  | 0                          |
| 15        | Jog frequency   | 0 to 590 Hz             | 5 Hz                       |
| 16*3      | Jog acceleration/ deceleration time   | 0 to 3600 s             | 0.5 s                      |
| 17        | MRS/X10 terminal input selection  | 0 to 5                  | 0                          |
| 18        | High speed maximum frequency  | 0 to 590 Hz             | 120 Hz                     |
| 19        | Base frequency voltage  | 0 to 1000 V, 8888, 9999 | Gr.1: 9999<br>Gr.2: 8888   |
| 20        | Acceleration/ deceleration reference frequency                                  | 1 to 590 Hz             | Gr.1: 60 Hz<br>Gr.2: 50 Hz |



| Parameter | Name   | Setting Range     | Initial Value *1   |
|-----------|--|-------------------|--------------------|
| 21        | Acceleration/ deceleration time increments                           | 0, 1              | 0                  |
| 22        | Stall prevention operation level (Torque limit level)                | 0% to 400%        | 150%               |
| 23        | Stall prevention operation level compensation factor at double speed | 0% to 200%, 9999  | 9999               |
| 24 to 27  | Multi-speed setting (speed 4 to speed 7)                             | 0 to 590 Hz, 9999 | 9999               |
| 29        | Acceleration/ deceleration pattern selection                         | 0 to 2            | 0                  |
| 30        | Regenerative function selection                                      | 0 to 2            | 0                  |
| 31        | Frequency jump 1A  | 0 to 590 Hz, 9999 | 9999               |
| 32        | Frequency jump 1B  | 0 to 590 Hz, 9999 | 9999               |
| 33        | Frequency jump 2A  | 0 to 590 Hz, 9999 | 9999               |
| 34        | Frequency jump 2B  | 0 to 590 Hz, 9999 | 9999               |
| 35        | Frequency jump 3A  | 0 to 590 Hz, 9999 | 9999               |
| 36        | Frequency jump 3B  | 0 to 590 Hz, 9999 | 9999               |
| 37*3      | Speed display  | 0.01 to 9998      | 1800               |
| 40        | RUN key rotation direction selection                                 | 0, 1              | 0                  |
| 41        | Up-to-frequency sensitivity  | 0% to 100%        | 10%                |
| 42        | Output frequency detection   | 0 to 590 Hz       | 6 Hz               |
| 43        | Output frequency detection for reverse rotation                      | 0 to 590 Hz, 9999 | 9999               |
| 44*3      | Second acceleration/ deceleration time                               | 0 to 3600 s       | 5 s <sup>*2</sup>  |
|           |  |                   | 10 s <sup>*2</sup> |
|           |  |                   | 15 s <sup>*2</sup> |
| 45*3      | Second deceleration time   | 0 to 3600 s, 9999 | 9999               |
| 46        | Second torque boost  | 0% to 30%, 9999   | 9999               |
| 47        | Second V/F (base frequency)  | 0 to 590 Hz, 9999 | 9999               |
| 48        | Second stall prevention operation level                              | 0% to 400%, 9999  | 9999               |
| 51        | Second electronic thermal O/L relay Rated second motor current       | 0 to 500 A, 9999  | 9999               |

| Parameter | Name  | Setting Range   | Initial Value *1           |
|-----------|---|---|----------------------------|
| 52        | Operation panel main monitor selection                  | [E800][E800-(SC)EPB]<br>0, 5 to 14, 17 to 20, 23 to 33, 35, 38, 40 to 42, 44, 45, 50 to 57, 61, 62, 64, 65, 67, 91, 97, 100 | 0                          |
|           |   | [E800-(SC)EPA]<br>0, 5 to 14, 17 to 20, 23 to 33, 35, 38, 40 to 42, 44, 45, 50 to 57, 61, 62, 64, 65, 67, 83, 91, 97, 100   |                            |
| 53        | Frequency / rotation speed unit switchover              | 0, 1, 4   | 0                          |
| 54        | FM terminal function selection [E800-1]                 | 1 to 3, 5 to 14, 17, 18, 21, 24, 32, 33, 50, 52, 53, 61, 62, 65, 67, 70, 97   | 1                          |
| 55*6      | Frequency monitoring reference                          | 0 to 590 Hz   | Gr.1: 60 Hz<br>Gr.2: 50 Hz |
| 56*6      | Current monitoring reference                            | 0 to 500 A  | Inverter rated current     |
| 57        | Restart coasting time                                   | 0, 0.1 to 30 s, 9999  | 9999                       |
| 58        | Restart cushion time                                    | 0 to 60 s   | 1 s                        |
| 59        | Remote function selection                               | 0 to 3, 11 to 13  | 0                          |
| 60        | Energy saving control selection                         | 0, 9  | 0                          |
| 61        | Reference current                                       | 0 to 500 A, 9999  | 9999                       |
| 62        | Reference value at acceleration                         | 0% to 400%, 9999  | 9999                       |
| 63        | Reference value at deceleration                         | 0% to 400%, 9999  | 9999                       |
| 65        | Retry selection   | 0 to 5  | 0                          |
| 66        | Stall prevention operation reduction starting frequency | 0 to 590 Hz   | Gr.1: 60 Hz<br>Gr.2: 50 Hz |
| 67        | Number of retries at fault occurrence                   | 0 to 10, 101 to 110   | 0                          |
| 68        | Retry waiting time                                      | 0.1 to 600 s  | 1 s                        |
| 69        | Retry count display erase                               | 0   | 0                          |
| 70        | Special regenerative brake duty                         | 0% to 100%  | 0%                         |
| 71        | Applied motor   | [200/400 V class]<br>0, 3, 5, 6, 10, 13, 15, 16, 20, 23, 30, 33, 40, 43, 50, 53, 70, 73, 1800, 1803, 8090, 8093, 9090, 9093 | 0                          |
|           |   | [575 V class]<br>0, 3, 5, 6, 10, 13, 15, 16, 30, 33, 8090, 8093, 9090, 9093   |                            |
| 72        | PWM frequency selection                                 | 0 to 15   | 1                          |
| 73        | Analog input selection                                  | 0, 1, 6, 10, 11, 16   | 1                          |

| Parameter | Name  | Setting Range  | Initial Value *1  |
|-----------|---|--|---|
| 74        | Input filter time constant  | 0 to 8   | 1   |
| 75        | Reset selection/<br>disconnected PU<br>detection/PU stop<br>selection | [E800(-E)]<br>0 to 3, 14 to 17<br>[E800-SCE]<br>0 to 3, 14 to 17,<br>10000 to 10003,<br>10014 to 10017 | [E800(-E)]<br>14<br>[E800-SCE]<br>10014   |
|           | Reset selection   | 0, 1   | 0   |
|           | Disconnected PU<br>detection [E800]                                   |  | 1   |
|           | PU stop selection   |  | [E800(-E)]<br>0<br>[E800-SCE]<br>10   |
| 77        | Parameter write<br>selection  | 0 to 2   | 0   |
| 78        | Reverse rotation<br>prevention selection                              | 0 to 2   | 0   |
| 79        | Operation mode<br>selection <a href="#">Simple</a>                    | 0 to 4, 6, 7   | 0   |
| 80        | Motor capacity  | 0.1 to 30 kW,<br>9999  | 9999  |
| 81        | Number of motor<br>poles  | 2, 4, 6, 8, 10,<br>12, 9999  | 9999  |
| 82        | Motor excitation<br>current   | 0 to 500 A, 9999   | 9999  |
| 83        | Rated motor voltage   | 0 to 1000 V  | [200 V<br>class]<br>200 V<br>[400 V<br>class]<br>400 V<br>[575 V<br>class]<br>575 V |
| 84        | Rated motor<br>frequency  | 10 to 400 Hz,<br>9999  | 9999  |
| 89        | Speed control gain<br>(Advanced magnetic<br>flux vector)              | 0% to 200%,<br>9999  | 9999  |
| 90        | Motor constant (R1)   | 0 to 50 Ω, 9999  | 9999  |
| 91        | Motor constant (R2)   | 0 to 50 Ω, 9999  | 9999  |
| 92        | Motor constant (L1)/<br>d-axis inductance<br>(Ld)                     | 0 to 6000 mH,<br>9999  | 9999  |
| 93        | Motor constant (L2)/<br>q-axis inductance<br>(Lq)                     | 0 to 6000 mH,<br>9999  | 9999  |
| 94        | Motor constant (X)  | 0% to 100%,<br>9999  | 9999  |
| 95        | Online auto tuning<br>selection                                       | 0, 1   | 0   |
| 96        | Auto tuning setting/<br>status  | 0, 1, 11   | 0   |

## Parameter 100 to 99

| Parameter | Name   | Setting Range                          | Initial Value *1 |
|-----------|--|--|------------------|
| 117       | PU communication<br>station number<br>[E800] | 0 to 31                                | 0                |
| 118       | PU communication<br>speed [E800]             | 48, 96, 192,<br>384, 576, 768,<br>1152 | 192              |

| Parameter | Name   | Setting Range  | Initial Value *1           |
|-----------|--|--|----------------------------|
| 119       | PU communication<br>stop bit length / data<br>length [E800]              | 0, 1, 10, 11   | 1                          |
|           | PU communication<br>data length [E800]                                   | 0, 1   | 0                          |
|           | PU communication<br>stop bit length [E800]                               | 0, 1   | 1                          |
| 120       | PU communication<br>parity check [E800]                                  | 0 to 2   | 2                          |
| 121       | PU communication<br>retry count [E800]                                   | 0 to 10, 9999  | 1                          |
| 122       | PU communication<br>check time interval<br>[E800]                        | 0, 0.1 to 999.8 s,<br>9999   | 0                          |
| 123       | PU communication<br>waiting time setting<br>[E800]                       | 0 to 150 ms,<br>9999   | 9999                       |
| 124       | PU communication<br>CR/LF selection<br>[E800]                            | 0 to 2   | 1                          |
| 125       | Terminal 2 frequency<br>setting gain<br>frequency <a href="#">Simple</a> | 0 to 590 Hz  | Gr.1: 60 Hz<br>Gr.2: 50 Hz |
| 126       | Terminal 4 frequency<br>setting gain<br>frequency <a href="#">Simple</a> | 0 to 590 Hz  | Gr.1: 60 Hz<br>Gr.2: 50 Hz |
| 127       | PID control<br>automatic<br>switchover<br>frequency                      | 0 to 590 Hz,<br>9999   | 9999                       |
| 128       | PID action selection   | 0, 20, 21, 40 to<br>43, 50, 51, 60,<br>61, 1000, 1001,<br>1010, 1011,<br>2000, 2001,<br>2010, 2011 | 0                          |
| 129       | PID proportional<br>band   | 0.1% to 1000%,<br>9999   | 100%                       |
| 130       | PID integral time  | 0.1 to 3600 s,<br>9999   | 1 s                        |
| 131       | PID upper limit  | 0% to 100%,<br>9999  | 9999                       |
| 132       | PID lower limit  | 0% to 100%,<br>9999  | 9999                       |
| 133       | PID action set point   | 0% to 100%,<br>9999  | 9999                       |
| 134       | PID differential time  | 0.01 to 10 s,<br>9999  | 9999                       |
| 145       | PU display language<br>selection [E800]                                  | 0 to 7   | —                          |
| 147       | Acceleration/<br>deceleration time<br>switching frequency                | 0 to 590 Hz,<br>9999   | 9999                       |
| 150       | Output current<br>detection level  | 0% to 400%   | 150%                       |
| 151       | Output current<br>detection signal<br>delay time                         | 0 to 10 s  | 0 s                        |
| 152       | Zero current<br>detection level  | 0% to 400%   | 5%                         |
| 153       | Zero current<br>detection time   | 0 to 10 s  | 0.5 s                      |
| 154       | Voltage reduction<br>selection during stall<br>prevention operation      | 1, 11  | 1                          |
| 156       | Stall prevention<br>operation selection                                  | 0 to 31, 100,<br>101   | 0                          |



| Parameter | Name  | Setting Range  | Initial Value*1                      |
|-----------|---|--|--------------------------------------|
| 157       | OL signal output timer  | 0 to 25 s, 9999  | 0 s                                  |
| 158       | AM terminal function selection [E800-4][E800-5]               | 1 to 3, 5 to 14, 17, 18, 21, 24, 32, 33, 50, 52 to 54, 61, 62, 65, 67, 70, 91, 97  | 1                                    |
| 160       | User group read selection <i>Simple</i>                       | 0, 1, 9999   | 0                                    |
| 161       | Frequency setting/ key lock operation selection               | 0, 1, 10, 11   | 0                                    |
| 162       | Automatic restart after instantaneous power failure selection | 0, 1, 10, 11   | 0                                    |
| 165       | Stall prevention operation level for restart                  | 0% to 400%   | 150%                                 |
| 166       | Output current detection signal retention time                | 0 to 10 s, 9999  | 0.1 s                                |
| 167       | Output current detection operation selection                  | 0, 1, 10, 11   | 0                                    |
| 168       | Parameter for manufacturer setting. Do not set.               |  |                                      |
| 169       |   |  |                                      |
| 170       | Watt-hour meter clear   | 0, 10, 9999  | 9999                                 |
| 171       | Operation hour meter clear                                    | 0, 9999  | 9999                                 |
| 172       | User group registered display/ batch clear                    | 9999, (0 to 16)  | 0                                    |
| 173       | User group registration                                       | 0 to 1999, 9999  | 9999                                 |
| 174       | User group clear  | 0 to 1999, 9999  | 9999                                 |
| 178       | STF/DI0 terminal function selection                           | 0 to 5, 7, 8, 10, 12 to 16, 18, 23 to 27, 30, 37, 42, 43, 46, 47, 50, 51, 60, 62, 65 to 67, 72, 74, 76, 87 to 89, 92, 9999       | 60                                   |
| 179       | STR/DI1 terminal function selection                           | 0 to 5, 7, 8, 10, 12 to 16, 18, 23 to 27, 30, 37, 42, 43, 46, 47, 50, 51, 61, 62, 65 to 67, 72, 74, 76, 87 to 89, 92, 9999       | 61                                   |
| 180       | RL terminal function selection                                | [E800]<br>0 to 5, 7, 8, 10, 12 to 16, 18, 23 to 27, 30, 37, 42, 43, 46, 47, 50, 51, 62, 65 to 67, 72, 74, 76, 87 to 89, 92, 9999 | 0                                    |
| 181       | RM terminal function selection                                | [E800-4][E800-5]   | 1                                    |
| 182       | RH terminal function selection                                | [E800-4][E800-5]   | 2                                    |
| 183       | MRS terminal function selection                               | [E800-4][E800-5]   | 24                                   |
| 184       | RES terminal function selection                               | [E800-4][E800-5]   | [E800]<br>62<br>[E800-(SC)E]<br>9999 |

| Parameter | Name                            | Setting Range   | Initial Value*1 |
|-----------|---------------------------------|---|-----------------|
| 185       | NET X1 input selection          | 0 to 4, 8, 13 to 15, 18, 23, 24, 26, 27, 30, 37, 42, 43, 46, 47, 50, 51, 72, 74, 76, 87 to 89, 92, 9999   | 9999            |
| 186       | NET X2 input selection          |   |                 |
| 187       | NET X3 input selection          |   |                 |
| 188       | NET X4 input selection          |   |                 |
| 189       | NET X5 input selection          |   |                 |
| 190       | RUN terminal function selection | 0, 1, 3, 4, 7, 8, 11 to 16, 20, 24 to 26, 30 to 36, 38 to 41, 44 to 48, 56, 57, 60 to 64, 70, 80, 81, 84, 90 to 93, 95, 96, 98 to 101, 103, 104, 107, 108, 111 to 116, 120, 124 to 126, 130 to 136, 138 to 141, 144 to 148, 156, 157, 160 to 164, 170, 180, 181, 184, 190 to 193, 195, 196, 198, 199, 206, 211 to 213, 242 [E800-(SC)E], 306, 311 to 313, 342 [E800-(SC)E], 9999                                    | 0               |
| 191       | FU terminal function selection  | 0, 1, 3, 4, 7, 8, 11 to 16, 20, 24 to 26, 30 to 36, 38 to 41, 44 to 48, 56, 57, 60 to 64, 70, 80, 81, 82 [E800-(SC)EPA], 84, 90, 91, 95, 96, 98 to 101, 103, 104, 107, 108, 111 to 116, 120, 124 to 126, 130 to 136, 138 to 141, 144 to 148, 156, 157, 160 to 164, 170, 180, 181, 182 [E800-(SC)EPA], 184, 190, 191, 195, 196, 198, 199, 206, 211 to 213, 242 [E800-(SC)E], 306, 311 to 313, 342 [E800-(SC)E], 9999 | 4               |
| 192       | ABC terminal function selection | 0, 1, 3, 4, 7, 8, 11 to 16, 20, 24 to 26, 30 to 36, 38 to 41, 44 to 48, 56, 57, 60 to 64, 70, 80, 81, 82 [E800-(SC)EPA], 84, 90, 91, 95, 96, 98 to 101, 103, 104, 107, 108, 111 to 116, 120, 124 to 126, 130 to 136, 138 to 141, 144 to 148, 156, 157, 160 to 164, 170, 180, 181, 182 [E800-(SC)EPA], 184, 190, 191, 195, 196, 198, 199, 206, 211 to 213, 242 [E800-(SC)E], 306, 311 to 313, 342 [E800-(SC)E], 9999 | 99              |

| Parameter | Name                    | Setting Range   | Initial Value *1 |
|-----------|-------------------------|---|------------------|
| 193       | NET Y1 output selection | 0, 1, 3, 4, 7, 8, 11 to 16, 20, 24 to 26, 30 to 36, 38 to 41, 44 to 48, 56, 57, 60 to 64, 70, 80, 81, 84, 90 to 93, 95, 98 to 101, 103, 104, 107, 108, 111 to 116, 120, 124 to 126, 130 to 136, 138 to 141, 144 to 148, 156, 157, 160 to 164, 170, 180, 181, 184, 190 to 193, 195, 198, 199, 206, 211 to 213, 242 [E800-(SC)E], 306, 311 to 313, 342 [E800-(SC)E], 9999 | 9999             |
| 194       | NET Y2 output selection |   | 9999             |
| 195       | NET Y3 output selection |   | 9999             |
| 196       | NET Y4 output selection |   | 9999             |
| 198       | Display corrosion level | (1 to 3)  | 1                |

## Parameter 200 to 299

| Parameter  | Name  | Setting Range                          | Initial Value *1   |
|------------|---|--|--------------------|
| 232 to 239 | Multi-speed setting (speed 8 to speed 15)         | 0 to 590 Hz, 9999                      | 9999               |
| 240        | Soft-PWM operation selection                      | 0, 1                                   | 1                  |
| 241        | Analog input display unit switchover              | 0, 1                                   | 0                  |
| 244        | Cooling fan operation selection                   | 0, 1                                   | 1                  |
| 245        | Rated slip  | 0% to 50%, 9999                        | 9999               |
| 246        | Slip compensation time constant                   | 0.01 to 10 s                           | 0.5 s              |
| 247        | Constant output range slip compensation selection | 0, 9999                                | 9999               |
| 249        | Earth (ground) fault detection at start           | 0, 1                                   | Gr.1: 0<br>Gr.2: 1 |
| 250        | Stop selection                                    | 0 to 100 s, 1000 to 1100 s, 8888, 9999 | 9999               |
| 251        | Output phase loss protection selection            | 0, 1                                   | 1                  |
| 255        | Life alarm status display                         | (0 to 879)                             | 0                  |
| 256        | Inrush current limit circuit life display         | (0% to 100%)                           | 100%               |
| 257        | Control circuit capacitor life display            | (0% to 100%)                           | 100%               |
| 258        | Main circuit capacitor life display               | (0% to 100%)                           | 100%               |
| 259        | Main circuit capacitor life measuring             | 0, 1                                   | 0                  |
| 260        | PWM frequency automatic switchover                | 0, 10                                  | 10                 |
| 261        | Power failure stop selection                      | 0 to 2                                 | 0                  |

| Parameter | Name  | Setting Range                     | Initial Value *1 |
|-----------|---|-----------------------------------|------------------|
| 267       | Terminal 4 input selection  | 0 to 2                            | 0                |
| 268       | Monitor decimal digits selection  | 0, 1, 9999                        | 9999             |
| 269       | Parameter for manufacturer setting. Do not set.                             |                                   |                  |
| 270       | Stop-on-contact control selection   | 0, 1, 11                          | 0                |
| 275       | Stop-on contact excitation current low-speed scaling factor                 | 0% to 300%, 9999                  | 9999             |
| 276       | PWM carrier frequency at stop-on contact                                    | 0 to 9, 9999                      | 9999             |
| 277       | Stall prevention operation current switchover                               | 0, 1                              | 0                |
| 278       | Brake opening frequency   | 0 to 30 Hz                        | 3 Hz             |
| 279       | Brake opening current   | 0% to 400%                        | 130%             |
| 280       | Brake opening current detection time  | 0 to 2 s                          | 0.3 s            |
| 281       | Brake operation time at start   | 0 to 5 s                          | 0.3 s            |
| 282       | Brake operation frequency   | 0 to 30 Hz                        | 6 Hz             |
| 283       | Brake operation time at stop  | 0 to 5 s                          | 0.3 s            |
| 284       | Deceleration detection function selection                                   | 0, 1                              | 0                |
| 285       | Overspeed detection frequency<br>Speed deviation excess detection frequency | 0 to 30 Hz, 9999                  | 9999             |
| 286       | Droop gain  | 0% to 100%                        | 0%               |
| 287       | Droop filter time constant  | 0 to 1 s                          | 0.3 s            |
| 289       | Inverter output terminal filter   | 5 to 50 ms, 9999                  | 9999             |
| 290       | Monitor negative output selection   | 0, 1, 4, 5, 8, 9, 12, 13          | 0                |
| 292       | Automatic acceleration/ deceleration  | 0, 1, 7, 8, 11                    | 0                |
| 293       | Acceleration/ deceleration separate selection                               | 0 to 2                            | 0                |
| 295       | Frequency change increment amount setting [E800]                            | 0, 0.01, 0.1, 1, 10,              | 0                |
| 296       | Password lock level   | 0 to 6, 99, 100 to 106, 199, 9999 | 9999             |
| 297       | Password lock/ unlock   | (0 to 5), 1000 to 9998, 9999      | 9999             |
| 298       | Frequency search gain   | 0 to 32767, 9999                  | 9999             |
| 299       | Rotation direction detection selection at restarting                        | 0, 1, 9999                        | 0                |



Parameter 300 to 399

| Parameter | Name   | Setting Range  | Initial Value *1                  |
|-----------|--|--|-----------------------------------|
| 313*7     | DO0 output selection                                   | 0, 1, 3, 4, 7, 8, 11 to 16, 20, 24 to 26, 30 to 36, 38 to 41, 44 to 48, 56, 57, 60 to 64, 70, 80, 81, 84, 90 to 93, 95, 96, 98 to 101, 103, 104, 107, 108, 111 to 116, 120, 124 to 126, 130 to 136, 138 to 141, 144 to 148, 156, 157, 160 to 164, 170, 180, 181, 184, 190 to 193, 195, 196, 198, 199, 206, 211 to 213, 242 [E800-(SC)E], 306, 311 to 313, 342 [E800-(SC)E], 9999 | 9999                              |
| 314*7     | DO1 output selection                                   |  | 9999                              |
| 315*7     | DO2 output selection                                   |  | 9999                              |
| 316*7     | DO3 output selection                                   |  | 9999                              |
| 317*7     | DO4 output selection                                   |  | 9999                              |
| 318*7     | DO5 output selection                                   |  | 9999                              |
| 319*7     | DO6 output selection                                   |  | 9999                              |
| 320*7     | RA1 output selection                                   | 0, 1, 3, 4, 7, 8, 11 to 16, 20, 24 to 26, 30 to 36, 38 to 41, 44 to 48, 56, 57, 60 to 64, 70, 80, 81, 84, 90, 91, 95, 96, 98, 99, 206, 211 to 213, 242 [E800-(SC)E], 9999  | 0                                 |
| 321*7     | RA2 output selection                                   |  | 1                                 |
| 322*7     | RA3 output selection                                   |  | 4                                 |
| 338       | Communication operation command source                 | 0, 1   | 0                                 |
| 339       | Communication speed command source                     | 0 to 2   | 0                                 |
| 340       | Communication startup mode selection                   | 0, 1, 10   | [E800]<br>0<br>[E800-(SC)E]<br>10 |
| 342       | Communication EEPROM write selection                   | 0, 1   | 0                                 |
| 343       | Communication error count [E800]                       | (0 to 999)   | 0                                 |
| 349*8     | Communication reset selection                          | 0, 1   | 0                                 |
| 359*4     | Encoder rotation direction                             | 100, 101   | 101                               |
| 367*4     | Speed feedback range                                   | 0 to 590 Hz, 9999  | 9999                              |
| 368*4     | Feedback gain  | 0 to 100   | 1                                 |
| 369*4     | Number of encoder pulses                               | 2 to 4096  | 1024                              |
| 374       | Overspeed detection level                              | 0 to 590 Hz, 9999  | 9999                              |
| 375       | Faulty acceleration rate detection level               | 0 to 400 Hz, 9999  | 9999                              |
| 376*4     | Encoder signal loss detection enable/disable selection | 0, 1   | 0                                 |
| 390       | % setting reference frequency [E800-(SC)EPA]           | 1 to 590 Hz  | Gr.1: 60 Hz<br>Gr.2: —            |

Parameter 400 to 499

| Parameter | Name   | Setting Range  | Initial Value *1   |
|-----------|--|--|--------------------|
| 414       | PLC function operation selection                                       | 0 to 2, 11, 12   | 0                  |
| 415       | Inverter operation lock mode setting                                   | 0, 1   | 0                  |
| 420       | Command pulse scaling factor numerator (electronic gear numerator)     | 1 to 32767   | 1                  |
| 421       | Command pulse multiplication denominator (electronic gear denominator) | 1 to 32767   | 1                  |
| 422       | Position control gain  | 0 to 150 s <sup>-1</sup>   | 10 s <sup>-1</sup> |
| 423       | Position feed forward gain   | 0% to 100%   | 0%                 |
| 425       | Position feed forward command filter                                   | 0 to 5 s   | 0 s                |
| 426       | In-position width  | 0 to 32767 pulses  | 100 pulses         |
| 427       | Excessive level error  | 0 to 400k pulses, 9999   | 40k pulses         |
| 430       | Pulse monitor selection  | 0 to 5, 100 to 105, 1000 to 1005, 1100 to 1105, 8888, 9999   | 9999               |
| 442       | Default gateway address 1 [E800-(SC)E]                                 | 0 to 255   | 0                  |
| 443       | Default gateway address 2 [E800-(SC)E]                                 |  |                    |
| 444       | Default gateway address 3 [E800-(SC)E]                                 |  |                    |
| 445       | Default gateway address 4 [E800-(SC)E]                                 |  |                    |
| 446       | Model position control gain  | 0 to 150 s <sup>-1</sup>   | 25 s <sup>-1</sup> |
| 450       | Second applied motor   | [200/400 V class]<br>0, 3, 5, 6, 10, 13, 15, 16, 20, 23, 30, 33, 40, 43, 50, 53, 70, 73, 1800, 1803, 8090, 8093, 9090, 9093, 9999<br>[575 V class]<br>0, 3, 5, 6, 10, 13, 15, 16, 30, 33, 8090, 8093, 9090, 9093, 9999 | 9999               |
| 451       | Second motor control method selection                                  | 10 to 12, 20, 40, 9999   | 9999               |
| 453       | Second motor capacity  | 0.1 to 30 kW, 9999   | 9999               |
| 454       | Number of second motor poles   | 2, 4, 6, 8, 10, 12, 9999   | 9999               |
| 455       | Second motor excitation current  | 0 to 500 A, 9999   | 9999               |

| Parameter | Name   | Setting Range       | Initial Value *1   |
|-----------|--|---------------------|--|
| 456       | Rated second motor voltage                             | 0 to 1000 V         | [200 V class]<br>200 V<br>[400 V class]<br>400 V<br>[575 V class]<br>575 V |
| 457       | Rated second motor frequency                           | 10 to 400 Hz, 9999  | 9999   |
| 458       | Second motor constant (R1)                             | 0 to 50 Ω, 9999     | 9999   |
| 459       | Second motor constant (R2)                             | 0 to 50 Ω, 9999     | 9999   |
| 460       | Second motor constant (L1) / d-axis inductance (Ld)    | 0 to 6000 mH, 9999  | 9999   |
| 461       | Second motor constant (L2) / q-axis inductance (Lq)    | 0 to 6000 mH, 9999  | 9999   |
| 462       | Second motor constant (X)                              | 0% to 100%, 9999    | 9999   |
| 463       | Second motor auto tuning setting/status                | 0, 1, 11            | 0  |
| 464       | Digital position control sudden stop deceleration time | 0.01 to 360 s       | 0.01 s   |
| 465       | First target position lower 4 digits                   | 0 to 9999           | 0  |
| 466       | First target position upper 4 digits                   | 0 to 9999           | 0  |
| 467       | Second target position lower 4 digits                  | 0 to 9999           | 0  |
| 468       | Second target position upper 4 digits                  | 0 to 9999           | 0  |
| 469       | Third target position lower 4 digits                   | 0 to 9999           | 0  |
| 470       | Third target position upper digits                     | 0 to 9999           | 0  |
| 471       | Fourth target position lower digits                    | 0 to 9999           | 0  |
| 472       | Fourth target position upper 4 digits                  | 0 to 9999           | 0  |
| 473       | Fifth target position lower 4 digits                   | 0 to 9999           | 0  |
| 474       | Fifth target position upper 4 digits                   | 0 to 9999           | 0  |
| 475       | Sixth target position lower 4 digits                   | 0 to 9999           | 0  |
| 476       | Sixth target position upper digits                     | 0 to 9999           | 0  |
| 477       | Seventh target position lower 4 digits                 | 0 to 9999           | 0  |
| 478       | Seventh target position upper 4 digits                 | 0 to 9999           | 0  |
| 495       | Remote output selection                                | 0, 1, 10, 11        | 0  |
| 496       | Remote output data 1                                   | 0 to 4095           | 0  |
| 497       | Remote output data 2                                   | 0 to 4095           | 0  |
| 498       | PLC function flash memory clear                        | 0, 9696 (0 to 9999) | 0  |

## Parameter 500 to 599

| Parameter         | Name  | Setting Range  | Initial Value *1           |
|-------------------|---|--|----------------------------|
| 502               | Stop mode selection at communication error                    | 0 to 2, 6  | 0                          |
| 503               | Maintenance timer   | 0 (1 to 9998)  | 0                          |
| 504               | Maintenance timer warning output set time                     | 0 to 9998, 9999                                      | 9999                       |
| 505               | Speed setting reference                                       | 1 to 590 Hz  | Gr.1: 60 Hz<br>Gr.2: 50 Hz |
| 506               | Display estimated main circuit capacitor residual life        | (0% to 100%)   | 100%                       |
| 507               | Display ABC relay contact life                                | 0% to 100%   | 100%                       |
| 509               | Display power cycle life                                      | (0% to 100%)   | 100%                       |
| 510               | Rough match output range                                      | 0 to 32767   | 0                          |
| 511               | Home position return shifting speed                           | 0 to 400 Hz  | 0.5 Hz                     |
| 538               | Current position retention selection                          | 1, 2, 11, 12, 9999                                   | 9999                       |
| 541 <sup>*8</sup> | Frequency command sign selection                              | 0, 1   | 0                          |
| 544 <sup>*8</sup> | CC-Link extended setting                                      | 0, 1, 12, 14, 18, 38, 100, 112, 114, 118, 138        | 0                          |
| 547               | USB communication station number                              | 0 to 31  | 0                          |
| 548               | USB communication check time interval                         | 0 to 999.8 s, 9999                                   | 9999                       |
| 549               | Protocol selection  | 0, 1   | 0                          |
| 550               | NET mode operation command source selection                   | [E800]<br>0, 2, 9999<br>[E800-(SC)E]<br>0, 5, 9999   | 9999                       |
| 551               | PU mode operation command source selection                    | [E800]<br>2 to 4, 9999<br>[E800-(SC)E]<br>3, 4, 9999 | 9999                       |
| 552               | Frequency jump range  | 0 to 30 Hz, 9999                                     | 9999                       |
| 553               | PID deviation limit   | 0% to 100%, 9999                                     | 9999                       |
| 554               | PID signal operation selection                                | 0 to 3, 10 to 13                                     | 0                          |
| 555               | Current average time  | 0.1 to 1 s   | 1 s                        |
| 556               | Data output mask time   | 0 to 20 s  | 0 s                        |
| 557               | Current average value monitor signal output reference current | 0 to 500 A   | Inverter rated current     |
| 560               | Second frequency search gain                                  | 0 to 32767, 9999                                     | 9999                       |
| 561               | PTC thermistor protection level                               | 0.5 to 30 kΩ, 9999                                   | 9999                       |
| 563               | Energization time carrying-over times                         | (0 to 65535)   | 0                          |
| 564               | Operating time carrying-over times                            | (0 to 65535)   | 0                          |
| 569               | Second motor speed control gain                               | 0% to 200%, 9999                                     | 9999                       |



| Parameter | Name  | Setting Range     | Initial Value *1 |
|-----------|---|-------------------|------------------|
| 570       | Multiple rating setting [3-phase]                 | 1, 2              | 2                |
| 571       | Holding time at a start                           | 0 to 10 s, 9999   | 9999             |
| 574       | Second motor online auto tuning                   | 0, 1              | 0                |
| 575       | Output interruption detection time                | 0 to 3600 s, 9999 | 1 s              |
| 576       | Output interruption detection level               | 0 to 590 Hz       | 0 Hz             |
| 577       | Output interruption cancel level                  | 900% to 1100%     | 1000%            |
| 592       | Traverse function selection                       | 0 to 2            | 0                |
| 593       | Maximum amplitude amount                          | 0% to 25%         | 10%              |
| 594       | Amplitude compensation amount during deceleration | 0% to 50%         | 10%              |
| 595       | Amplitude compensation amount during acceleration | 0% to 50%         | 10%              |
| 596       | Amplitude acceleration time                       | 0.1 to 3600 s     | 5 s              |
| 597       | Amplitude deceleration time                       | 0.1 to 3600 s     | 5 s              |

Parameter 600 to 699

| Parameter | Name   | Setting Range      | Initial Value *1 |
|-----------|--|--------------------|------------------|
| 600       | First free thermal reduction frequency 1                 | 0 to 590 Hz, 9999  | 9999             |
| 601       | First free thermal reduction ratio 1                     | 1% to 100%         | 100%             |
| 602       | First free thermal reduction frequency 2                 | 0 to 590 Hz, 9999  | 9999             |
| 603       | First free thermal reduction ratio 2                     | 1% to 100%         | 100%             |
| 604       | First free thermal reduction frequency 3                 | 0 to 590 Hz, 9999  | 9999             |
| 607       | Motor permissible load level                             | 110% to 250%       | 150%             |
| 608       | Second motor permissible load level                      | 110% to 250%, 9999 | 9999             |
| 609       | PID set point/ deviation input selection                 | 2 to 5             | 2                |
| 610       | PID measured value input selection                       | 2 to 5             | 3                |
| 611       | Acceleration time at a restart                           | 0 to 3600 s, 9999  | 9999             |
| 631       | Inverter output fault detection enable/disable selection | 0, 1               | 0                |
| 639       | Brake opening current selection                          | 0, 1               | 0                |
| 640       | Brake operation frequency selection                      | 0, 1               | 0                |

| Parameter | Name   | Setting Range     | Initial Value *1 |
|-----------|--|-------------------|------------------|
| 653       | Speed smoothing control  | 0% to 200%        | 0%               |
| 654       | Speed smoothing cutoff frequency                                   | 0 to 120 Hz       | 20 Hz            |
| 660       | Increased magnetic excitation deceleration operation selection     | 0, 1              | 0                |
| 661       | Magnetic excitation increase rate                                  | 0% to 40%, 9999   | 9999             |
| 662       | Increased magnetic excitation current level                        | 0% to 200%        | 100%             |
| 665       | Regeneration avoidance frequency gain                              | 0% to 200%        | 100%             |
| 673       | SF-PR slip amount adjustment operation selection [200/400 V class] | 2, 4, 6, 9999     | 9999             |
| 674       | SF-PR slip amount adjustment gain [200/400 V class]                | 0% to 500%        | 100%             |
| 675       | User parameter auto storage function selection                     | 1, 9999           | 9999             |
| 690       | Deceleration check time  | 0 to 3600 s, 9999 | 1 s              |
| 692       | Second free thermal reduction frequency 1                          | 0 to 590 Hz, 9999 | 9999             |
| 693       | Second free thermal reduction ratio 1                              | 1% to 100%        | 100%             |
| 694       | Second free thermal reduction frequency 2                          | 0 to 590 Hz, 9999 | 9999             |
| 695       | Second free thermal reduction ratio 2                              | 1% to 100%        | 100%             |
| 696       | Second free thermal reduction frequency 3                          | 0 to 590 Hz, 9999 | 9999             |
| 698       | Speed control D gain   | 0% to 100%        | 0%               |
| 699       | Input terminal filter  | 5 to 50 ms, 9999  | 9999             |

Parameter 700 to 799

| Parameter | Name  | Setting Range              | Initial Value *1 |
|-----------|---|----------------------------|------------------|
| 702       | Maximum motor frequency                               | 0 to 400 Hz, 9999          | 9999             |
| 706       | Induced voltage constant (phi f)                      | 0 to 5000 mV (rad/s), 9999 | 9999             |
| 707       | Motor inertia (integer)                               | 10 to 999, 9999            | 9999             |
| 711       | Motor Ld decay ratio                                  | 0% to 100%, 9999           | 9999             |
| 712       | Motor Lq decay ratio                                  | 0% to 100%, 9999           | 9999             |
| 717       | Starting resistance tuning compensation coefficient 1 | 0% to 200%, 9999           | 9999             |
| 720       | Starting resistance tuning compensation coefficient 2 | 0% to 200%, 9999           | 9999             |

| Parameter | Name   | Setting Range  | Initial Value *1 |
|-----------|--|--|------------------|
| 721       | Starting magnetic pole position detection pulse width              | 0 to 6000 $\mu$ s, 9999  | 9999             |
| 724       | Motor inertia (exponent)   | 0 to 7, 9999   | 9999             |
| 725       | Motor protection current level                                     | 100% to 500%, 9999   | 9999             |
| 728       | Device instance number (Upper 3 digits) [E800-(SC)EPA]             | 0 to 419   | 0                |
| 729       | Device instance number (Lower 4 digits) [E800-(SC)EPA]             | 0 to 9999  | 0                |
| 737       | Second motor starting resistance tuning compensation coefficient 2 | 0% to 200%, 9999   | 9999             |
| 738       | Second motor induced voltage constant ( $\phi$ f)                  | 0 to 5000 mV (rad/s), 9999   | 9999             |
| 739       | Second motor Ld decay ratio  | 0% to 100%, 9999   | 9999             |
| 740       | Second motor Lq decay ratio  | 0% to 100%, 9999   | 9999             |
| 741       | Second motor starting resistance tuning compensation coefficient 1 | 0% to 200%, 9999   | 9999             |
| 742       | Second motor magnetic pole detection pulse width                   | 0 to 6000 $\mu$ s, 9999  | 9999             |
| 743       | Second motor maximum frequency                                     | 0 to 400 Hz, 9999  | 9999             |
| 744       | Second motor inertia (integer)                                     | 10 to 999, 9999  | 9999             |
| 745       | Second motor inertia (exponent)                                    | 0 to 7, 9999   | 9999             |
| 746       | Second motor protection current level                              | 100% to 500%, 9999   | 9999             |
| 759       | PID unit selection   | 0 to 43, 9999  | 9999             |
| 774       | Operation panel monitor selection 1                                | [E800]<br>[E800-(SC)EPB]<br>1 to 3, 5 to 14, 17 to 20, 23 to 33, 35, 38, 40 to 42, 44, 45, 50 to 57, 61, 62, 64, 65, 67, 91, 97, 100, 9999 | 9999             |
| 775       | Operation panel monitor selection 2                                | [E800-(SC)EPA]<br>1 to 3, 5 to 14, 17 to 20, 23 to 33, 35, 38, 40 to 42, 44, 45, 50 to 57, 61, 62, 64, 65, 67, 83, 91, 97, 100, 9999       | 9999             |
| 776       | Operation panel monitor selection 3                                | [E800-(SC)EPA]<br>1 to 3, 5 to 14, 17 to 20, 23 to 33, 35, 38, 40 to 42, 44, 45, 50 to 57, 61, 62, 64, 65, 67, 83, 91, 97, 100, 9999       | 9999             |
| 779       | Operation frequency during communication error                     | 0 to 590 Hz, 9999  | 9999             |
| 791*3     | Acceleration time in low-speed range                               | 0 to 3600 s, 9999  | 9999             |
| 792*3     | Deceleration time in low-speed range                               | 0 to 3600 s, 9999  | 9999             |

## Parameter 800 to 999

| Parameter | Name  | Setting Range                   | Initial Value *1           |
|-----------|---|---------------------------------|----------------------------|
| 800       | Control method selection                                    | 0 to 5, 9, 10 to 12, 19, 20, 40 | 40                         |
| 801       | Output limit level  | 0% to 400%, 9999                | 9999                       |
| 802       | Pre-excitation selection                                    | 0, 1                            | 0                          |
| 803       | Constant output range torque characteristic selection       | 0 to 2, 10                      | 0                          |
| 804       | Torque command source selection                             | 0, 1, 3 to 6                    | 0                          |
| 805       | Torque command value (RAM)                                  | 600% to 1400%                   | 1000%                      |
| 806       | Torque command value (RAM, EEPROM)                          | 600% to 1400%                   | 1000%                      |
| 807       | Speed limit selection                                       | 0, 1                            | 0                          |
| 808       | Speed limit   | 0 to 400 Hz                     | Gr.1: 60 Hz<br>Gr.2: 50 Hz |
| 809       | Reverse-side speed limit                                    | 0 to 400 Hz, 9999               | 9999                       |
| 810       | Torque limit input method selection                         | 0 to 2                          | 0                          |
| 811       | Set resolution switchover                                   | 0, 10                           | 0                          |
| 812       | Torque limit level (regeneration)                           | 0% to 400%, 9999                | 9999                       |
| 813       | Torque limit level (3rd quadrant)                           | 0% to 400%, 9999                | 9999                       |
| 814       | Torque limit level (4th quadrant)                           | 0% to 400%, 9999                | 9999                       |
| 815       | Torque limit level 2  | 0% to 400%, 9999                | 9999                       |
| 816       | Torque limit level during acceleration                      | 0% to 400%, 9999                | 9999                       |
| 817       | Torque limit level during deceleration                      | 0% to 400%, 9999                | 9999                       |
| 820       | Speed control P gain 1                                      | 0% to 1000%                     | 60%                        |
| 821       | Speed control integral time 1                               | 0 to 20 s                       | 0.333 s                    |
| 822       | Speed setting filter 1                                      | 0 to 5 s, 9999                  | 9999                       |
| 823*4     | Speed detection filter 1                                    | 0 to 0.01 s                     | 0.001 s                    |
| 824       | Torque control P gain 1 (current loop proportional gain)    | 0% to 500%                      | 100%                       |
| 825       | Torque control integral time 1 (current loop integral time) | 0 to 500 ms                     | 5 ms                       |
| 826       | Torque setting filter 1                                     | 0 to 5 s, 9999                  | 9999                       |
| 828       | Model speed control gain                                    | 0 to 1000 rad/s                 | 100 rad/s                  |
| 830       | Speed control P gain 2                                      | 0% to 1000%, 9999               | 9999                       |
| 831       | Speed control integral time 2                               | 0 to 20 s, 9999                 | 9999                       |
| 832       | Speed setting filter 2                                      | 0 to 5 s, 9999                  | 9999                       |
| 833*4     | Speed detection filter 2                                    | 0 to 0.01 s, 9999               | 9999                       |



| Parameter | Name  | Setting Range       | Initial Value *1 |
|-----------|---|---------------------|------------------|
| 834       | Torque control P gain 2 (current loop proportional gain)          | 0% to 500%, 9999    | 9999             |
| 835       | Torque control integral time 2 (current loop integral time)       | 0 to 500 ms, 9999   | 9999             |
| 836       | Torque setting filter 2   | 0 to 5 s, 9999      | 9999             |
| 840       | Torque bias selection   | 0 to 3, 9999        | 9999             |
| 841       | Torque bias 1   | 600% to 1400%, 9999 | 9999             |
| 842       | Torque bias 2   | 600% to 1400%, 9999 | 9999             |
| 843       | Torque bias 3   | 600% to 1400%, 9999 | 9999             |
| 844       | Torque bias filter  | 0 to 5 s, 9999      | 9999             |
| 845       | Torque bias operation time  | 0 to 5 s, 9999      | 9999             |
| 846       | Torque bias balance compensation                                  | 0% to 100%, 9999    | 9999             |
| 847       | Fall-time torque bias terminal 4 bias                             | 0% to 400%, 9999    | 9999             |
| 848       | Fall-time torque bias terminal 4 gain                             | 0% to 400%, 9999    | 9999             |
| 849       | Analog input offset adjustment                                    | 0% to 200%          | 100%             |
| 850       | Brake operation selection   | 0 to 2              | 0                |
| 853       | Speed deviation time  | 0 to 100 s          | 1 s              |
| 854       | Excitation ratio  | 0% to 100%          | 100%             |
| 858       | Terminal 4 function assignment                                    | 0, 4, 6, 9999       | 0                |
| 859       | Torque current/Rated PM motor current                             | 0 to 500 A, 9999    | 9999             |
| 860       | Second motor torque current/Rated PM motor current                | 0 to 500 A, 9999    | 9999             |
| 864       | Torque detection  | 0% to 400%          | 150%             |
| 865       | Low speed detection   | 0 to 590 Hz         | 1.5 Hz           |
| 866       | Torque monitoring reference                                       | 0% to 400%          | 150%             |
| 867       | AM output filter [E800-4][E800-5]                                 | 0 to 5 s            | 0.01 s           |
| 870       | Speed detection hysteresis  | 0 to 15 Hz          | 0 Hz             |
| 872       | Input phase loss protection selection [3-phase]                   | 0, 1                | 1                |
| 873*4     | Speed limit   | 0 to 400 Hz         | 20 Hz            |
| 874       | OLT level setting   | 0% to 400%          | 150%             |
| 877       | Speed feed forward control/model adaptive speed control selection | 0 to 2              | 0                |
| 878       | Speed feed forward filter   | 0.01 to 1 s         | 0.01 s           |
| 879       | Speed feed forward torque limit                                   | 0% to 400%          | 150%             |
| 880       | Load inertia ratio  | 0 to 200 times      | 7 times          |
| 881       | Speed feed forward gain   | 0% to 1000%         | 0%               |

| Parameter | Name   | Setting Range  | Initial Value *1   |
|-----------|--|--|--|
| 882       | Regeneration avoidance operation selection                 | 0 to 2   | 0  |
| 883       | Regeneration avoidance operation level                     | 300 to 1200 V  | [200 V class]<br>400 V<br>[400 V class]<br>780 V<br>[575 V class]<br>944 V |
| 885       | Regeneration avoidance compensation frequency limit value  | 0 to 45 Hz, 9999   | 6 Hz   |
| 886       | Regeneration avoidance voltage gain                        | 0% to 200%   | 100%   |
| 888       | Free parameter 1   | 0 to 9999  | 9999   |
| 889       | Free parameter 2   | 0 to 9999  | 9999   |
| 891       | Cumulative power monitor digit shifted times               | 0 to 4, 9999   | 9999   |
| 892       | Load factor  | 30% to 150%  | 100%   |
| 893       | Energy saving monitor reference (motor capacity)           | 0.1 to 30 kW   | Inverter rated capacity  |
| 894       | Control selection during commercial power-supply operation | 0 to 3   | 0  |
| 895       | Power saving rate reference value                          | 0, 1, 9999   | 9999   |
| 896       | Power unit cost  | 0 to 500, 9999   | 9999   |
| 897       | Power saving monitor average time                          | 0 to 1000 h, 9999  | 9999   |
| 898       | Power saving cumulative monitor clear                      | 0, 1, 10, 9999   | 9999   |
| 899       | Operation time rate (estimated value)                      | 0% to 100%, 9999   | 9999   |
| 986       | Display safety fault code [E800-SCE]                       | 0 to 127   | 0  |
| 990       | PU buzzer control  | 0, 1   | 1  |
| 991       | PU contrast adjustment                                     | 0 to 63  | 58   |
| 992       | Operation panel setting dial push monitor selection [E800] | 0 to 3, 5 to 14, 17 to 20, 23 to 33, 35, 38, 40 to 42, 44, 45, 50 to 57, 61, 62, 64, 65, 67, 91, 97, 100 | 0  |
| 997       | Fault initiation   | 0 to 255, 9999   | 9999   |
| 998       | PM parameter initialization <i>Simple</i>                  | 0, 8009, 8109, 9009, 9109,   | 0  |
| 999       | Automatic parameter setting <i>Simple</i>                  | 10, 12, 20, 21, 9999   | 9999   |

Parameter 1000 to 1099

| Parameter | Name  | Setting Range     | Initial Value *1 |
|-----------|---|-------------------|------------------|
| 1002      | Lq tuning target current adjustment coefficient | 50% to 150%, 9999 | 9999             |
| 1006      | Clock (year)                                    | 2000 to 2099      | 2000             |

| Parameter | Name   | Setting Range   | Initial Value *1 |   |
|-----------|--|---|------------------|---|
| 1007      | Clock (month, day)                           | Jan. 1 to Dec. 31   | 101              |   |
| 1008      | Clock (hour, minute)                         | 0:00 to 23:59   | 0                |   |
| 1015      | Integral stop selection at limited frequency | 0 to 2  | 0                |   |
| 1016      | PTC thermistor protection detection time     | 0 to 60 s   | 0 s              |   |
| 1020      | Trace operation selection                    | 0 to 3  | 0                |   |
| 1022      | Sampling cycle                               | 1, 2, 5, 10, 50, 100, 500, 1000   | 1                |   |
| 1023      | Number of analog channels                    | 1 to 8  | 4                |   |
| 1024      | Sampling auto start                          | 0, 1  | 0                |   |
| 1025      | Trigger mode selection                       | 0 to 4  | 0                |   |
| 1026      | Number of sampling before trigger            | 0% to 100%  | 90%              |   |
| 1027      | Analog source selection (1ch)                | 1 to 3, 5 to 14, 17 to 20, 23, 24, 32, 33, 35, 40 to 42, 52 to 54, 61, 62, 64, 65, 67, 83<br>[E800-(SC)EPA], 91, 97, 201 to 210, 212, 213, 222 to 227, 229 to 232, 235 to 238 | 201              |   |
| 1028      | Analog source selection (2ch)                |   | 202              |   |
| 1029      | Analog source selection (3ch)                |   | 203              |   |
| 1030      | Analog source selection (4ch)                |   | 204              |   |
| 1031      | Analog source selection (5ch)                |   | 205              |   |
| 1032      | Analog source selection (6ch)                |   | 206              |   |
| 1033      | Analog source selection (7ch)                |   | 207              |   |
| 1034      | Analog source selection (8ch)                |   | 208              |   |
| 1035      | Analog trigger channel                       |   | 1 to 8           | 1 |
| 1036      | Analog trigger operation selection           |   | 0, 1             | 0 |
| 1037      | Analog trigger level                         | 600 to 1400   | 1000             |   |
| 1038      | Digital source selection (1ch)               | 0 to 255  | 0                |   |
| 1039      | Digital source selection (2ch)               |   | 0                |   |
| 1040      | Digital source selection (3ch)               |   | 0                |   |
| 1041      | Digital source selection (4ch)               |   | 0                |   |
| 1042      | Digital source selection (5ch)               |   | 0                |   |
| 1043      | Digital source selection (6ch)               |   | 0                |   |
| 1044      | Digital source selection (7ch)               |   | 0                |   |
| 1045      | Digital source selection (8ch)               |   | 0                |   |
| 1046      | Digital trigger channel                      |   | 1 to 8           | 1 |
| 1047      | Digital trigger operation selection          | 0, 1  | 0                |   |

Parameter 1100 to 1399

| Parameter    | Name   | Setting Range                    | Initial Value *1 |
|--------------|--|----------------------------------|------------------|
| 1103*3       | Deceleration time at emergency stop                                  | 0 to 3600 s                      | 5 s              |
| 1106         | Torque monitor filter  | 0 to 5 s, 9999                   | 9999             |
| 1107         | Running speed monitor filter   | 0 to 5 s, 9999                   | 9999             |
| 1108         | Excitation current monitor filter                                    | 0 to 5 s, 9999                   | 9999             |
| 1124         | Station number in inverter-to-inverter link [E800-(SC)E]             | 0 to 5, 9999                     | 9999             |
| 1125         | Number of inverters in inverter-to-inverter link system [E800-(SC)E] | 2 to 6                           | 2                |
| 1150 to 1199 | PLC function user parameters 1 to 50                                 | 0 to 65535                       | 0                |
| 1200         | AM output offset calibration [E800-4][E800-5]                        | 2700 to 3300                     | 3000             |
| 1222         | First positioning acceleration time                                  | 0.01 to 360 s                    | 5 s              |
| 1223         | First positioning deceleration time                                  | 0.01 to 360 s                    | 5 s              |
| 1225         | First positioning subfunction  | 0, 1, 10, 11, 100, 101, 110, 111 | 10               |
| 1226         | Second positioning acceleration time                                 | 0.01 to 360 s                    | 5 s              |
| 1227         | Second positioning deceleration time                                 | 0.01 to 360 s                    | 5 s              |
| 1229         | Second positioning subfunction                                       | 0, 1, 10, 11, 100, 101, 110, 111 | 10               |
| 1230         | Third positioning acceleration time                                  | 0.01 to 360 s                    | 5 s              |
| 1231         | Third positioning deceleration time                                  | 0.01 to 360 s                    | 5 s              |
| 1233         | Third positioning subfunction  | 0, 1, 10, 11, 100, 101, 110, 111 | 10               |
| 1234         | Fourth positioning acceleration time                                 | 0.01 to 360 s                    | 5 s              |
| 1235         | Fourth positioning deceleration time                                 | 0.01 to 360 s                    | 5 s              |
| 1237         | Fourth positioning subfunction                                       | 0, 1, 10, 11, 100, 101, 110, 111 | 10               |
| 1238         | Fifth positioning acceleration time                                  | 0.01 to 360 s                    | 5 s              |
| 1239         | Fifth positioning deceleration time                                  | 0.01 to 360 s                    | 5 s              |
| 1241         | Fifth positioning subfunction  | 0, 1, 10, 11, 100, 101, 110, 111 | 10               |
| 1242         | Sixth positioning acceleration time                                  | 0.01 to 360 s                    | 5 s              |
| 1243         | Sixth positioning deceleration time                                  | 0.01 to 360 s                    | 5 s              |
| 1245         | Sixth positioning subfunction  | 0, 1, 10, 11, 100, 101, 110, 111 | 10               |
| 1246         | Seventh positioning acceleration time                                | 0.01 to 360 s                    | 5 s              |
| 1247         | Seventh positioning deceleration time                                | 0.01 to 360 s                    | 5 s              |



| Parameter    | Name  | Setting Range  | Initial Value *1 |
|--------------|---|--|------------------|
| 1249         | Seventh positioning subfunction   | 0, 10, 100, 110  | 10               |
| 1282         | Home position return method selection   | 2, 3, 4, 6, 103, 106, 203, 206   | 4                |
| 1283         | Home position return speed  | 0 to 400 Hz  | 2 Hz             |
| 1285         | Home position shift amount lower 4 digits                                       | 0 to 9999  | 0                |
| 1286         | Home position shift amount upper 4 digits                                       | 0 to 9999  | 0                |
| 1289         | Home position return stopper torque   | 0% to 200%   | 40%              |
| 1290         | Home position return stopper waiting time                                       | 0 to 10 s  | 0.5 s            |
| 1292         | Position control terminal input selection                                       | 0, 1, 10, 11, 100, 101, 110, 111   | 0                |
| 1293         | Roll feeding mode selection   | 0 to 2   | 0                |
| 1294         | Position detection lower 4 digits   | 0 to 9999  | 0                |
| 1295         | Position detection upper 4 digits   | 0 to 9999  | 0                |
| 1296         | Position detection selection  | 0 to 2   | 0                |
| 1297         | Position detection hysteresis width   | 0 to 32767   | 0                |
| 1318         | User Defined Cyclic Communication Input fixing format selection [E800-(SC)EPA]  | 20 to 23, 9999   | 9999             |
| 1319         | User Defined Cyclic Communication Output fixing format selection [E800-(SC)EPA] | 70 to 73, 9999   | 9999             |
| 1220 to 1329 | User Defined Cyclic Communication Input 1 to 10 Mapping [E800-(SC)E]            | [E800-(SC)EPA] 12288 to 13787, 20488, 20489, 9999<br>[E800-(SC)EPB] 5, 100, 12288 to 13787, 20488, 20489, 9999   | 9999             |
| 1330 to 1343 | User Defined Cyclic Communication Output 1 to 14 Mapping [E800-(SC)E]           | [E800-(SC)EPA] 12288 to 13787, 16384 to 16483, 20488, 20489, 20981 to 20990, 9999<br>[E800-(SC)EPB] 6, 101, 12288 to 13787, 16384 to 16483, 20488, 20489, 20981 to 20990, 9999 | 9999             |
| 1399         | Inverter identification enable/disable selection [E800-(SC)E]                   | 0, 1   | 1                |

Parameter 1400 to 1499

| Parameter | Name   | Setting Range   | Initial Value *1 |
|-----------|--|---|------------------|
| 1412      | Motor induced voltage constant (phi f) exponent                | 0 to 2, 9999  | 9999             |
| 1413      | Second motor induced voltage constant (phi f) exponent         | 0 to 2, 9999  | 9999             |
| 1424      | Ethernet communication network number [E800-(SC)E]             | 1 to 239  | 1                |
| 1425      | Ethernet communication station number [E800-(SC)E]             | 1 to 120  | 1                |
| 1426      | Link speed and duplex mode selection [E800-(SC)E]              | 0 to 4  | 0                |
| 1427      | Ethernet function selection 1 [E800-(SC)E]                     | [E800-(SC)EPA] 502, 5000 to 5002, 5006 to 5008, 5010 to 5013, 44818, 45237, 45238, 47808, 61450, 9999 | 5001             |
| 1428      | Ethernet function selection 2 [E800-(SC)E]                     | [E800-(SC)EPA] 502, 5000 to 5002, 5006 to 5008, 5010 to 5013, 34962, 45237, 45238, 61450, 9999        | 45237            |
| 1429      | Ethernet function selection 3 [E800-(SC)E]                     | [E800-(SC)EPB] 502, 5000 to 5002, 5006 to 5008, 5010 to 5013, 34962, 45237, 45238, 61450, 9999        | 45238            |
| 1430      | Ethernet function selection 4 [E800-(SC)E]                     |   | 9999             |
| 1431      | Ethernet signal loss detection function selection [E800-(SC)E] | 0 to 3  | 3                |
| 1432      | Ethernet communication check time interval [E800-(SC)E]        | 0 to 999.8 s, 9999  | 1.5              |
| 1434      | Ethernet IP address 1 [E800-(SC)E]                             | 0 to 255  | 192              |
| 1435      | Ethernet IP address 2 [E800-(SC)E]                             | 0 to 255  | 168              |
| 1436      | Ethernet IP address 3 [E800-(SC)E]                             | 0 to 255  | 50               |
| 1437      | Ethernet IP address 4 [E800-(SC)E]                             | 0 to 255  | 1                |
| 1438      | Subnet mask 1 [E800-(SC)E]                                     | 0 to 255  | 255              |
| 1439      | Subnet mask 2 [E800-(SC)E]                                     | 0 to 255  | 255              |
| 1440      | Subnet mask 3 [E800-(SC)E]                                     | 0 to 255  | 255              |
| 1441      | Subnet mask 4 [E800-(SC)E]                                     | 0 to 255  | 0                |
| 1442      | IP filter address 1 (Ethernet) [E800-(SC)E]                    | 0 to 255  | 0                |
| 1443      | IP filter address 2 (Ethernet) [E800-(SC)E]                    | 0 to 255  | 0                |
| 1444      | IP filter address 3 (Ethernet) [E800-(SC)E]                    | 0 to 255  | 0                |

| Parameter | Name  | Setting Range           | Initial Value *1           |
|-----------|---|-------------------------|----------------------------|
| 1445      | IP filter address 4 (Ethernet) [E800-(SC)E]   | 0 to 255                | 0                          |
| 1446      | IP filter address 2 range specification (Ethernet) [E800-(SC)E]                     | 0 to 255, 9999          | 9999                       |
| 1447      | IP filter address 3 range specification (Ethernet) [E800-(SC)E]                     | 0 to 255, 9999          | 9999                       |
| 1448      | IP filter address 4 range specification (Ethernet) [E800-(SC)E]                     | 0 to 255, 9999          | 9999                       |
| 1449      | Ethernet command source selection IP address 1 [E800-(SC)E]                         | 0 to 255                | 0                          |
| 1450      | Ethernet command source selection IP address 2 [E800-(SC)E]                         | 0 to 255                | 0                          |
| 1451      | Ethernet command source selection IP address 3 [E800-(SC)E]                         | 0 to 255                | 0                          |
| 1452      | Ethernet command source selection IP address 4 [E800-(SC)E]                         | 0 to 255                | 0                          |
| 1453      | Ethernet command source selection IP address 3 range specification [E800-(SC)E]     | 0 to 255, 9999          | 9999                       |
| 1454      | Ethernet command source selection IP address 4 range specification [E800-(SC)E]     | 0 to 255, 9999          | 9999                       |
| 1455      | Kealive time [E800-(SC)E]   | 1 to 7200 s             | 60 s                       |
| 1456      | Network diagnosis selection [E800-(SC)E]  | 0 to 2, 9999            | 9999                       |
| 1457      | Extended setting for Ethernet signal loss detection function selection [E800-(SC)E] | 0 to 3, 8888, 9999      | 9999                       |
| 1480      | Load characteristics measurement mode   | 0, 1 (2 to 5, 81 to 85) | 0                          |
| 1481      | Load characteristics load reference 1   | 0% to 400%, 8888, 9999  | 9999                       |
| 1482      | Load characteristics load reference 2   | 0% to 400%, 8888, 9999  | 9999                       |
| 1483      | Load characteristics load reference 3   | 0% to 400%, 8888, 9999  | 9999                       |
| 1484      | Load characteristics load reference 4   | 0% to 400%, 8888, 9999  | 9999                       |
| 1485      | Load characteristics load reference 5   | 0% to 400%, 8888, 9999  | 9999                       |
| 1486      | Load characteristics maximum frequency  | 0 to 590 Hz             | Gr.1: 60 Hz<br>Gr.2: 50 Hz |
| 1487      | Load characteristics minimum frequency  | 0 to 590 Hz             | 6 Hz                       |

| Parameter | Name  | Setting Range    | Initial Value *1 |
|-----------|---|------------------|------------------|
| 1488      | Upper limit warning detection width   | 0% to 400%, 9999 | 20%              |
| 1489      | Lower limit warning detection width   | 0% to 400%, 9999 | 20%              |
| 1490      | Upper limit fault detection width   | 0% to 400%, 9999 | 9999             |
| 1491      | Lower limit fault detection width   | 0% to 400%, 9999 | 9999             |
| 1492      | Load status detection signal delay time / load reference measurement waiting time | 0 to 60 s        | 1 s              |
| 1499      | Parameter for manufacturer setting. Do not set.                                   |                  |                  |

## Alphabet (calibration parameters, etc.)

| Parameter               | Name   | Setting Range  | Initial Value *1           |
|-------------------------|--|----------------|----------------------------|
| C0 (900) <sup>*5</sup>  | FM terminal calibration [E800-1]               | —              | —                          |
| C1 (901) <sup>*5</sup>  | AM terminal calibration [E800-4][E800-5]       | —              | —                          |
| C2 (902) <sup>*5</sup>  | Terminal 2 frequency setting bias frequency    | 0 to 590 Hz    | 0 Hz                       |
| C3 (902) <sup>*5</sup>  | Terminal 2 frequency setting bias              | 0% to 300%     | 0%                         |
| 125 (903) <sup>*5</sup> | Terminal 2 frequency setting gain frequency    | 0 to 590 Hz    | Gr.1: 60 Hz<br>Gr.2: 50 Hz |
| C4 (903) <sup>*5</sup>  | Terminal 2 frequency setting gain              | 0% to 300%     | 100%                       |
| C5 (904) <sup>*5</sup>  | Terminal 4 frequency setting bias frequency    | 0 to 590 Hz    | 0 Hz                       |
| C6 (904) <sup>*5</sup>  | Terminal 4 frequency setting bias              | 0% to 300%     | 20%                        |
| 126 (905) <sup>*5</sup> | Terminal 4 frequency setting gain frequency    | 0 to 590 Hz    | Gr.1: 60 Hz<br>Gr.2: 50 Hz |
| C7 (905) <sup>*5</sup>  | Terminal 4 frequency setting gain              | 0% to 300%     | 100%                       |
| C38 (932) <sup>*5</sup> | Terminal 4 bias command (torque/magnetic flux) | 0% to 400%     | 0%                         |
| C39 (932) <sup>*5</sup> | Terminal 4 bias (torque/magnetic flux)         | 0% to 300%     | 0%                         |
| C40 (933) <sup>*5</sup> | Terminal 4 gain command (torque/magnetic flux) | 0% to 400%     | 150%                       |
| C41 (933) <sup>*5</sup> | Terminal 4 gain (torque/magnetic flux)         | 0% to 300%     | 100%                       |
| C42 (934) <sup>*5</sup> | PID display bias coefficient                   | 0 to 500, 9999 | 9999                       |
| C43 (934) <sup>*5</sup> | PID display bias analog value                  | 0% to 300%     | 20%                        |



| Parameter                                | Name                                 | Setting Range  | Initial Value <sup>*1</sup> |
|--|--------------------------------------|----------------|-----------------------------|
| <b>C44</b><br><b>(935)</b> <sup>*5</sup> | <b>PID display gain coefficient</b>  | 0 to 500, 9999 | 9999                        |
| <b>C45</b><br><b>(935)</b> <sup>*5</sup> | <b>PID display gain analog value</b> | 0% to 300%     | 100%                        |
| <b>PR.CL</b>                             | <b>Parameter clear</b>               | (0), 1         | 0                           |
| <b>ALLC</b>                              | <b>All parameter clear</b>           | (0), 1         | 0                           |
| <b>ER.CL</b>                             | <b>Fault history clear</b>           | (0), 1         | 0                           |
| <b>PR.CH</b>                             | <b>Initial value change list</b>     | —              | 0                           |
| <b>PM</b>                                | <b>PM parameter initialization</b>   | 0              | 0                           |
| <b>AUTO</b>                              | <b>Automatic parameter setting</b>   | —              | —                           |
| <b>PR.MD</b>                             | <b>Group parameter setting</b>       | (0), 1, 2      | 0                           |

<sup>\*1</sup> Gr.1 and Gr.2 are the parameter initial value groups.

<sup>\*2</sup> Differs depending on the capacity. (see Instruction Manual (Function) for more details).

<sup>\*3</sup> The set value is read/written in 2-word (32-bit) units when the PLC function is used for parameter reading/writing.

<sup>\*4</sup> The setting is available only when a Vector control compatible option is installed.

<sup>\*5</sup> On the LCD operation panel used as the command source, the parameter number in parentheses appears instead of that starting with the letter C.

<sup>\*6</sup> For the Ethernet model and the safety communication model, the setting is available only when the FR-A8AY is installed.

<sup>\*7</sup> Available when the PLC function is enabled. (Pr.313 to Pr.315 are always available for settings in the Ethernet model and the safety communication model.)

<sup>\*8</sup> For the standard model, the setting is available only when a communication option is installed.

---

---

## 7 INVERTER FAULT AND ALARM INDICATIONS

---

---

When the inverter detects a fault, depending on the nature of the fault, the operation panel displays an error message or warning, or a protective function is activated to shut off the inverter output.

When any fault occurs, take an appropriate corrective action, then reset the inverter, and resume the operation. Restarting the operation without a reset may break or damage the inverter.

When a protective function is activated, note the following points.

- Fault output signal .....Opening the magnetic contactor (MC) provided on the input side of the inverter at a fault occurrence shuts off the control power to the inverter, therefore, the fault output will not be retained.
- Fault or alarm indication .....When a protective function is activated, the operation panel displays a fault indication.
- Operation restart method .....While a protective function is activated, the inverter output is kept shutoff. Reset the inverter to restart the operation.

Inverter fault or alarm indications are categorized as follows.

- Error Message  
A message regarding operational fault or setting fault on the operation panel is displayed. The inverter output is not shut off.
- Warning  
The inverter output is not shut off even when a warning is displayed. However, failure to take appropriate measures will lead to a fault.
- Alarm  
The inverter output is not shut off. An Alarm (LF) signal can also be output with a parameter setting.
- Fault  
When a protective function is activated, the inverter output is shut off and a Fault (ALM) signal is output.

### NOTES

- The last 10 faults can be displayed on the operation panel. (Fault history) (For operation, refer to *page 38*.)



## 7.1 Reset method of protective function

The inverter can be reset by performing any of the following operations. Note that the internal thermal integrated value of the electronic thermal relay function and the number of retries are cleared (erased) by resetting the inverter. Inverter recovers about 1s after reset is cancelled.

Three different methods can be used to reset an inverter.

- Using the operation panel, press the STOP/RESET key to reset the inverter. (This may only be performed when a fault occurs.)

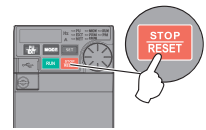

- Switch OFF the power once, then switch it ON again after the indicator of the operation panel turns OFF.

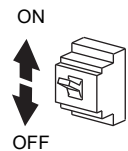

- Turn ON the reset signal (RES) for more than 0.1s. (If the RES signal is kept ON, "Err." appears (flickers) to indicate that the inverter is in a reset status.)

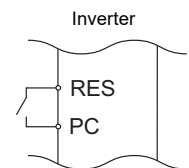

### CAUTION

OFF status of the start signal must be confirmed before resetting the inverter fault. Resetting inverter fault with the start signal ON restarts the motor suddenly. This may cause injury.

## 7.2 List of alarm display

| Operation panel indication |              | Name       | Data code                                   |         |
|----------------------------|--------------|------------|---|---------|
| Error message              | Hold         | HOLD       | Operation panel lock                        | —       |
|                            | LoLd         | LOCD       | Password locked                             | —       |
|                            | Er 1 to Er 4 | Er1 to Er4 | Parameter write error                       | —       |
|                            | Err.         | Err.       | Error                                       | —       |
| Warning                    | oLl          | OLC        | Stall prevention (overcurrent)              | 1 (H01) |
|                            | oLv          | OLV        | Stall prevention (overvoltage)              | 2 (H02) |
|                            | rb           | RB         | Regenerative brake pre-alarm                | 3 (H03) |
|                            | TH           | TH         | Electronic thermal relay function pre-alarm | 4 (H04) |
|                            | PS           | PS         | PU stop                                     | 6 (H06) |

| Operation panel indication |     | Name | Data code                                 |          |
|----------------------------|-----|------|---|----------|
| Warning                    | MT  | MT   | Maintenance timer                         | 8 (H08)  |
|                            | SL  | SL   | Speed limit indication                    | 9 (H09)  |
|                            | CF  | CF   | Continuous operation during communication | 10 (H0A) |
|                            | SA  | SA   | Safety stop                               | 12 (H0C) |
|                            | LDF | LDF  | Load fault warning                        | 26 (H1A) |
|                            | EHR | EHR  | Ethernet communication fault              | 28 (H1C) |
|                            | dIP | DIP  | Duplicate IP address                      | 32 (H20) |
|                            | IP  | IP   | IP address fault                          | 38 (H26) |
|                            | SE  | SE   | Incorrect parameter setting               | 48 (H30) |
|                            | UV  | UV   | Undervoltage                              | —        |
|                            | LP  | LP   | Stroke limit warning                      | 20 (H14) |
|                            | HP1 | HP1  | Home position return setting error        | 21 (H15) |
|                            | HP2 | HP2  | Home position return uncompleted          | 22 (H16) |

| Operation panel indication |                        | Name  | Data code  |  |
|----------------------------|------------------------|-------|--|--|
| Alarm                      | <i>F<sub>n</sub></i>   | FN    | Fan alarm  |  |
|                            | <i>E<sub>oC1</sub></i> | E.OC1 | Overcurrent trip during acceleration                       |  |
| Fault                      | <i>E<sub>oC2</sub></i> | E.OC2 | Overcurrent trip during constant speed                     |  |
|                            | <i>E<sub>oC3</sub></i> | E.OC3 | Overcurrent trip during deceleration or stop               |  |
|                            | <i>E<sub>ov1</sub></i> | E.OV1 | Regenerative overvoltage trip during acceleration          |  |
|                            | <i>E<sub>ov2</sub></i> | E.OV2 | Regenerative overvoltage trip during constant speed        |  |
|                            | <i>E<sub>ov3</sub></i> | E.OV3 | Regenerative overvoltage trip during deceleration or stop  |  |
|                            | <i>E<sub>THT</sub></i> | E.THT | Inverter overload trip (electronic thermal relay function) |  |
| Fault                      | <i>E<sub>THT</sub></i> | E.THT | Inverter overload trip (electronic thermal relay function) |  |
|                            | <i>E<sub>THT</sub></i> | E.THT | Inverter overload trip (electronic thermal relay function) |  |
|                            | <i>E<sub>THT</sub></i> | E.THT | Inverter overload trip (electronic thermal relay function) |  |
|                            | <i>E<sub>THM</sub></i> | E.THM | Motor overload trip (electronic thermal relay function)    |  |
|                            | <i>E<sub>FIN</sub></i> | E.FIN | Heat sink overheat   |  |
|                            | <i>E<sub>UVF</sub></i> | E.UVT | Undervoltage   |  |
|                            | <i>E<sub>ILF</sub></i> | E.ILF | Input phase loss   |  |
|                            | <i>E<sub>OLT</sub></i> | E.OLT | Stall prevention stop                                      |  |
|                            | <i>E<sub>SOT</sub></i> | E.SOT | Loss of synchronism detection                              |  |
|                            | <i>E<sub>LUP</sub></i> | E.LUP | Upper limit fault detection                                |  |
|                            | <i>E<sub>LDN</sub></i> | E.LDN | Lower limit fault detection                                |  |
|                            | <i>E<sub>BE</sub></i>  | E.BE  | Brake transistor alarm detection                           |  |
|                            | <i>E<sub>GF</sub></i>  | E.GF  | Output side earth (ground) fault overcurrent               |  |
|                            | <i>E<sub>LF</sub></i>  | E.LF  | Output phase loss  |  |
|                            | <i>E<sub>OHT</sub></i> | E.OHT | External thermal relay operation                           |  |
|                            | <i>E<sub>PTC</sub></i> | E.PTC | PTC thermistor operation                                   |  |
|                            | <i>E<sub>OPT</sub></i> | E.OPT | Option fault   |  |
|                            | <i>E<sub>OP1</sub></i> | E.OP1 | Communication option fault                                 |  |
|                            | <i>E.16</i>            | E.16  | User definition error by the PLC function                  |  |
|                            | <i>E.17</i>            | E.17  |  |  |
|                            | <i>E.18</i>            | E.18  |  |  |
|                            | <i>E.19</i>            | E.19  |  |  |
|                            | <i>E.20</i>            | E.20  |  |  |
|                            | <i>E<sub>PE</sub></i>  | E.PE  |  | Parameter storage device fault (control circuit board) |
|                            | <i>E<sub>PUE</sub></i> | E.PUE |  | PU disconnection                                       |
|                            | <i>E<sub>RET</sub></i> | E.RET |  | Retry count excess                                     |

| Operation panel indication |                        | Name         | Data code   |
|----------------------------|------------------------|--------------|---|
| Fault                      | <i>E<sub>PE2</sub></i> | E.PE2        | Parameter storage device fault (main circuit board) |
|                            | <i>E<sub>CPU</sub></i> | E.CPU        | CPU fault   |
|                            | <i>E<sub>CDO</sub></i> | E.CDO        | Abnormal output current detection                   |
|                            | <i>E<sub>IOH</sub></i> | E.IOH        | Inrush current limit circuit fault                  |
|                            | <i>E<sub>AIE</sub></i> | E.AIE        | Analog input fault                                  |
|                            | <i>E<sub>USB</sub></i> | E.USB        | USB communication fault                             |
|                            | <i>E<sub>SAF</sub></i> | E.SAF        | Safety circuit fault                                |
|                            | <i>E<sub>OS</sub></i>  | E.OS         | Overspeed occurrence                                |
|                            | <i>E<sub>OSD</sub></i> | E.OSD        | Speed deviation excess detection                    |
|                            | <i>E<sub>MB1</sub></i> | E.MB1        | Brake sequence fault                                |
|                            | <i>E<sub>MB2</sub></i> | E.MB2        |   |
|                            | <i>E<sub>MB3</sub></i> | E.MB3        |   |
|                            | <i>E<sub>MB4</sub></i> | E.MB4        |   |
|                            | <i>E<sub>MB5</sub></i> | E.MB5        |   |
|                            | <i>E<sub>MB6</sub></i> | E.MB6        |   |
|                            | <i>E<sub>MB7</sub></i> | E.MB7        |   |
|                            | <i>E<sub>PID</sub></i> | E.PID        |   |
|                            | <i>E<sub>EHR</sub></i> | E.EHR        | Ethernet communication fault                        |
|                            | <i>E<sub>CMB</sub></i> | E.CMB        | Board combination fault                             |
|                            | <i>E.1</i>             | E.1          | Option fault  |
|                            | <i>E.5</i>             | E.5          | CPU fault   |
|                            | <i>E.6</i>             | E.6          |   |
|                            | <i>E.7</i>             | E.7          |   |
|                            | <i>E.10</i>            | E.10         | Inverter output fault                               |
|                            | <i>E.11</i>            | E.11         | Opposite rotation deceleration fault                |
|                            | <i>E.13</i>            | E.13         | Internal circuit fault                              |
|                            | Others                 | <i>E----</i> | E----   |
| <i>E0</i>                  |                        | —            | No fault history                                    |
| <i>rd</i>                  |                        | rd           | Backup in progress                                  |
|                            | <i>WR</i>              | WR           | Restoration in progress                             |



# 8 SPECIFICATIONS

## 8.1 Rating

### 8.1.1 Three-phase 200 V power supply

| Model FR-E820-□                         |  | 0008  | 0015               | 0030      | 0050               | 0080      | 0110        | 0175        | 0240        | 0330        | 0470        | 0600        | 0760        | 0900         |       |       |
|---|--|---|--------------------|-----------|--------------------|-----------|-------------|-------------|-------------|-------------|-------------|-------------|-------------|--------------|-------|-------|
|   |  | 0.1K  | 0.2K               | 0.4K      | 0.75K              | 1.5K      | 2.2K        | 3.7K        | 5.5K        | 7.5K        | 11K         | 15K         | 18.5K       | 22K          |       |       |
| Applicable motor capacity [kW] *1       | LD                                     | 0.2   | 0.4                | 0.75      | 1.1                | 2.2       | 3.0         | 5.5         | 7.5         | 11          | 15.0        | 18.5        | 22.0        | 30.0         |       |       |
|   | ND                                     | 0.1   | 0.2                | 0.4       | 0.75               | 1.5       | 2.2         | 3.7         | 5.5         | 7.5         | 11.0        | 15.0        | 18.5        | 22.0         |       |       |
| Rated capacity [kVA] *2                 | LD                                     | 0.5   | 0.8                | 1.4       | 2.4                | 3.8       | 4.8         | 7.8         | 12.0        | 15.9        | 22.3        | 27.5        | 35.1        | 45.8         |       |       |
|   | ND                                     | 0.3   | 0.6                | 1.2       | 2.0                | 3.2       | 4.4         | 7.0         | 9.6         | 13.1        | 18.7        | 23.9        | 30.3        | 35.9         |       |       |
| Rated current [A] *7                    | LD                                     | 1.3 (1.1)   | 2.0 (1.7)          | 3.5 (3.0) | 6.0 (5.1)          | 9.6 (8.2) | 12.0 (10.2) | 19.6 (16.7) | 30.0 (25.5) | 40.0 (34.0) | 56.0 (47.6) | 69.0 (58.7) | 88.0 (74.8) | 115.0 (97.8) |       |       |
|   | ND                                     | 0.8 (0.8)   | 1.5 (1.4)          | 3.0 (2.5) | 5.0 (4.1)          | 8.0 (7.0) | 11.0 (10.0) | 17.5 (16.5) | 24.0 (23.0) | 33.0 (31.0) | 47.0 (44.0) | 60.0 (57.0) | 76.0 (72.0) | 90.0 (86.0)  |       |       |
| Overload current rating *3              | LD                                     | 120% 60 s, 150% 3 s (inverse-time characteristics) at surrounding air temperature of 50°C |                    |           |                    |           |             |             |             |             |             |             |             |              |       |       |
|   | ND                                     | 150% 60 s, 200% 3 s (inverse-time characteristics) at surrounding air temperature of 50°C |                    |           |                    |           |             |             |             |             |             |             |             |              |       |       |
| Rated voltage *4                        |  | Three-phase 200 to 240 V  |                    |           |                    |           |             |             |             |             |             |             |             |              |       |       |
| Regenerative braking                    | Brake transistor                       | Not used  |                    |           | Built-in           |           |             |             |             |             |             |             |             |              |       |       |
|   | Maximum brake torque (ND reference) *5 | 150%  |                    |           | 100%               |           | 50%         |             | 20%         |             |             |             |             |              |       |       |
| Rated input AC (DC) voltage/frequency   |  | Three-phase 200 to 240 V, 50/60 Hz (283 to 339 VDC*9)                                     |                    |           |                    |           |             |             |             |             |             |             |             |              |       |       |
| Permissible AC (DC) voltage fluctuation |  | 170 to 264 V, 50/60 Hz (240 to 373 V DC*9)  |                    |           |                    |           |             |             |             |             |             |             |             |              |       |       |
| Permissible frequency fluctuation       |  | ±5%   |                    |           |                    |           |             |             |             |             |             |             |             |              |       |       |
| Power supply                            | Rated input current [A] *8             | LD  | Without DC reactor | 1.9       | 3.0                | 5.1       | 8.2         | 13.0        | 16.0        | 26.0        | 37.0        | 49.0        | 74.3        | 90.5         | 112.9 | 139.5 |
|   |  | With DC reactor   | 1.3                | 2.0       | 3.5                | 6.0       | 9.6         | 12.0        | 20.0        | 30.0        | 40.0        | 63.6        | 79.9        | 99.0         | 114.3 |       |
|   | ND                                     | Without DC reactor  | 1.4                | 2.3       | 4.5                | 7.0       | 11.0        | 15.0        | 23.0        | 30.0        | 41.0        | 56.0        | 69.0        | 88.0         | 115.0 |       |
|   |  | With DC reactor   | 0.8                | 1.5       | 3.0                | 5.0       | 8.0         | 11.0        | 17.5        | 24.0        | 33.0        | 47.0        | 60.0        | 76.0         | 90.0  |       |
|   | Power supply capacity [kVA] *6         | LD  | Without DC reactor | 0.7       | 1.1                | 1.9       | 3.1         | 4.8         | 6.2         | 9.7         | 14.0        | 19.0        | 29.0        | 35.0         | 43.0  | 54.0  |
|   |  |   | With DC reactor    | 0.5       | 0.8                | 1.3       | 2.3         | 3.7         | 4.6         | 7.5         | 11.0        | 15.0        | 25.0        | 31.0         | 38.0  | 44.0  |
| ND                                      |  | Without DC reactor  | 0.5                | 0.9       | 1.7                | 2.7       | 4.1         | 5.7         | 8.8         | 12.0        | 16.0        | 21.0        | 26.0        | 34.0         | 44.0  |       |
|   |  | With DC reactor   | 0.3                | 0.6       | 1.1                | 1.9       | 3.0         | 4.2         | 6.7         | 9.1         | 13.0        | 18.0        | 23.0        | 29.0         | 34.0  |       |
| Protective structure (IEC 60529) *7     |  | Open type (IP20)  |                    |           |                    |           |             |             |             |             |             |             |             |              |       |       |
| Cooling system                          |  | Natural   |                    |           | Forced air cooling |           |             |             |             |             |             |             |             |              |       |       |
| Weight [kg]                             |  | 0.5   | 0.5                | 0.7       | 1.0                | 1.4       | 1.4         | 1.8         | 3.3         | 3.3         | 5.4         | 5.6         | 11.0        | 11.0         |       |       |

\*1 The applicable motor capacity indicated is the maximum capacity applicable for use of the Mitsubishi Electric 4-pole standard efficiency motor.

To drive a Mitsubishi Electric high-performance energy-saving motor, use the 0.75K inverter for a 1.1 kW motor, or 2.2K inverter for a 3 kW motor.

\*2 The rated output capacity is the value with respect to 230 V output voltage.

\*3 The percentage of the overload current rating is the ratio of the overload current to the inverter's rated output current. For repeated duty, allow time for the inverter and motor to return to or below the temperatures under 100% load.

\*4 The maximum output voltage does not exceed the power supply voltage. The maximum output voltage can be changed within the setting range. The maximum point of the voltage waveform at the output side of the inverter is approximately the power supply voltage multiplied by  $\sqrt{2}$ .

\*5 The amount of braking torque is the average short-term torque (which varies depending on motor loss) that is generated when a motor decelerates in the shortest time by itself from 60 Hz. It is not continuous regenerative torque. The average deceleration torque becomes lower when a motor decelerates from a frequency higher than the base frequency. The inverter is not equipped with a built-in brake resistor. Use an option brake resistor for an operation with large regenerative power (not available for the FR-E820-0008(0.1K) and FR-E820-0015(0.2K)). The brake unit (FR-BU2) can be also used.

\*6 The power supply capacity varies with the value of the input power impedance (including those of the input reactor and cables).

\*7 The value in parentheses is the rated output current when the low acoustic noise operation is performed with the surrounding air temperature exceeding 40°C while 2 kHz or higher value is selected in **Pr.72 PWM frequency selection**.

\*8 The rated input current is the value at a rated output voltage. The input power impedances (including those of the input reactor and cables) affect the value.

\*9 Connect the DC power supply to the inverter terminals P/+ and N/-. Connect the positive terminal of the power supply to terminal P/+ and the negative terminal to terminal N/-.

When the energy is regenerated from the motor, the voltage between terminals P/+ and N/- may temporarily rise to 415 V or more. Use a DC power supply resistant to the regenerative voltage/energy. When a power supply that cannot resist the regenerative voltage/energy is used, connect a reverse current prevention diode in series.

Powering ON produces up to four times as large current as the inverter rated current. Prepare a DC power supply resistant to the inrush current at power ON, although an inrush current limit circuit is provided in the FR-E800 series inverter.

The power capacity depends on the output impedance of the power supply. Select a power capacity around the AC power supply capacity.



### 8.1.2 Three-phase 400 V power supply

| Model FR-E840-□                         |  | 0016  | 0026         | 0040         | 0060               | 0095          | 0120           | 0170           | 0230           | 0300           | 0380           | 0440           |      |
|---|--|---|--------------|--------------|--------------------|---------------|----------------|----------------|----------------|----------------|----------------|----------------|------|
|   |  | 0.4K  | 0.75K        | 1.5K         | 2.2K               | 3.7K          | 5.5K           | 7.5K           | 11K            | 15K            | 18.5K          | 22K            |      |
| Applicable motor capacity [kW] *1       | LD                                     | 0.75  | 1.5          | 2.2          | 3.0                | 5.5           | 7.5            | 11.0           | 15.0           | 18.5           | 22.0           | 30.0           |      |
|   | ND                                     | 0.4   | 0.75         | 1.5          | 2.2                | 3.7           | 5.5            | 7.5            | 11.0           | 15.0           | 18.5           | 22.0           |      |
| Rated capacity [kVA] *2                 | LD                                     | 1.6   | 2.7          | 4.2          | 5.3                | 8.5           | 13.3           | 17.5           | 26.7           | 31.2           | 34.3           | 45.7           |      |
|   | ND                                     | 1.2   | 2.0          | 3.0          | 4.6                | 7.2           | 9.1            | 13.0           | 17.5           | 22.9           | 29.0           | 33.5           |      |
| Rated current [A] *7                    | LD                                     | 2.1<br>(1.8)  | 3.5<br>(3.0) | 5.5<br>(4.7) | 6.9<br>(5.9)       | 11.1<br>(9.4) | 17.5<br>(14.9) | 23.0<br>(19.6) | 35.0<br>(29.8) | 41.0<br>(34.9) | 45.0<br>(38.3) | 60.0<br>(51.0) |      |
|   | ND                                     | 1.6<br>(1.4)  | 2.6<br>(2.2) | 4.0<br>(3.8) | 6.0<br>(5.4)       | 9.5<br>(8.7)  | 12.0           | 17.0           | 23.0           | 30.0           | 38.0           | 44.0           |      |
| Overload current rating *3              | LD                                     | 120% 60 s, 150% 3 s (inverse-time characteristics) at surrounding air temperature of 50°C |              |              |                    |               |                |                |                |                |                |                |      |
|   | ND                                     | 150% 60 s, 200% 3 s (inverse-time characteristics) at surrounding air temperature of 50°C |              |              |                    |               |                |                |                |                |                |                |      |
| Rated voltage *4                        |  | Three-phase 380 to 480 V  |              |              |                    |               |                |                |                |                |                |                |      |
| Regenerative braking                    | Brake transistor                       | Built-in  |              |              |                    |               |                |                |                |                |                |                |      |
|   | Maximum brake torque (ND reference) *5 | 100%  |              | 50%          |                    | 20%           |                |                |                |                |                |                |      |
| Rated input AC (DC) voltage/frequency   |  | Three-phase 380 to 480 V, 50/60 Hz (537 to 679 VDC*9)                                     |              |              |                    |               |                |                |                |                |                |                |      |
| Permissible AC (DC) voltage fluctuation |  | 323 to 528 V, 50/60 Hz (457 to 740 VDC*9)   |              |              |                    |               |                |                |                |                |                |                |      |
| Permissible frequency fluctuation       |  | ±5%   |              |              |                    |               |                |                |                |                |                |                |      |
| Rated input current [A] *8              | LD                                     | Without DC reactor  | 3.3          | 6.0          | 8.9                | 11.0          | 16.0           | 25.0           | 32.0           | 46.7           | 54.2           | 59.1           | 75.6 |
|   |  | With DC reactor   | 2.1          | 3.5          | 5.5                | 6.9           | 11.0           | 18.0           | 23.0           | 32.1           | 41.0           | 50.8           | 57.3 |
|   | ND                                     | Without DC reactor  | 2.7          | 4.4          | 6.7                | 9.5           | 14.0           | 18.0           | 25.0           | 35.0           | 41.0           | 45.0           | 60.0 |
|   |  | With DC reactor   | 1.6          | 2.6          | 4.0                | 6.0           | 9.5            | 12.0           | 17.0           | 23.0           | 30.0           | 38.0           | 44.0 |
| Power supply capacity [kVA] *6          | LD                                     | Without DC reactor  | 2.5          | 4.5          | 6.8                | 8.2           | 12.0           | 19.0           | 25.0           | 36.0           | 42.0           | 45.0           | 58.0 |
|   |  | With DC reactor   | 1.6          | 2.7          | 4.2                | 5.3           | 8.5            | 13.0           | 18.0           | 25.0           | 32.0           | 39.0           | 44.0 |
|   | ND                                     | Without DC reactor  | 2.1          | 3.4          | 5.1                | 7.2           | 11.0           | 14.0           | 19.0           | 27.0           | 31.0           | 34.0           | 46.0 |
|   |  | With DC reactor   | 1.2          | 2.0          | 3.0                | 4.6           | 7.2            | 9.1            | 13.0           | 18.0           | 23.0           | 29.0           | 34.0 |
| Protective structure (IEC 60529) *7     |  | Open type (IP20)  |              |              |                    |               |                |                |                |                |                |                |      |
| Cooling system                          |  | Natural   |              |              | Forced air cooling |               |                |                |                |                |                |                |      |
| Weight [kg]                             |  | 1.2   | 1.2          | 1.4          | 1.8                | 1.8           | 2.4            | 2.4            | 4.8            | 4.9            | 11.0           | 11.0           |      |

\*1 The applicable motor capacity indicated is the maximum capacity applicable for use of the Mitsubishi Electric 4-pole standard efficiency motor.

To drive a Mitsubishi Electric high-performance energy-saving motor, use the 2.2K inverter for a 3 kW motor.

\*2 The rated output capacity is the value with respect to 440 V output voltage.

\*3 The percentage of the overload current rating is the ratio of the overload current to the inverter's rated output current. For repeated duty, allow time for the inverter and motor to return to or below the temperatures under 100% load.

\*4 The maximum output voltage does not exceed the power supply voltage. The maximum output voltage can be changed within the setting range. The maximum point of the voltage waveform at the output side of the inverter is approximately the power supply voltage multiplied by  $\sqrt{2}$ .

\*5 The amount of braking torque is the average short-term torque (which varies depending on motor loss) that is generated when a motor decelerates in the shortest time by itself from 60 Hz. It is not continuous regenerative torque. The average deceleration torque becomes lower when a motor decelerates from a frequency higher than the base frequency. The inverter is not equipped with a built-in brake resistor. Use an option brake resistor for an operation with large regenerative power. The brake unit (FR-BU2) can be also used.

\*6 The power supply capacity varies with the value of the input power impedance (including those of the input reactor and cables).

\*7 The value in parentheses is the rated output current when the low acoustic noise operation is performed with the surrounding air temperature exceeding 40°C while 2 kHz or higher value is selected in **Pr.72 PWM frequency selection**.

\*8 The rated input current is the value at a rated output voltage. The input power impedances (including those of the input reactor and cables) affect the value.

\*9 Connect the DC power supply to the inverter terminals P/+ and N/-. Connect the positive terminal of the power supply to terminal P/+ and the negative terminal to terminal N/-.

When the energy is regenerated from the motor, the voltage between terminals P/+ and N/- may temporarily rise to 830 V or more. Use a DC power supply resistant to the regenerative voltage/energy. When a power supply that cannot resist the regenerative voltage/energy is used, connect a reverse current prevention diode in series.

Powering ON produces up to four times as large current as the inverter rated current. Prepare a DC power supply resistant to the inrush current at power ON, although an inrush current limit circuit is provided in the FR-E800 series inverter.

The power capacity depends on the output impedance of the power supply. Select a power capacity around the AC power supply capacity.

**8.1.3 Single-phase 200 V power supply**

| Model FR-E820S-□                    |                                    | 0008                                | 0015  | 0030      | 0050      | 0080               | 0110      |             |      |
|-------------------------------------|------------------------------------|-------------------------------------|---|-----------|-----------|--------------------|-----------|-------------|------|
|                                     |                                    | 0.1K                                | 0.2K  | 0.4K      | 0.75K     | 1.5K               | 2.2K      |             |      |
| Applicable motor capacity [kW] *1   | ND                                 | 0.1                                 | 0.2   | 0.4       | 0.75      | 1.5                | 2.2       |             |      |
| Output                              | Rated capacity [kVA] *2            | ND                                  | 0.3   | 0.6       | 1.2       | 2.0                | 3.2       | 4.4         |      |
|                                     | Rated current [A] *7               | ND                                  | 0.8 (0.8)   | 1.5 (1.4) | 3.0 (2.5) | 5.0 (4.1)          | 8.0 (7.0) | 11.0 (10.0) |      |
|                                     | Overload current rating *3         | ND                                  | 150% 60 s, 200% 3 s (inverse-time characteristics) at surrounding air temperature of 50°C |           |           |                    |           |             |      |
|                                     | Rated voltage *4                   | Single-phase 200 to 240 V           |   |           |           |                    |           |             |      |
|                                     | Regenerative braking               | Brake transistor                    | Not used  |           | Built-in  |                    |           |             |      |
|                                     | Maximum brake torque *5            | 150%                                |   | 100%      |           | 50%                | 20%       |             |      |
| Power supply                        | Rated input AC voltage/frequency   | Single-phase 200 to 240 V, 50/60 Hz |   |           |           |                    |           |             |      |
|                                     | Permissible AC voltage fluctuation | 170 to 264 V, 50/60 Hz              |   |           |           |                    |           |             |      |
|                                     | Permissible frequency fluctuation  | ±5%                                 |   |           |           |                    |           |             |      |
|                                     | Rated input current [A] *8         | ND                                  | Without DC reactor  | 2.3       | 4.1       | 7.9                | 11.2      | 17.9        | 25.0 |
|                                     |                                    |                                     | With DC reactor   | 1.4       | 2.6       | 5.2                | 8.7       | 13.9        | 19.1 |
|                                     | Power supply capacity [kVA] *6     | ND                                  | Without DC reactor  | 0.5       | 0.9       | 1.7                | 2.5       | 3.9         | 5.5  |
|                                     |                                    | With DC reactor                     | 0.3   | 0.6       | 1.1       | 1.9                | 3.0       | 4.2         |      |
| Protective structure (IEC 60529) *7 | Open type (IP20)                   |                                     |   |           |           |                    |           |             |      |
| Cooling system                      | Natural                            |                                     |   |           |           | Forced air cooling |           |             |      |
| Weight [kg]                         |                                    | 0.5                                 | 0.5   | 0.8       | 1.3       | 1.4                | 1.9       |             |      |

\*1 The applicable motor capacity indicated is the maximum capacity applicable for use of the Mitsubishi Electric 4-pole standard efficiency motor.

\*2 The rated output capacity is the value with respect to 230 V output voltage.

\*3 The percentage of the overload current rating is the ratio of the overload current to the inverter's rated output current. For repeated duty, allow time for the inverter and motor to return to or below the temperatures under 100% load. For single-phase power input model, the bus voltage decreases to power failure detection level and the load of 100% or higher may not be available if the automatic restart after instantaneous power failure function (**Pr.57**) or the power failure stop function (**Pr.261**) is set and power supply voltage is low while the load increases.

\*4 The maximum output voltage does not exceed the power supply voltage. The maximum output voltage can be changed within the setting range. The maximum point of the voltage waveform at the output side of the inverter is approximately the power supply voltage multiplied by  $\sqrt{2}$ .

\*5 The amount of braking torque is the average short-term torque (which varies depending on motor loss) that is generated when a motor decelerates in the shortest time by itself from 60 Hz. It is not continuous regenerative torque. The average deceleration torque becomes lower when a motor decelerates from a frequency higher than the base frequency. The inverter is not equipped with a built-in brake resistor. Use an option brake resistor for an operation with large regenerative power (not available for the FR-E820S-0008(0.1K) and FR-E820S-0015(0.2K)). The brake unit (FR-BU2) can be also used.

\*6 The power supply capacity varies with the value of the input power impedance (including those of the input reactor and cables).

\*7 The value in parentheses is the rated output current when the low acoustic noise operation is performed with the surrounding air temperature exceeding 40°C while 2 kHz or higher value is selected in **Pr.72 PWM frequency selection**.

\*8 The rated input current is the value at a rated output voltage. The input power impedances (including those of the input reactor and cables) affect the value.



## 8.2 Outline dimensions

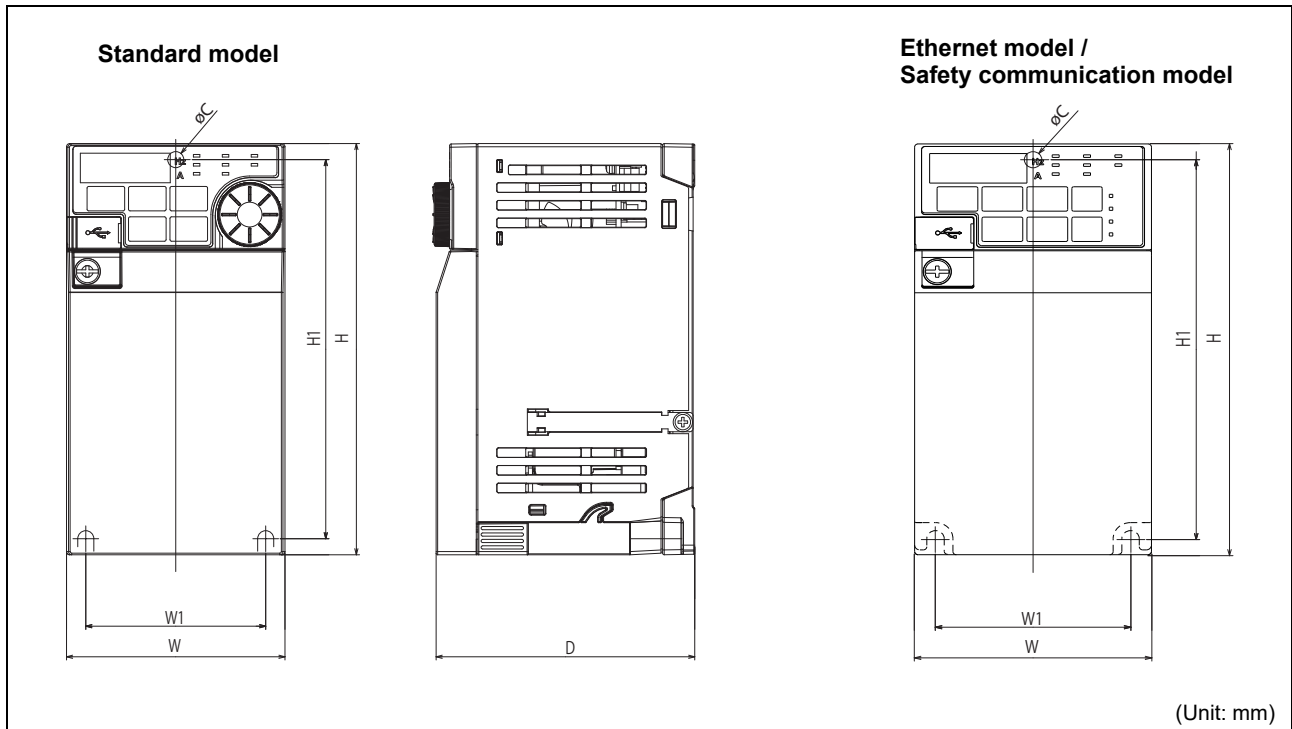

| Inverter Type     |  | W   | W1  | H   | H1  | D     | C |
|-------------------|--|-----|-----|-----|-----|-------|---|
| 200V class Single | FR-E820S-0008(0.1K)<br>FR-E820S-0008(0.1K)E<br>FR-E820S-0008(0.1K)SCE    | 68  | 56  | 128 | 118 | 80.5  | 5 |
|                   | FR-E820S-0015(0.2K)<br>FR-E820S-0015(0.2K)E<br>FR-E820S-0015(0.2K)SCE    |     |     |     |     | 142.5 |   |
|                   | FR-E820S-0030(0.4K)<br>FR-E820S-0030(0.4K)E<br>FR-E820S-0030(0.4K)SCE    | 108 | 96  |     |     | 135   |   |
|                   | FR-E820S-0050(0.75K)<br>FR-E820S-0050(0.75K)E<br>FR-E820S-0050(0.75K)SCE |     |     |     |     | 161   |   |
|                   | FR-E820S-0080(1.5K)<br>FR-E820S-0080(1.5K)E<br>FR-E820S-0080(1.5K)SCE    |     |     |     |     | 142.5 |   |
|                   | FR-E820S-0110(2.2K)<br>FR-E820S-0110(2.2K)E<br>FR-E820S-0110(2.2K)SCE    | 140 | 128 |     |     |       |   |

|   | Inverter Type   | W     | W1  | H   | H1  | D     | C     |     |     |  |
|---|---|-------|-----|-----|-----|-------|-------|-----|-----|--|
| 200V class  | FR-E820-0008(0.1K)<br>FR-E820-0008(0.1K)E<br>FR-E820-0008(0.1K)SCE    | 68    | 56  | 128 | 118 | 80.5  | 5     |     |     |  |
|   | FR-E820-0015(0.2K)<br>FR-E820-0015(0.2K)E<br>FR-E820-0015(0.2K)SCE    |       |     |     |     | 112.5 |       |     |     |  |
|   | FR-E820-0030(0.4K)<br>FR-E820-0030(0.4K)E<br>FR-E820-0030(0.4K)SCE    |       |     |     |     | 132.5 |       |     |     |  |
|   | FR-E820-0050(0.75K)<br>FR-E820-0050(0.75K)E<br>FR-E820-0050(0.75K)SCE | 135.5 |     |     |     |       |       |     |     |  |
|   | FR-E820-0080(1.5K)<br>FR-E820-0080(1.5K)E<br>FR-E820-0080(1.5K)SCE    | 108   | 96  |     |     |       | 142.5 |     |     |  |
|   | FR-E820-0110(2.2K)<br>FR-E820-0110(2.2K)E<br>FR-E820-0110(2.2K)SCE    |       |     |     |     |       |       |     |     |  |
|   | FR-E820-0175(3.7K)<br>FR-E820-0175(3.7K)E<br>FR-E820-0175(3.7K)SCE    | 140   | 128 |     |     |       |       |     |     |  |
|   | FR-E820-0240(5.5K)<br>FR-E820-0240(5.5K)E<br>FR-E820-0240(5.5K)SCE    | 180   | 164 | 260 | 244 | 165   | 6     |     |     |  |
|   | FR-E820-0330(7.5K)<br>FR-E820-0330(7.5K)E<br>FR-E820-0330(7.5K)SCE    |       |     |     |     |       |       |     |     |  |
|   | FR-E820-0470(11K)<br>FR-E820-0470(11K)E<br>FR-E820-0470(11K)SCE       | 220   |     | 195 | 260 | 244   | 190   | 6   |     |  |
|   | FR-E820-0600(15K)<br>FR-E820-0600(15K)E<br>FR-E820-0600(15K)SCE       |       |     |     |     |       |       |     |     |  |
|   | FR-E820-0760(18.5K)<br>FR-E820-0760(18.5K)E<br>FR-E820-0760(18.5K)SCE |       |     |     |     |       | 200   | 350 | 330 |  |
| FR-E820-0900(22K)<br>FR-E820-0900(22K)E<br>FR-E820-0900(22K)SCE |   |       |     |     |     |       |       |     |     |  |
| 400V class  | FR-E840-0016(0.4K)<br>FR-E840-0016(0.4K)E<br>FR-E840-0016(0.4K)SCE    | 108   | 96  | 128 | 118 | 129.5 | 5     |     |     |  |
|   | FR-E840-0026(0.75K)<br>FR-E840-0026(0.75K)E<br>FR-E840-0026(0.75K)SCE |       |     |     |     |       |       |     |     |  |
|   | FR-E840-0040(1.5K)<br>FR-E840-0040(1.5K)E<br>FR-E840-0040(1.5K)SCE    |       |     |     |     |       |       |     |     |  |
|   | FR-E840-0060(2.2K)<br>FR-E840-0060(2.2K)E<br>FR-E840-0060(2.2K)SCE    | 140   | 128 |     | 135 |       |       |     |     |  |
|   | FR-E840-0095(3.7K)<br>FR-E840-0095(3.7K)E<br>FR-E840-0095(3.7K)SCE    |       |     | 150 | 138 |       | 147   |     |     |  |
|   | FR-E840-0120(5.5K)<br>FR-E840-0120(5.5K)E<br>FR-E840-0120(5.5K)SCE    |       |     |     |     |       |       |     |     |  |
|   | FR-E840-0170(7.5K)<br>FR-E840-0170(7.5K)E<br>FR-E840-0170(7.5K)SCE    | 220   |     | 208 | 260 | 244   | 6     |     |     |  |
|   | FR-E840-0230(11K)<br>FR-E840-0230(11K)E<br>FR-E840-0230(11K)SCE       |       |     |     |     |       |       |     |     |  |
|   | FR-E840-0300(15K)<br>FR-E840-0300(15K)E<br>FR-E840-0300(15K)SCE       |       |     |     |     |       | 190   |     |     |  |
|   | FR-E840-0380(18.5K)<br>FR-E840-0380(18.5K)E<br>FR-E840-0380(18.5K)SCE |       |     |     |     |       |       |     |     |  |
| FR-E840-0440(22K)<br>FR-E840-0440(22K)E<br>FR-E840-0440(22K)SCE |   | 200   | 350 | 330 |     | 10    |       |     |     |  |



---

---

# A APPENDIX

---

---

## A.1 Instructions for Compliance with the EU Directives

---

The EU Directives are issued to standardize different national regulations of the EU Member States and to facilitate free movement of the equipment, whose safety is ensured, in the EU territory.

Since 1996, compliance with the EMC Directive that is one of the EU Directives has been legally required. Since 1997, compliance with the Low Voltage Directive, another EU Directive, has been also legally required. When a manufacturer confirms its equipment to be compliant with the EMC Directive and the Low Voltage Directive, the manufacturer must declare the conformity and affix the CE marking.

- The authorized representative in the EU  
The authorized representative in the EU is shown below:  
Name: Mitsubishi Electric Europe B.V.  
Address: Mitsubishi-Electric-Platz 1, 40882 Ratingen, Germany

### A.1.1 EMC Directive

We declare that this inverter conforms with the EMC Directive and affix the CE marking on the inverter.

- EMC Directive: 2014/30/EU
- Standard(s): EN61800-3:2004+A1:2012 (Second environment / PDS Category "C3")
- This inverter is not intended to be used on a low-voltage public network which supplies domestic premises. When using the inverter in a residential area, take appropriate measures and ensure the conformity of the inverter used in the residential area.
- Radio frequency interference is expected if used on such a network.
- The installer shall provide a guide for installation and use, including recommended mitigation devices.

#### NOTES

- First environment  
Environment including residential buildings. Includes buildings directly connected without a transformer to the low voltage power supply network which supplies power to residential buildings.
- Second environment  
Environment including all buildings except buildings directly connected without a transformer to the low voltage power supply network which supplies power to residential buildings.

#### NOTES

- Set the EMC Directive compliant EMC filter to the inverter. Insert line noise filters and ferrite cores to the power and control cables as required.
- Connect the inverter to an earthed power supply.
- Install a motor and a control cable according to the EMC Installation Guidelines (BCN-A21041-204) and Technical News (MF-S-114, 115) according to the instruction.
- To make full use of the EMC Directive compliant noise filter, motor cable lengths should not exceed 20 m.
- Ensure that the finalized system which includes an inverter complies with the EMC Directive.



## A.1.2 Low Voltage Directive

We have self-confirmed our inverters as products compliant to the Low Voltage Directive 2014/35/EU (conforming standard EN 61800-5-1) and place the CE mark on the inverters.

### Outline of instructions

- Do not use an earth leakage current breaker as an electric shock protector without connecting the equipment to the earth. Connect the equipment to the earth securely.
- Wire the earth terminal independently. (Do not connect two or more cables to one terminal.)
- Use the cable sizes on *page 17* under the following conditions.
  - Surrounding air temperature: 40°C maximum
  - If conditions are different from above, select appropriate wire according to EN60204 Appendix C TABLE 5.
- Use a tinned (plating should not include zinc) crimping terminal to connect the earth cable. When tightening the screw, be careful not to damage the threads.  
For use as a product compliant with the Low Voltage Directive, use PVC cable whose size is indicated on *page 17*.
- Use the moulded case circuit breaker and magnetic contactor which conform to the EN or IEC Standard.
- This product can cause a DC current in the protective earthing conductor. Where a residual current-operated protective (RCD) or monitoring (RCM) device is used for protection in case of direct or indirect contact, only an RCD or RCM of Type B is allowed on the supply side of this product.
- Use the inverter under the conditions of overvoltage category III specified in IEC 60664.
- To use the inverter under the conditions of pollution degree 3, install it in the enclosure of IP54 or higher.

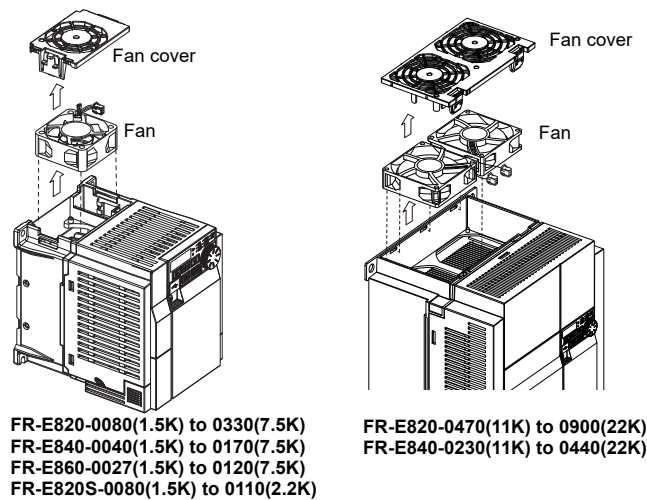

If the cover is not fixed, the inverter protective structure is regarded as IP00.

## A.2 Instructions for UL and cUL

(Conforming standard UL 61800-5-1, CSA C22.2 No.14)

### A.2.1 General precautions

#### **WARNING**

The bus capacitor discharge time is 10 minutes. Before starting wiring or inspection, switch power off, wait for more than 10 minutes, and check for residual voltage between terminal P/+ and N/- with a meter etc., to avoid a hazard of electrical shock.

### A.2.2 Product handling information / Informations sur la manipulation du produit

#### **WARNING**

Operation of this product requires detailed installation and operation instructions provided in this Safety Guideline and the Instruction Manual (Connection) intended for use with this product. Please forward relevant manuals to the end user. The manuals can also be downloaded in PDF form from the Mitsubishi Electric FA Global Website. To order manuals, please contact your sales representative.

### A.2.3 Branch circuit protection

For installation in the United States, branch circuit protection must be provided in accordance with the National Electrical Code and any applicable provincial codes. For installation in Canada, branch circuit protection must be provided in accordance with the Canadian Electrical Code and any applicable provincial codes. Short circuit protection of the inverter cannot be used as branch circuit protection. Integral solid state short circuit protection does not provide branch circuit protection. Branch circuit protection must be provided in accordance with the National Electrical Code and any additional local code.

- Precautions for opening the branch-circuit protective device

#### **WARNING**

If the fuse melts down or the breaker trips on the input side of this product, check for wiring faults (such as short circuits). Identify and remove the cause of melting down or the trip before replacing the fuse or resetting the tripped breaker (or before applying the power to the inverter again).



• Fuse selection

For installation in the United States, the semiconductor fuses shown in the following table must be provided, in accordance with the National Electrical Code and any applicable local codes. For installation in Canada, the semiconductor fuses shown in the following table must be provided, in accordance with the Canadian Electrical Code and any applicable local codes. The following semiconductor fuses cannot be used as branch circuit protection. For branch circuit protection, use appropriate fuses or install a breaker.

**Standard model/Ethernet model**

| Inverter model                 | Cat. No                        | Manufacturer | Rating       |
|--------------------------------|--------------------------------|--------------|--------------|
| FR-E820-0008(0.1K), 0015(0.2K) | 170M1408, 170M1308 or 170M1358 | Bussmann     | 700 V, 10 A  |
| FR-E820-0030(0.4K)             | 170M1409, 170M1309 or 170M1359 | Bussmann     | 700 V, 16 A  |
| FR-E820-0050(0.75K)            | 170M1411, 170M1311 or 170M1361 | Bussmann     | 700 V, 25 A  |
| FR-E820-0080(1.5K)             | 170M1413, 170M1313 or 170M1363 | Bussmann     | 700 V, 40 A  |
| FR-E820-0110(2.2K)             | 170M1414, 170M1314 or 170M1364 | Bussmann     | 700 V, 50 A  |
| FR-E820-0175(3.7K)             | 170M1416, 170M1316 or 170M1366 | Bussmann     | 700 V, 80 A  |
| FR-E820-0240(5.5K)             | 170M1418, 170M1318 or 170M1368 | Bussmann     | 700 V, 125 A |
| FR-E820-0330(7.5K)             | 170M1419, 170M1319 or 170M1369 | Bussmann     | 700 V, 160 A |
| FR-E820-0470(11)               | 170M1420, 170M1320 or 170M1370 | Bussmann     | 700 V, 200 A |
| FR-E820-0600(15K)              | 170M1421, 170M1321 or 170M1471 | Bussmann     | 700 V, 250 A |
| FR-E820-0760(18.5K)            | 170M1422, 170M1322 or 170M1472 | Bussmann     | 700 V, 315 A |
| FR-E820-0900(22K)              | 170M1422, 170M1322 or 170M1472 | Bussmann     | 700 V, 315 A |
| FR-E840-0016(0.4K)             | 170M1408                       | Bussmann     | 700 V, 10 A  |
| FR-E840-0026(0.75K)            | 170M1410                       | Bussmann     | 700 V, 20 A  |

| Inverter model                 | Cat. No                        | Manufacturer | Rating       |
|--------------------------------|--------------------------------|--------------|--------------|
| FR-E840-0040(1.5K)             | 170M1411                       | Bussmann     | 700 V, 25 A  |
| FR-E840-0060(2.2K)             | 170M1412                       | Bussmann     | 700 V, 32 A  |
| FR-E840-0095(3.7K)             | 170M1414                       | Bussmann     | 700 V, 50 A  |
| FR-E840-0120(5.5K), 0170(7.5K) | 170M1416                       | Bussmann     | 700 V, 80 A  |
| FR-E840-0230(11K)              | 170M1419, 170M1319 or 170M1469 | Bussmann     | 700 V, 160 A |
| FR-E840-0300(15K)              | 170M1419, 170M1319 or 170M1469 | Bussmann     | 700 V, 160 A |
| FR-E840-0380(18.5K)            | 170M1420, 170M1320 or 170M1370 | Bussmann     | 700 V, 200 A |
| FR-E840-0440(22K)              | 170M1421, 170M1321 or 170M1471 | Bussmann     | 700 V, 250 A |
| FR-E820S-0008(0.1K)            | 170M1408                       | Bussmann     | 700 V, 10 A  |
| FR-E820S-0015(0.2K)            | 170M1409                       | Bussmann     | 700 V, 16 A  |
| FR-E820S-0030(0.4K)            | 170M1411                       | Bussmann     | 700 V, 25 A  |
| FR-E820S-0050(0.75K)           | 170M1413                       | Bussmann     | 700 V, 40 A  |
| FR-E820S-0080(1.5K)            | 170M1415                       | Bussmann     | 700 V, 63 A  |
| FR-E820S-0110(2.2K)            | 170M1417                       | Bussmann     | 700 V, 100 A |

### Safety communication model

| Inverter model                     | Cat. No                              | Manufacturer | Rating       |
|------------------------------------|--------------------------------------|--------------|--------------|
| FR-E820-0008(0.1K),<br>0015(0.2K)  | 170M1408,<br>170M1308 or<br>170M1358 | Bussmann     | 700 V, 10 A  |
| FR-E820-0030(0.4K)                 | 170M1409,<br>170M1309 or<br>170M1359 | Bussmann     | 700 V, 16 A  |
| FR-E820-0050(0.75K)                | 170M1411,<br>170M1311 or<br>170M1361 | Bussmann     | 700 V, 20 A  |
| FR-E820-0080(1.5K)                 | 170M1413,<br>170M1313 or<br>170M1363 | Bussmann     | 700 V, 32 A  |
| FR-E820-0110(2.2K)                 | 170M1414,<br>170M1314 or<br>170M1364 | Bussmann     | 700 V, 50 A  |
| FR-E820-0175(3.7K)                 | 170M1416,<br>170M1316 or<br>170M1366 | Bussmann     | 700 V, 80 A  |
| FR-E820-0240(5.5K)                 | 170M1418,<br>170M1318 or<br>170M1368 | Bussmann     | 700 V, 100 A |
| FR-E820-0330(7.5K)                 | 170M1419,<br>170M1319 or<br>170M1369 | Bussmann     | 700 V, 160 A |
| FR-E820-0470(11)                   | 170M1420,<br>170M1320 or<br>170M1370 | Bussmann     | 700 V, 200 A |
| FR-E820-0600(15K)                  | 170M1421,<br>170M1321 or<br>170M1471 | Bussmann     | 700 V, 250 A |
| FR-E820-0760(18.5K)                | 170M1422,<br>170M1322 or<br>170M1472 | Bussmann     | 700 V, 315 A |
| FR-E820-0900(22K)                  | 170M1422,<br>170M1322 or<br>170M1472 | Bussmann     | 700 V, 315 A |
| FR-E840-0016(0.4K)                 | 170M1408                             | Bussmann     | 700 V, 10 A  |
| FR-E840-0026(0.75K),<br>0040(1.5K) | 170M1409                             | Bussmann     | 700 V, 16 A  |

| Inverter model       | Cat. No                              | Manufacturer | Rating       |
|----------------------|--------------------------------------|--------------|--------------|
| FR-E840-0060(2.2K)   | 170M1312                             | Bussmann     | 700 V, 32 A  |
| FR-E840-0095(3.7K)   | 170M1413                             | Bussmann     | 700 V, 40 A  |
| FR-E840-0120(5.5K)   | 170M1414                             | Bussmann     | 700 V, 50 A  |
| FR-E840-0170(7.5K)   | 170M1416                             | Bussmann     | 700 V, 80 A  |
| FR-E840-0230(11K)    | 170M1419,<br>170M1319 or<br>170M1469 | Bussmann     | 700 V, 160 A |
| FR-E840-0300(15K)    | 170M1419,<br>170M1319 or<br>170M1469 | Bussmann     | 700 V, 160 A |
| FR-E840-0380(18.5K)  | 170M1420,<br>170M1320 or<br>170M1370 | Bussmann     | 700 V, 200 A |
| FR-E840-0440(22K)    | 170M1421,<br>170M1321 or<br>170M1471 | Bussmann     | 700 V, 250 A |
| FR-E820S-0008(0.1K)  | 170M1408                             | Bussmann     | 700 V, 10 A  |
| FR-E820S-0015(0.2K)  | 170M1409                             | Bussmann     | 700 V, 16 A  |
| FR-E820S-0030(0.4K)  | 170M1411                             | Bussmann     | 700 V, 25 A  |
| FR-E820S-0050(0.75K) | 170M1413                             | Bussmann     | 700 V, 40 A  |
| FR-E820S-0080(1.5K)  | 170M1415                             | Bussmann     | 700 V, 63 A  |
| FR-E820S-0110(2.2K)  | 170M1417                             | Bussmann     | 700 V, 100 A |

### A.2.4 Capacitor discharge time

#### CAUTION

- Risk of Electric Shock

Before wiring or inspection, check that the LED display of the operation panel is OFF. Any person who is involved in wiring or inspection shall wait for 10 minutes or longer after power OFF, and check that there are no residual voltage using a digital multimeter or the like. The capacitor is charged with high voltage for some time after power OFF, and it is dangerous.



## A.2.5 Wiring of the power supply and motor

Refer to the National Electrical Code (Article 310) regarding the allowable current of the cable. Select the cable size for 125% of the rated current according to the National Electrical Code (Article 430). For wiring the input (R/L1, S/L2, T/L3) and output (U, V, W) terminals of the inverter, use the UL listed copper, stranded wires (rated at 75°C) and round crimp terminals. Crimp the terminals with the crimping tool recommended by the terminal manufacturer.

The following table shows examples when the inverter rating is the LD rating, when the cable is the THHW cable with continuous maximum permissible temperature of 75°C, when the surrounding air temperature is 30°C or less, and the wiring length is 20 m or shorter.

| Inverter model                    | Terminal screw size <sup>*1</sup> | Tightening torque (N·m) | Crimp terminal   |         | Cable gauge      |         |
|-----------------------------------|-----------------------------------|-------------------------|------------------|---------|------------------|---------|
|                                   |                                   |                         | R/L1, S/L2, T/L3 | U, V, W | AWG              |         |
|                                   |                                   |                         |                  |         | R/L1, S/L2, T/L3 | U, V, W |
| FR-E820-0008(0.1K) to 0050(0.75K) | M3.5                              | 1.2                     | 2-3.5            | 2-3.5   | 14               | 14      |
| FR-E820-0080(1.5K)                | M4                                | 1.5                     | 3.5-4            | 2-4     | 12               | 14      |
| FR-E820-0110(2.2K)                | M4                                | 1.5                     | 5.5-4            | 2-4     | 10               | 14      |
| FR-E820-0175(3.7K)                | M4                                | 1.5                     | 8-4              | 5.5-4   | 8                | 10      |
| FR-E820-0240(5.5K)                | M5                                | 2.5                     | 8-5              | 8-5     | 8                | 8       |
| FR-E820-0330(7.5K)                | M5                                | 2.5                     | 14-5             | 8-5     | 6                | 8       |
| FR-E820-0470(11)                  | M5                                | 2.5                     | 14-5             | 14-5    | 4                | 4       |
| FR-E820-0600(15K)                 | M6(M5)                            | 4.4                     | 22-6             | 22-6    | 3                | 3       |
| FR-E820-0760(18.5K)               | M8(M6)                            | 7.8                     | 38-8             | 22-8    | 1                | 2       |
| FR-E820-0900(22K)                 | M8(M6)                            | 7.8                     | 38-8             | 38-8    | 1/0              | 1/0     |
| FR-E840-0016(0.4K) to 0060(2.2K)  | M4                                | 1.5                     | 2-4              | 2-4     | 14               | 14      |
| FR-E840-0095(3.7K)                | M4                                | 1.5                     | 5.5-4            | 2-4     | 10               | 14      |
| FR-E840-0120(5.5K), 0170(7.5K)    | M4                                | 1.5                     | 8-4              | 5.5-4   | 8                | 10      |
| FR-E840-0230(11K)                 | M4                                | 1.5                     | 5.5-4            | 5.5-4   | 6                | 8       |
| FR-E840-0300(15K)                 | M5                                | 2.5                     | 8-5              | 8-5     | 4                | 6       |
| FR-E840-0380(18.5K)               | M6                                | 4.4                     | 14-6             | 8-6     | 4                | 6       |
| FR-E840-0440(22K)                 | M6                                | 4.4                     | 14-6             | 14-6    | 3                | 4       |
| FR-E820S-0008(0.1K) to 0030(0.4K) | M3.5                              | 1.2                     | 2-3.5            | 2-3.5   | 14               | 14      |
| FR-E820S-0050(0.75K)              | M4                                | 1.5                     | 2-4              | 2-4     | 14               | 14      |
| FR-E820S-0080(1.5K)               | M4                                | 1.5                     | 2-4              | 2-4     | 14               | 14      |
| FR-E820S-0110(2.2K)               | M4                                | 1.5                     | 5.5-4            | 2-4     | 12               | 14      |

\*1 The screw size for terminals R/L1, S/L2, T/L3, U, V, W, PR, P/+, N/-, and P1, and the earthing (grounding) terminal is shown.

## A.2.6 Short circuit ratings

- 200V class  
Suitable for use in a circuit capable of delivering not more than 100kA rms symmetrical amperes, 240V maximum.
- 400V class  
Suitable for use in a circuit capable of delivering not more than 100kA rms symmetrical amperes, 480 Y / 277 V maximum.

## A.2.7 Motor overload protection

The following explains the details of the motor overload protection.

When using the electronic thermal relay function as motor overload protection, set the rated motor current to Pr. 9 "Electronic thermal O/L relay".

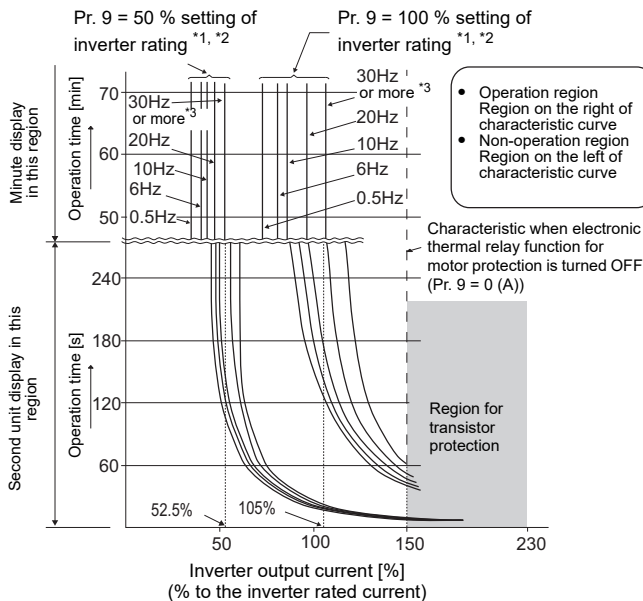

This function detects the overload (overheat) of the motor and shut off the inverter output by stopping the operation of the transistor at the inverter output side. (The operation characteristic is shown on the left.)

When using the Mitsubishi Electric constant-torque motor set one of "10", "13" to "16", "50", "53", "70", "73", "1800" or , "1803" in Pr. 71. (This enables a 100% constant-torque characteristic in the low-speed range.) Set the rated current of the motor in Pr. 9.

\*1 When 50% of the inverter rated output current (current value) is set in Pr. 9.

\*2 The % value denotes the percentage to the inverter rated output current. It is not the percentage to the motor rated current.

\*3 When the electronic thermal relay function dedicated to the Mitsubishi Electric constant-torque motor is set, this characteristic curve applies to operation at 6 Hz or higher.

- The internal accumulated heat value of the electronic thermal O/L relay is reset to the initial value by the inverter's power reset or reset signal input. Avoid unnecessary reset and power-OFF.
- Install an external thermal relay (OCR) between the inverter and motors to operate several motors, a multi-pole motor or a dedicated motor with one inverter.  
When configuring an external thermal relay, note that the current indicated on the motor rating plate is affected by the line-to-line leakage current. (Refer to the Instruction Manual (Function).) The cooling effect of the motor drops during low-speed operation. Use a motor with built-in thermal protector. When the difference between the inverter and motor capacities is large and the set value is small, the protective characteristics of the electronic thermal relay function will be deteriorated. Use an external thermal relay in such cases.
- A dedicated motor cannot be protected by the electronic thermal relay. Use an external thermal relay.
- Motor over temperature sensing is not provided by the drive.

| HEADQUARTERS  |                    | EUROPEAN REPRESENTATIVES  |                               | EUROPEAN REPRESENTATIVES   |                    | EURASIAN REPRESENTATIVES  |                   |
|---|--------------------|---|-------------------------------|--|--------------------|---|-------------------|
| Mitsubishi Electric Europe B.V.<br>Mitsubishi-Electric-Platz 1<br><b>D-40882 Ratingen</b><br>Phone: +49 (0)2102 / 486-2048<br>Fax: +49 (0)2102 / 486-1120   | <b>EUROPE</b>      | GEVA<br>Wiener Straße 89<br><b>A-2500 Baden</b><br>Phone: +43 (0)2252 / 85 55 20<br>Fax: +43 (0)2252 / 488 60                         | <b>AUSTRIA</b>                | INTEHSIS SRL<br>bld. Traian 23/1<br><b>MD-2060 Kishinev</b><br>Phone: +373 (0)22 / 66 4242<br>Fax: +373 (0)22 / 66 4280  | <b>MOLDOVA</b>     | TOO Kazpromavtomatika<br>UL. ZHAMBYLA 28,<br><b>KAZ-100017 Karaganda</b><br>Phone: +7 7212 / 50 10 00<br>Fax: +7 7212 / 50 11 50  | <b>KAZAKHSTAN</b> |
| Mitsubishi Electric Europe B.V.<br>Pekařská 621/7<br><b>CZ-155 00 Praha 5</b><br>Phone: +420 734 402 587<br>Fax: +420 251 551 471   | <b>CZECH REP.</b>  | 000 TECHNIKON<br>Prospect Nezavisimosti 177-9<br><b>BY-220125 Minsk</b><br>Phone: +375 (0)17 / 393 1177<br>Fax: +375 (0)17 / 393 0081 | <b>BELARUS</b>                | Fonseca S.A.<br>R. João Francisco do Casal 87/89<br><b>PT-3801-997 Aveiro, Esigueira</b><br>Phone: +351 (0)234 / 303 900<br>Fax: +351 (0)234 / 303 910         | <b>PORTUGAL</b>    | <b>MIDDLE EAST REPRESENTATIVE</b>   |                   |
| Mitsubishi Electric Europe B.V.<br>25, Boulevard des Bouvets<br><b>F-92741 Nanterre Cedex</b><br>Phone: +33 (0)1 / 55 68 56 95<br>Fax: +33 (0)1 / 55 68 57 57   | <b>FRANCE</b>      | INEA RBT d.o.o.<br>Stegne 11<br><b>SI-1000 Ljubljana</b><br>Phone: +386 (0)1 / 513 8116<br>Fax: +386 (0)1 / 513 8170                  | <b>BOSNIA AND HERZEGOVINA</b> | SIRIUS TRADING & SERVICES SRL<br>Aleea Lacul Morii Nr. 3<br><b>RO-060841 Bucuresti, Sector 6</b><br>Phone: +40 (0)21 / 430 40 06<br>Fax: +40 (0)21 / 430 40 02 | <b>ROMANIA</b>     | EIM Energy<br>3 Roxy Square<br><b>EGYPT</b><br><b>ET-11341 Heliopolis, Cairo</b><br>Phone: +202 24552559<br>Fax: +202 245266116   |                   |
| Mitsubishi Electric Europe B.V.<br>Madarász Irodapark, Madarász Viktor u. 47-49.<br><b>HU-1138 Budapest</b><br>Phone: +36 70 3322 372   | <b>HUNGARY</b>     | AKHNATON<br>4, Andrei Ljapchev Blvd., PO Box 21<br><b>BG-1756 Sofia</b><br>Phone: +359 (0)2 / 817 6000<br>Fax: +359 (0)2 / 97 44 06 1 | <b>BULGARIA</b>               | INEA SR d.o.o.<br>Ul. Karadjordjeva 12/217<br><b>SER-11300 Smederevo</b><br>Phone: +381 69 172 27 25   | <b>SERBIA</b>      | SHERF Motion Techn. Ltd.<br>Rehov Hamerkava 19<br><b>ISRAEL</b><br><b>IL-58851 Holon</b><br>Phone: +972 (0)3 / 559 54 62<br>Fax: +972 (0)3 / 556 01 82                        |                   |
| Mitsubishi Electric Europe B.V.<br>Westgate Business Park, Ballymount<br><b>IRL-Dublin 24</b><br>Phone: +353 (0)1 4198800<br>Fax: +353 (0)1 4198890   | <b>IRELAND</b>     | INEA CR<br>Losinjka 4 a<br><b>HR-10000 Zagreb</b><br>Phone: +385 (0)1 / 36 940 - 01 / -02 / -03<br>Fax: +385 (0)1 / 36 940 - 03       | <b>CROATIA</b>                | SIMAP SK (Západné Slovensko)<br>Dolné Pažite 603/97<br><b>SK-911 06 Trenčín</b><br>Phone: +421 (0)32 743 04 72<br>Fax: +421 (0)32 743 75 20                    | <b>SLOVAKIA</b>    | CEG LIBAN<br>Cebaco Center/Block A Autostrade DORA<br><b>LEBANON</b><br><b>Lebanon-Beirut</b><br>Phone: +961 (0)1 / 240 445<br>Fax: +961 (0)1 / 240 193                       |                   |
| Mitsubishi Electric Europe B.V.<br>Viale Colleoni 7 Palazzo Sirio<br><b>I-20864 Agrate Brianza (MB)</b><br>Phone: +39 039 / 60 53 1<br>Fax: +39 039 / 60 53 12  | <b>ITALY</b>       | SIMAP CZ s.r.o.<br>Nové sady 988/2<br><b>CZ-602 00 Brno</b><br>Phone: +420 777 731 900  | <b>CZECH REPUBLIC</b>         | INEA RBT d.o.o.<br>Stegne 11<br><b>SI-1000 Ljubljana</b><br>Phone: +386 (0)1 / 513 8116<br>Fax: +386 (0)1 / 513 8170   | <b>SLOVENIA</b>    | <b>AFRICAN REPRESENTATIVE</b>   |                   |
| Mitsubishi Electric Europe B.V.<br>Nijverheidsweg 23C<br><b>NL-3641RP Mijdrecht</b><br>Phone: +31 (0) 297 250 350   | <b>NETHERLANDS</b> | HANS FØLSGAARD A/S<br>Theilgaardsgade 1<br><b>DK-4600 Køge</b><br>Phone: +45 4320 8600<br>Fax: +45 4396 8855                          | <b>DENMARK</b>                | OMNI RAY AG<br>Im Schörl 5<br><b>CH-8600 Dübendorf</b><br>Phone: +41 (0)44 / 802 28 80<br>Fax: +41 (0)44 / 802 28 28   | <b>SWITZERLAND</b> | ADROIT TECHNOLOGIES<br>20 Waterford Office Park 189 Witkoppen Road<br><b>SOUTH AFRICA</b><br><b>ZA-Fourways</b><br>Phone: + 27 (0)11 / 658 8100<br>Fax: + 27 (0)11 / 658 8101 |                   |
| Mitsubishi Electric Europe B.V.<br>ul. Krakowska 48<br><b>PL-32-083 Balice</b><br>Phone: +48 (0) 12 347 65 00<br>Fax: +48 (0) 12 630 47 01  | <b>POLAND</b>      | Electrobit OÜ<br>Pärnu mnt. 160i<br><b>EST-11317, Tallinn</b><br>Phone: +372 6518 140   | <b>ESTONIA</b>                | CSC - AUTOMATION Ltd.<br>4 B, Yevhena Sverstyuka Str.<br><b>UA-02002 Kiev</b><br>Phone: +380 (0)44 / 494 33 44<br>Fax: +380 (0)44 / 494-33-66                  | <b>UKRAINE</b>     |   |                   |
| Mitsubishi Electric (Russia) LLC<br>2 bld. 1, Letnikovskaya st.<br><b>RU-115114 Moscow</b><br>Phone: +7 495 / 721 2070<br>Fax: +7 495 / 721 2071  | <b>RUSSIA</b>      | UTU Automation Oy<br>Pelttie 37i<br><b>FIN-28400 Ulvila</b><br>Phone: +358 (0)207 / 463 500<br>Fax: +358 207 / 463 501                | <b>FINLAND</b>                |  |                    |   |                   |
| Mitsubishi Electric Europe B.V.<br>Levická 7<br><b>SK-949 01 Nitra</b><br>Phone: +421 917 624036  | <b>SLOVAKIA</b>    | UTECO A.B.E.E.<br>5, Mavrogenous Str.<br><b>GR-18542 Piraeus</b><br>Phone: +30 (0)211 / 1206-900<br>Fax: +30 (0)211 / 1206-999        | <b>GREECE</b>                 |  |                    |   |                   |
| Mitsubishi Electric Europe B.V.<br>Carretera de Rubí 76-80 Apdo. 420<br><b>E-08190 Sant Cugat del Vallés (Barcelona)</b><br>Phone: +34 (0) 93 / 5653131<br>Fax: +34 (0) 93 / 5891579                                    | <b>SPAIN</b>       | MELTRADE Kft.<br>Fertő utca 14.<br><b>HU-1107 Budapest</b><br>Phone: +36 (0)1 / 431-9726<br>Fax: +36 (0)1 / 431-9727                  | <b>HUNGARY</b>                |  |                    |   |                   |
| Mitsubishi Electric Europe B.V. (Scandinavia)<br>Hedvig Möllers gata 6,<br><b>SE- 223 55 Lund</b><br>Phone: +46 (0) 8 625 10 00   | <b>SWEDEN</b>      | OAK Integrator Products SIA<br>Ritausmas iela 23<br><b>LV-1058 Riga</b><br>Phone: +371 67842280                                       | <b>LATVIA</b>                 |  |                    |   |                   |
| Mitsubishi Electric Turkey Elektrik Ürünleri A.Ş.<br>Fabrika Otomasyonu Merkezi<br>Şerifali Mahallesi Kale Sokak No:41<br><b>TR-34775 Ümraniye-İSTANBUL</b><br>Phone: +90 (216) 969 25 00<br>Fax: +90 (216) / 661 44 47 | <b>TURKEY</b>      | Automatikos Centras, UAB<br>Pramonės pr. 17H<br><b>LT-51327 Kaunas</b><br>Phone: +370 37 262707<br>Fax: +370 37 455605                | <b>LITHUANIA</b>              |  |                    |   |                   |
| Mitsubishi Electric Europe B.V.<br>Travellers Lane<br><b>UK-Hatfield, Herts. AL10 8XB</b><br>Phone: +44 (0)1707 / 28 87 80<br>Fax: +44 (0)1707 / 27 86 95   | <b>UK</b>          | ALFATRADE Ltd.<br>99, Paola Hill<br><b>Malta-Paola PLA 1702</b><br>Phone: +356 (0)21 / 697 816<br>Fax: +356 (0)21 / 697 817           | <b>MALTA</b>                  |  |                    |   |                   |
| Mitsubishi Electric Corporation<br>Tokyo Building 2-7-3<br>Marunouchi, Chiyoda-ku<br><b>Tokyo 100-8310</b><br>Phone: +81 (3) 3218-2111<br>Fax: +81 (3) 3218-2185  | <b>JAPAN</b>       |   |                               |  |                    |   |                   |
| Mitsubishi Electric Automation, Inc.<br>500 Corporate Woods Parkway<br><b>Vernon Hills, IL 60061</b><br>Phone: +1 (847) 478-2100<br>Fax: +1 (847) 478-0328  | <b>USA</b>         |   |                               |  |                    |   |                   |