

# Installation Guide for the INMBSOCP0\*\*0100 Gateway

The order code may vary depending on the product seller and the buyer's location.

\*\* stands for the gateway capacity and varies depending on the specific gateway purchased.

### Owner's record

Find the serial number on the silver label on the right side of the gateway. For sales or technical assistance, we recommend writing it in the space below:

SN:

## Safety Information



Follow these instructions carefully. Improper work may seriously harm your health and damage the gateway and/or any other equipment connected to it.

Only technical personnel, following these instructions and the country legislation for installing electric equipment, can install and manipulate this gateway.

Install this gateway indoors, in a restricted access location, avoiding exposure to direct solar radiation, water, high relative humidity, or dust.

All wires for communication and power supply (if needed) must only be connected to networks without routing to the outside plant. All communication ports are considered for indoor use and must only be connected to SELV circuits.

Mount the gateway, preferably, on a DIN rail inside a grounded metal cabinet following the instructions below.

In the case of wall mounting, firmly fix the gateway on a non-vibrating surface following the instructions below.

Disconnect power wires before manipulating and connecting them to the gateway.

Use SELV-rated NEC class 2 or limited power source (LPS) power supply.

Use a circuit-breaker before the power supply. Rating 250 V, 6 A.

Supply the correct voltage to power the gateway. See the Technical Specifications table at the end of this document.

Respect the expected polarity of power (if needed) and communication cables when connecting them to the gateway.

This gateway is designed for installation inside an enclosure. When working inside an enclosure (ex. to make adjustments, set switches, etc.), observe the common antistatic precautions before manipulating the gateway.

Take precautions when installing it outside an enclosure to avoid electrostatic discharges.

These safety instructions in other languages can be found [here](#).

## Mounting

Mount the gateway over a wall or over a DIN rail.



DIN rail mounting inside a grounded metallic cabinet is recommended.

### Wall mounting

1. Press the rear panel clips outwards until you hear a *click*.
2. Use the clip holes to screw the gateway to the wall.
3. Make sure the gateway is firmly fixed.

### DIN rail mounting

1. Fit the gateway's top-side clips in the upper edge of the DIN rail.
2. Press the low side of the gateway gently to lock it in the DIN rail.
3. Make sure the gateway is firmly fixed.



For some DIN rails, to complete step 2, you may need a small screwdriver or similar to pull the bottom clip down.

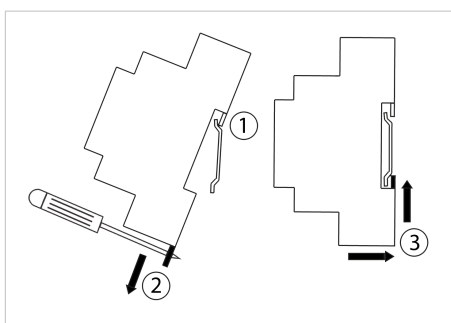

## Wiring

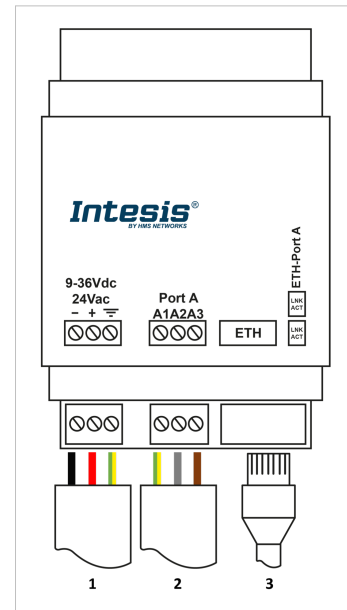

- |                       |                 |                               |
|-----------------------|-----------------|-------------------------------|
| <b>1</b> Power Supply | <b>2</b> Port A | <b>3</b> Ethernet             |
| 9-36 VDC / 24 VAC     | Modbus RTU      | OCPP - Modbus TCP and console |



Disconnect all systems from power before wiring the gateway.

1. Connect the Modbus RTU bus to the EIA-485 port of the gateway.



Observe polarity: **A1**: ground connection, **A2**: negative, **A3**: positive.



Standard EIA-485 bus requirements: maximum distance of 1200 meters (4000 ft); up to 32 devices connected; a 120 Ω resistor at each end of the bus is needed (See the DIP switch section).

2. Connect the OCPP - Modbus TCP cable to the ETH port of the gateway.
  - Use an Ethernet CAT5 or higher cable.
  - If using the building LAN, contact the network administrator and make sure traffic is allowed through all the LAN path.
  - When starting up the gateway for the first time, DHCP will be enabled for 30 seconds. After that time, the default IP 192.168.100.246 will be set.
3. Connect the power supply to the gateway's port marked as 1 in the figure above.



- Use a SELV rated NEC class 2 or limited power source (LPS) power supply.
- The voltage you apply must be within the admitted range. Ensure to supply enough power. Consult all requirements in the **Technical Specifications** table.



Keep communication cables away from power and ground wires.

## Configuration

Use the Intesis MAPS configuration tool to configure the gateway.

1. See instructions on how to download and install the latest version at: <https://www.hms-networks.com/software-and-tools/intesis-maps>.
2. Refer to the [Configuration Guide](#) for a detailed description of the configuration process.

## Hidden Elements: DIP Switch and Push Button

To access the gateway's DIP switch block and push button, you must remove the gateway's main front cover. Use a small flathead screwdriver or a similar tool to proceed.



Proceed with caution to avoid damaging the gateway's PCB or housing.

After setting the switches or using the push button, close the housing again, ensuring the front cover is securely fixed in its position.

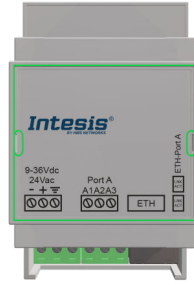

## Dimensions

- NET DIMENSIONS (HxWxD):**  
 Millimeters: 93 x 53 x 58 mm  
 Inches: 3.7 x 2.1 x 2.3"

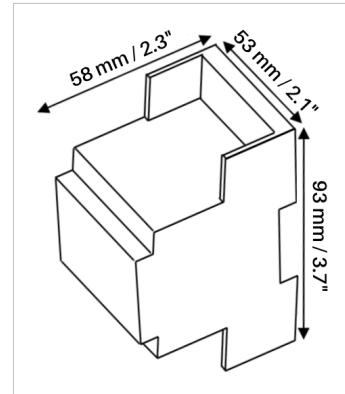

### DIP SWITCH BLOCK

The gateway has a DIP switch block dedicated to the EIA-485 port. The function of the DIP switch is to activate or deactivate the polarization (positions 1 and 2) and the termination resistor (position 3) of the port:

Binary value b0 .. b2	Switches			Description
	1	2	3	
0 0 X	OFF	OFF	X	No bus polarization (default value)
1 1 X	ON	ON	X	Bus polarization active
X X 0	X	X	OFF	120 Ω termination resistor inactive. The gateway is not at one end of the EIA-485 bus (default value)
X X 1	X	X	ON	120 Ω termination resistor active. The gateway is at one end of the EIA-485 bus

### PUSH BUTTON

Use the push button to reset the gateway to the factory settings:

- Disconnect the gateway from power.
- Press and hold the button.
- Connect the gateway to power.
  - The feedback LED (3) turns on solid red, and the button LED (2) turns on solid green.
  - The external LEDs (4) and (5) start a sequence, turning on and off alternately.
- After 10 seconds, release the button.
  - All LEDs keep performing as described in step 3. Then, they turn off, blink once, and behave as in normal operation: External LEDs (4) and (5) are off, the feedback LED (3) blinks green, and the button LED (2) is solid green.

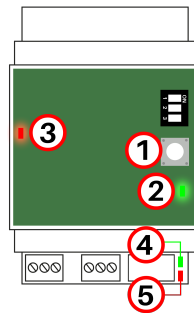

## External LED indicators

The gateway's LEDs are placed next to the Ethernet port:

- LED 1 (green)
- LED 2 (red)

Besides, the Ethernet connector has its own LEDs:

- LED 3 (orange)
- LED 4 (green)

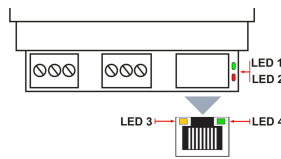

LED	Color	Description
LED 1 (Port A)	Green	<b>ON:</b> Connection with the OCPP system established <b>Blinking:</b> Receiving/transmitting OCPP packets
LED 2 (Ethernet)	Red	<b>Blinking:</b> Receiving/transmitting Modbus TCP packets
LED 3 (RJ45) Speed	Orange	<b>ON:</b> Connection to a switch, a hub, or a PC at 100 Mbps link speed. <b>OFF:</b> Connection not established, or established at 10 Mbps link speed.
LED 4 (RJ45) Link/activity	Green	<b>ON:</b> Ethernet connection established <b>Blinking:</b> Ethernet activity <b>OFF:</b> No Ethernet connection established



Leave enough clear space to wire the gateway easily and for the subsequent manipulation of elements.

## Technical Specifications

<b>Housing</b>	Plastic, type PC (UL 94 V-0). Color: Light Grey. RAL 7035 Net dimensions (HxWxD): 93 x 53 x 58 mm / 3.6 x 2.1 x 2.3"
<b>Mounting</b>	Wall DIN rail (recommended mounting) EN60715 TH35
<b>Terminal wiring</b> For power supply and low-voltage signals	Per terminal: solid wires or stranded wires (twisted or with ferrule) Wire cross-section/gauge: One core: 0.2 mm <sup>2</sup> .. 2.5 mm <sup>2</sup> (24 .. 11 AWG) Two cores: 0.2 mm <sup>2</sup> .. 1.5 mm <sup>2</sup> (24 .. 15 AWG) Three cores: Not permitted  For distances longer than 3.05 meters (10 feet), use Class 2 cables.
<b>Power</b>	1 x Green pluggable terminal block (3 poles) • 9-36 VDC / 24 VAC / 50-60 Hz / 0.140 A / 1.7 W
<b>Ethernet</b>	1 x Ethernet 10/100 Mbps RJ45
<b>Port A</b>	1 x Serial EIA-485 green pluggable terminal block (three poles) • SGND (reference ground or shield), A(-), B(+) • 1500 VDC isolation from other ports
<b>DIP switch</b>	EIA-485 port polarization and termination: Positions 1 and 2: • On: Polarization active • Off: Polarization inactive (default)  Position 3: • On: 120 Ω termination active • Off: 120 Ω termination inactive (default)
<b>Push button</b>	1 x Factory reset
<b>LED indicators</b>	2 x Onboard 2 x Ethernet Link/Speed
<b>Operational temperature</b>	Celsius: 0 .. 60°C / Fahrenheit: 32 .. 140°F
<b>Operational humidity</b>	5 to 95%, no condensation
<b>Protection</b>	IP20 (IEC60529)

## Disposal and Recycling



This product contains electronic components and must be properly disposed of according to local laws and regulations. For further information, refer to: <https://www.hms-networks.com/sustainability>

For further information on the installation, connection, and configuration of this gateway, refer to the [User manual](#).