

FACTORY AUTOMATION

**MITSUBISHI ELECTRIC
INDUSTRIAL ROBOT
MELFA CR Series**





Automating the World



Our Factory Automation business is focused on "Automating the World" to make it a better, more sustainable environment supporting manufacturing and society, celebrating diversity and contributing towards an active and fulfilling role.

Mitsubishi Electric is involved in many areas including the following:

Energy and Electric Systems

A wide range of power and electrical products from generators to large-scale displays.

Electronic Devices

A wide portfolio of cutting-edge semiconductor devices for systems and products.

Home Appliance

Dependable consumer products like air conditioners and home entertainment systems.

Information and Communication Systems

Commercial and consumer-centric equipment, products and systems.

Industrial Automation Systems

Maximizing productivity and efficiency with cutting-edge automation technology.



The Mitsubishi Electric Group is actively solving social issues, such as decarbonization and labor shortages, by providing production sites with energy-saving equipment and solutions that utilize automation systems, thereby helping towards a sustainable society.

OVERVIEW

Product lineup	5
Product features	7
Product specifications	11
Controller specifications	17
System configuration	18
Options	19

1
2
3
4
5
6



Compact & Stylish



Common & Simple



Convenient & Stress free



Increased customer satisfaction

MELFA CR Series

Scan here for the MELFA CR series concept video



Compact exterior

Installable in limited spaces

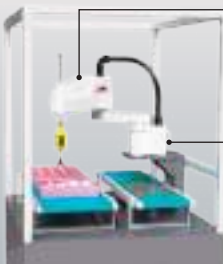

Efficient installation in limited spaces

Compact exterior allows for integration into a wide variety of systems

Stylish construction

Applications in various environments and processes



Vertical articulated models are rated IP65 as standard

Specialized basic performance

Improved continuous operation

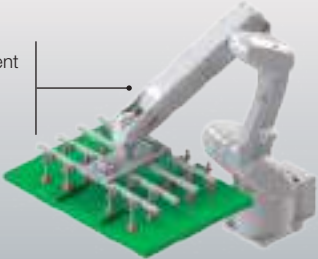

High allowable moment and inertia to reduce hand wobble

Simple design

Lightweight robot arm



Easier installation enabled by an approximate 20% weight reduction compared to our previous models

Convenient user interface

Internal wiring for reduced disconnection risk / Ample inputs and outputs



Stress-free management

Battery-less for improved maintainability (excluding the 3CRH and 6CRH)



- Eliminates the need for periodic battery replacement, freeing up the battery-replacement space.
- Eliminates restart and delay risks after holidays and equipment inspections.





Vertical articulated robot

RV-CR Series

- Slim arm and compact joints with a smooth and curved design
- Moment and inertia specifications for large hands
- Compliance for oil mist environments as standard (IP65), allowing for a variety of uses
- Battery-less for improved maintainability

RV-CR Series

Model	 RV-8CRL	 RV-12CRL
Max. payload	8 kg	12 kg
Reach	931 mm	1504 mm
Environment specifications	Oil mist (IP65)	

Model

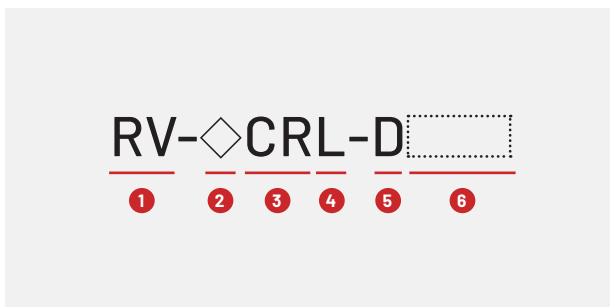

1 Robot structure
RV: Vertical articulated robot

2 Payload
8: 8 kg / 12: 12 kg

3 Series name
CR: CR Series

4 Arm length
L: Long arm

5 Controller type
D: Standalone



6 Special model number
None: 2D-TZ368 is pre-installed in the controller.
-S15: 2D-TZ378 is pre-installed in the controller.



Horizontal articulated robot
RH-CRH Series

- Reduced overall height for a compact design
- Reduced weight for improved continuous operation performance
- Multiple variations to fit various uses

RH-CRH Series

Model				
	RH-3CRH	RH-6CRH	RH-10CRH	RH-20CRH
Max. payload	3 kg	6 kg	10 kg	20 kg
Reach	400 mm	600 mm / 700 mm	600 mm / 700 mm / 800 mm	850 mm / 1000 mm
Z stroke	180 mm	200 mm	200 mm / 300 mm	420 mm
Environment specifications	Standard (IP20)			

Model

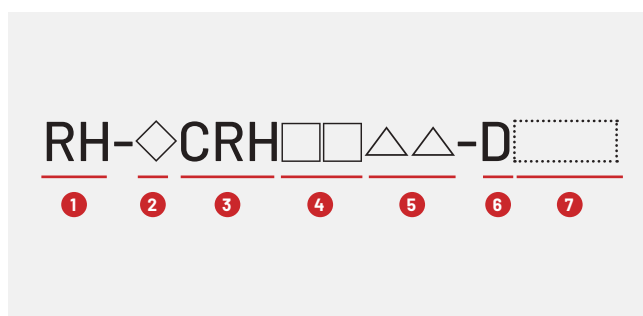

- 1 Robot structure**
RH: Horizontal articulated robot
- 2 Payload**
3: 3 kg / 6: 6 kg / 10: 10 kg / 20: 20 kg
- 3 Series name**
CRH: CRH series
- 4 Arm length**
40: 400 mm / 60: 600 mm
70: 700 mm / 80: 800 mm
85: 850 mm / 100: 1000 mm
- 5 Stroke length**
18: 180 mm / 20: 200 mm
30: 300 mm / 42: 420 mm
- 6 Controller type**
D: Standalone
- 7 Special model number**
None: 2D-TZ368 is pre-installed in the controller.
-S15: 2D-TZ378 is pre-installed in the controller.

Slim & Compact Robot Offering a High Level of Utility and Design

RV

RH

Maximum performance in minimum space

Slim & compact

A smooth, curved design complements the slim arm and compact joints. The external design is marked by minimalist, functional design.

High scalability

The MELFA RV-CR series supports a wide range of functions and options, including the tracking function (installed as standard), additional axis control (installed as standard), 2D vision sensor, force sensor, 3D vision sensor, MELFA Smart Plus, and network base card, making it useful in various situations.



RH-20CRH

RV-12CRL

Lighter unit

Compared to the MELFA FR series, the MELFA CR series is lighter thanks to a simplified drive system and optimized arm structure. The lineup has also been expanded.

MELFA RV-CR series robots are easy to integrate with automation cells and manufacturing equipment, and their slim structure makes them easy to handle.

Improved maintainability

No backup battery

The use of a HK motor eliminates the need for a battery to back up the robot's internal encoder data.

This eliminates the cost and effort of regular replacement as well as the risk of losing origin data due to battery depletion (excluding the 3CRH and 6CRH).

Belt-less coaxial drive mechanism

For vertical articulated robots, coaxial drive mechanisms transfer power to the axes without belts. (J4/J5 axes on the RV-8CRL. Excluding the J5 axis on the RV-12CRL.)

Simplification of the structure has improved transmission efficiency and reliability. Maintainability has also been improved by reducing the number of points for periodic belt inspections.

Protrusionless structure suppresses interference with surroundings

In addition to a slim, compact exterior and small robot base, the structures feature minimal protrusions on the front, back, and sides, reducing interference with surroundings during operation. Horizontal articulated robots have a slim arm and reduced overall height making them suited to integration with automation cells and manufacturing equipment.

Large grippers for various situations

RV-12CRL has a large moment / inertia and an extensive number of inputs / outputs for gripper control, which makes the installation of large and complex grippers possible.

This enables the stable transfer of large workpieces using grippers that require a large number of cylinders and pads.



Wiring/piping built into arm

Signal wiring and air piping that can be used for gripper control, etc., are built in from the base to the forearm. For the RV-8CRL series and RH-CRH series, both ends of the signal wire are equipped with universal D-sub connectors for use in various applications. RV-12CRL has two 15-pin connectors at both ends of the signal wires to handle a large number of signals. Connectors and air joints are on the side, making it easy to route the wiring.

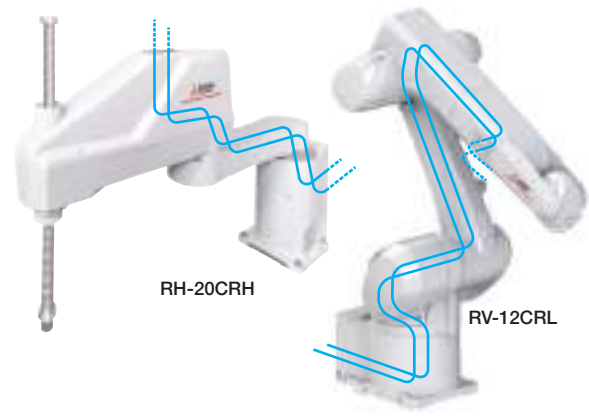

Built-in signal wiring and air piping for gripper control

Structure supporting external wiring/piping

The CR series is designed to make external wiring and piping easier. The RV-12CRL has numerous screw holes on the left side of the arm. The internal wiring and piping are routed on the right side of the robot allowing for installation without interference. For the RH-CRH series, wiring can also be routed to follow the movement of the J3 and J4 axes.



Reduced overall height for a compact design

The overall height of the RH-CRH series has been reduced by making the arm cover compact. The compact exterior enables the robot to be incorporated into a wide variety of systems.

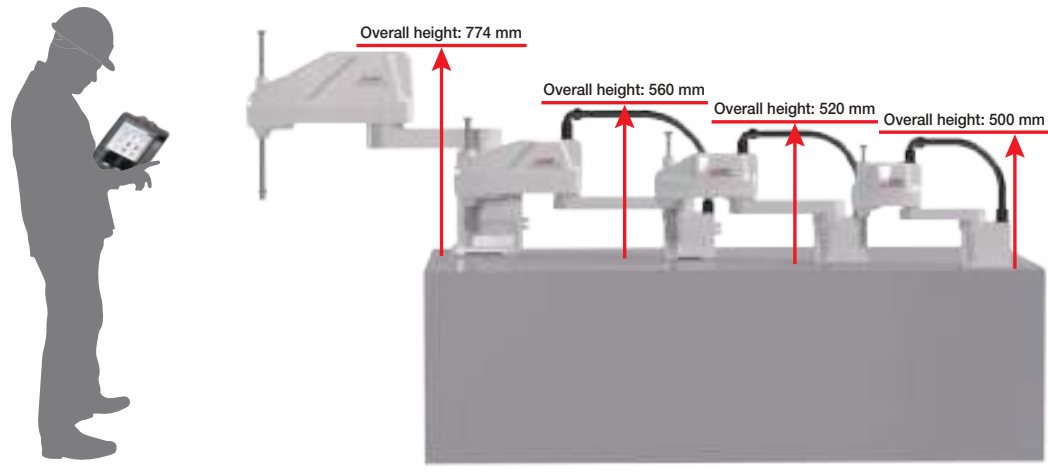

High-performance Controller Makes MELFA More Intelligent

Intelligent technology

Force sensor

- Checks pressing force and force conditions at time of insertion, improving operational quality
- Assembly of difficult-to-fit workpieces
- Teaching support via force information
- Improved force controllability via faster control cycle

Example use of intelligent technology

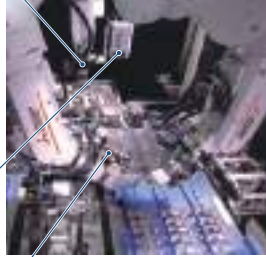

3D vision sensor

- Kitting and separation of scattered or stacked workpieces
- Simplification of installation via support functions

2D vision sensor

- Vision sensor configuration tool allows easy calibration of robot and camera
- Easy connection of robot and camera via Ethernet
- Easy control via robot program vision control command

Intelligent technology: MELFA Smart Plus*1

Advanced features such as integration functions for the various sensors and autonomous startup adjustment functions are provided for all phases of customer's operations, from design and startup through to operation and maintenance.

MELFA Smart Plus



Preventive maintenance function

Tracking the robot's operating status helps manage the condition of the robot.

Coordinated control of additional axis

Links robot and travel base for high-accuracy processing and assembly at specific speed.

Robot mechanism thermal compensation function

Compensates the thermal expansion of the robot arm to increase position accuracy.

Calibration assistance function

● Automatic calibration

Automatically adjusts the coordinates of the vision sensor to increase position accuracy.

● Workpiece coordinate calibration

Adjusts the robot and workpiece coordinates using a vision sensor to increase position accuracy.

● Relative position calibration

Automatically calibrates the positions of multiple robots using a vision sensor. Increases position accuracy in collaborative operation.

2D vision sensor enhancement function

Various vision applications are easily set up.

Force sensor enhancement function

Parameters for the optimum operation pattern are found using repeat learning in a short amount of time.

MELFA-3D Vision enhancement function

Reduced startup time thanks to automatic parameter adjustments.

*1: Not available for the RV-12CRL, RH-10CRH, and RH-20CRH. This function is supported by the RV-8CRL, RH-3CRH, and RH-6CRH with robot controller CR800-D software Ver. A5p or later.

Safety functions

Safety monitoring function

A high level of safety that complies with international standards, allows for flexibility in building equipment.

Safety I/O

Extends redundant safety I/O to 8 inputs and 4 outputs. Enables development of various safety systems.

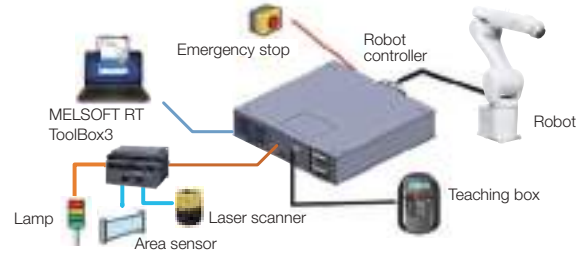

Safety logic editing

The operating conditions for the safety monitoring function can be easily defined from the setting screen.

Tracking and additional axis control

Comes standard with tracking and additional axis control

Tracking

Robot tracks workpiece on conveyor, allowing transfer, alignment, and assembly without stopping conveyor.

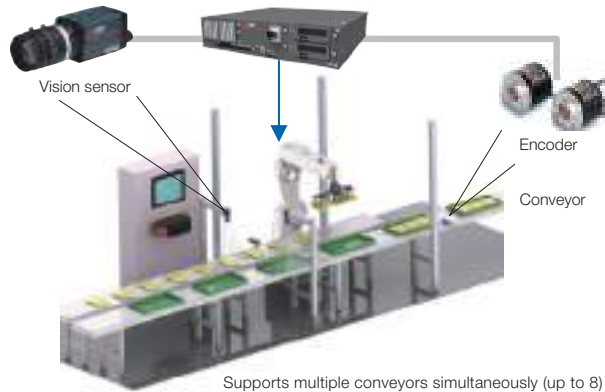

Additional axis control

Build user mechanism controlling additional axes simultaneously with robot such as robot drive axis or turntable or separate from robot such as loader or positioning device. Control up to 8 axes. Our MELSERVO (MR-J4-B) servomotor can be used with additional axes.

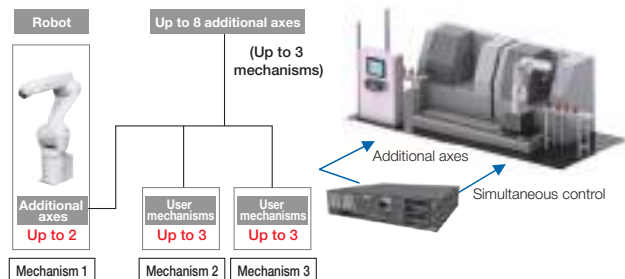

Software supporting program creation and total engineering: MELSOFT RT ToolBox3

PC software supporting everything from robot system design to installation, debugging, operation, and maintenance

- Program editing and debugging
- Simulation function
- 3D viewer
- Monitoring function
- Melfa RXM.ocx communication middleware



Visual programming

The visual programming function creates programs simply by connecting blocks corresponding to each command.

Visual programming enables intuitive operation, which makes it easy to start up robots even without knowledge of robotics.

Supporting major networks

Supports various networks for system expansion

Compatible with an optional network base card that supports four major networks, enabling system configuration using devices from various manufacturers and communication with higher-level devices.

Network	Base card model
CC-Link IE Field	2F-DQ535
EtherCAT	2F-DQ535-EC
EtherNet/IP	2D-TZ535
PROFINET	2D-TZ535-PN

Low-profile controller

Space-saving design

The CR800 controller is slim with a height of 99.5 mm and can be used in both vertical and horizontal positions. The controller can be placed in a variety of positions to fit into the available space of a device, contributing to space-saving.

Abundant inputs and outputs

Parallel I/O interface included as standard

For the CR series, the parallel I/O interface card is installed in the controller as standard. 32 inputs and 32 outputs can be externally inputted/outputted, which can be used for gripper control and peripheral equipment control.

Gripper cable options

For RV-12CRL, gripper cable options are available. This provides easier signal management of the gripper and controller, and reduces installation work-hours.

GOT integration

Directly linked with GOT

Enhanced efficiency of monitoring and maintenance operations onsite using a single GOT (display device) as the Human Machine Interface (HMI).

Example of GOT display



Enables the robot to be controlled from the GOT even without a teaching box.

Current robot position data, error information, etc. can be displayed easily on the GOT.

Internal robot information

- Error, variable, and program information
- Robot status (Current speed, current position, etc.)
- Maintenance information (Remaining battery capacity, grease life, etc.)
- Servo data (Load factor, current values, etc.)

Sample image files can be downloaded from the Mitsubishi Electric FA website.

- Useful sample image files that can immediately be used in actual systems.
- Sample sequence programs (function blocks) are provided for using the sample image files.

Note) The sample image files are for the GT27 (640 × 480 or better). To use the files, GT Designer3 version 1.178L or later is required.

Product specifications

MELFA RV-8CRL

Vertical 8 kg Type

RV-8CRL



Specifications

Item	Unit	RV-8CRL	
IP rating		IP65*1	
Environment		Oil mist specification	
Installation posture		On floor, hanging, (against wall*2)	
Connected controller		CR800-CVD	
Structure		Vertical articulated robot	
Degree of freedom		6	
Load	Rating	kg	7
	Maximum	kg	8*3
Max. reach (P point)	mm	931	
Arm length	mm	450+470	
Operating range	J1	Degree	±170
	J2	Degree	±110
	J3	Degree	+0 to +165
	J4	Degree	±200
	J5	Degree	±120
	J6	Degree	±360
Maximum speed*4	J1	Degree/s	288
	J2	Degree/s	321
	J3	Degree/s	360
	J4	Degree/s	337
	J5	Degree/s	450
	J6	Degree/s	720
Pose repeatability	mm	±0.02	
Ambient temperature	°C	0 to 40	
Allowable moment load	J4	Nm	16.2
	J5	Nm	16.2
	J6	Nm	6.86
Allowable inertia	J4	kgm ²	0.45
	J5	kgm ²	0.45
	J6	kgm ²	0.10
Mass	kg	41	
Tool wiring		D-sub 15 pins	
Tool pneumatic pipes		Φ6 × 2	

External dimensions/operating range

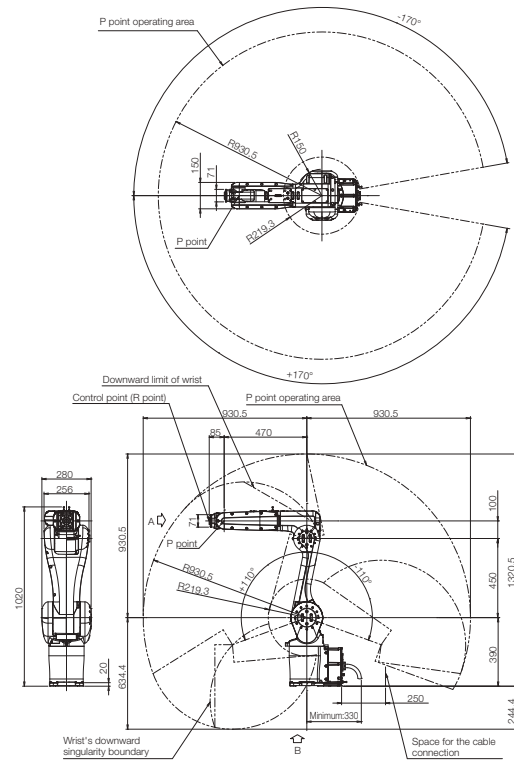

Mechanical interface

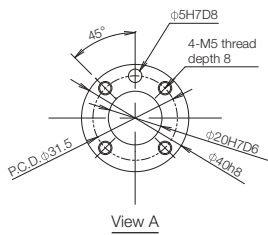

Internal wiring/piping

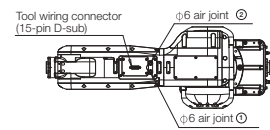

Wiring/piping

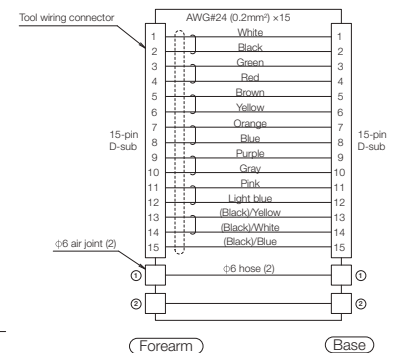

Installation dimensions

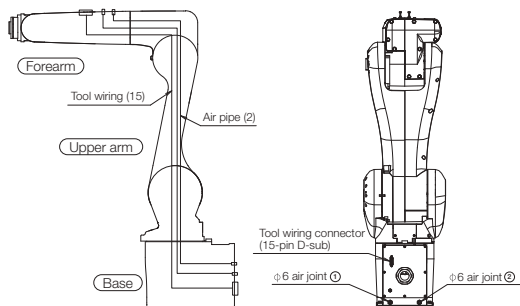
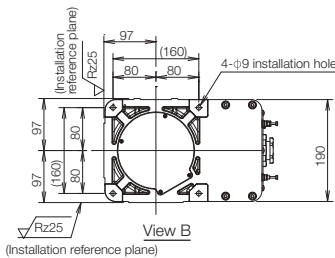

*1: Electrical devices and high-speed rotating parts susceptible to the effects of dust and water inside the arm are under the protection of IP65. Refer to the standard specifications manual for details.

*2: The wall mounting specifications are special specifications that restrict the operating range of the J1 axis.

*3: "Maximum load capacity" is the maximum weight that can be loaded under the limitation of a mechanical interface having a downward attitude (within ±10° of the vertical position).

*4: The maximum speed indicates the peak value, and the speed of each axis varies depending on factors such as the posture, load, and the amount of movement.

MELFA RV-12CRL

Vertical 12 kg Type



RV-12CRL

Specifications

Item	Unit	RV-12CRL	
IP rating		IP65*1	
Environment		Oil mist specification	
Installation posture		On floor, hanging	
Connected controller		CR800-12CVD	
Structure		Vertical articulated robot	
Degree of freedom		6	
Load	Rating	kg	12
	Maximum	kg	12
Max. reach (P point)	mm	1504	
Arm length	mm	600+760	
Operating range	J1	Degree	±170
	J2	Degree	-90 to +150
	J3	Degree	+0 to +170
	J4	Degree	±190
	J5	Degree	±120
	J6	Degree	±360
Maximum speed*2	J1	Degree/s	270
	J2	Degree/s	253
	J3	Degree/s	290
	J4	Degree/s	487
	J5	Degree/s	480
	J6	Degree/s	780
Pose repeatability	mm	±0.04	
Ambient temperature	°C	0 to 40	
Allowable moment load	J4	Nm	26.5
	J5	Nm	26.5
	J6	Nm	11
Allowable inertia	J4	kgm ²	0.9
	J5	kgm ²	0.9
	J6	kgm ²	0.3
Mass	kg	110	
Tool wiring		2×15 pins	
Tool pneumatic pipes		Φ6 × 2, Φ8 × 1	

External dimensions/operating range

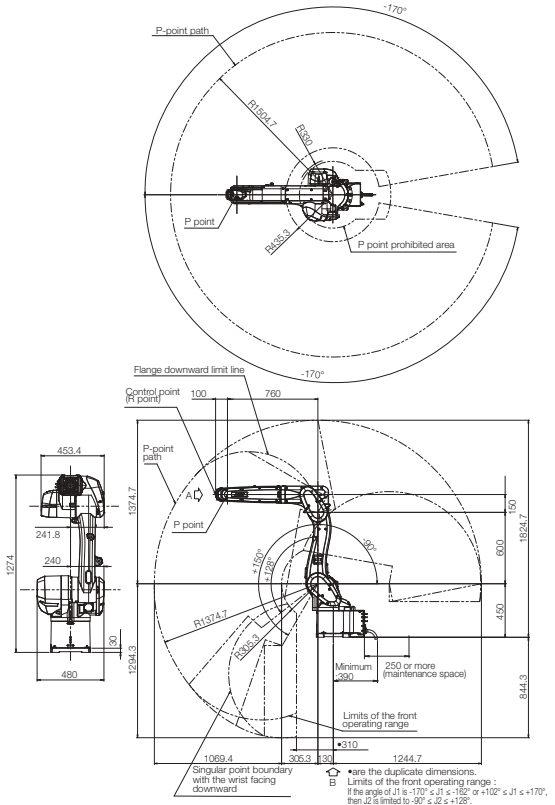

Mechanical interface

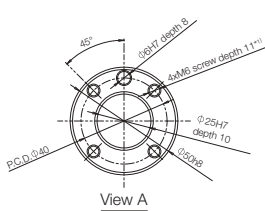

Internal wiring/piping

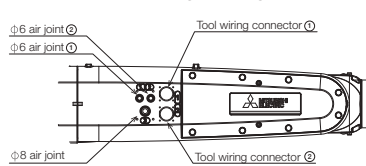

Installation dimensions

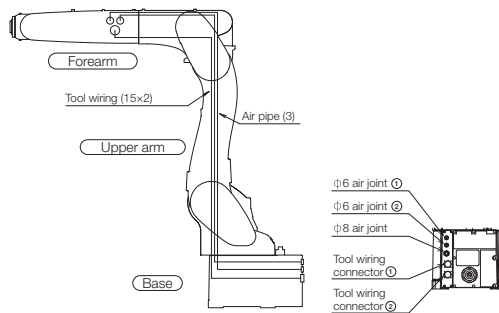
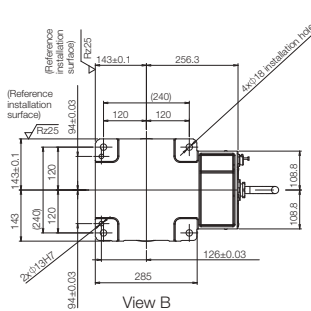

Wiring/piping

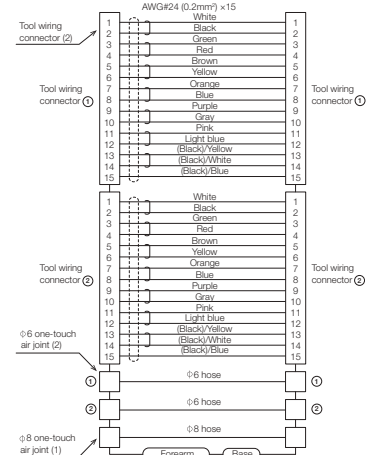

*1: Electrical devices and high-speed rotating parts susceptible to the effects of dust and water inside the arm are under the protection of IP65. Refer to the standard specifications manual for details.

*2: The maximum speed indicates the peak value, and the speed of each axis varies depending on factors such as the posture, load, and the amount of movement.

MELFA RH-3CRH

Horizontal 3 kg Type

Specifications

Item	Unit	RH-3CRH4018
IP rating		IP20
Environment		Standard
Installation posture		On floor
Connected controller		CR800-CHD
Structure		Horizontal articulated robot
Degree of freedom		4
Load	Rating	kg
	Maximum	kg
Max. reach (Arm No. 1 + Arm No. 2)	mm	400
Arm length	Arm No. 1	mm
	Arm No. 2	mm
Operating range	J1	Degree
	J2	Degree
	J3 (Z)	mm
	J4 (θ)	Degree
Maximum speed*1	J1	Degree/s
	J2	Degree/s
	J3	mm/s
	J4	Degree/s
Pose repeatability	X-Y composite	mm
	J3 (Z)	mm
	J4 (θ)	Degree
Ambient temperature	°C	0 to 40
Allowable inertia	Rating	kgm ²
	Maximum	kgm ²
Mass	kg	14
Tool wiring		15 points, D-SUB
Tool pneumatic pipes		Φ6 × 2, Φ4 × 1
Brake		J1, J2, J4 axes (without brake) J3 axis (with brake)



RH-3CRH

Operating range

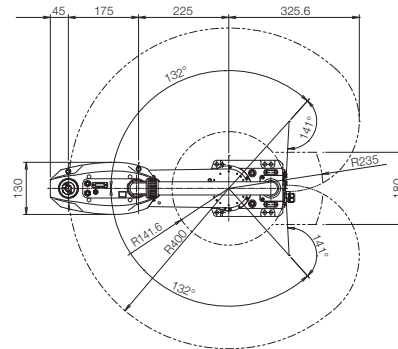

External dimensions

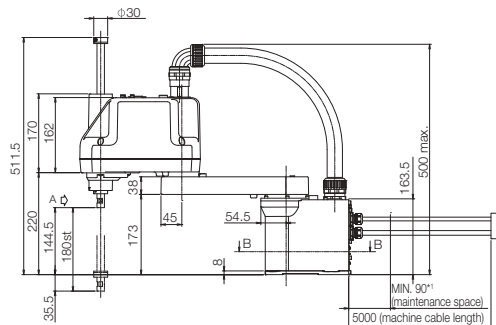
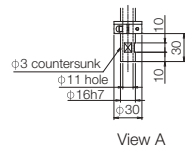
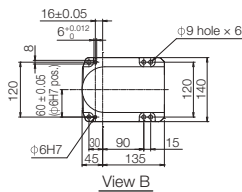

*1: This is the space required for battery replacement, and indicates the dimensions including the minimum bending radius of the machine cable.

*1: The values are taken when the robot is in MvTune2 (high-speed operation mode). Additionally, the values are taken under load conditions where no effect comes from automatic speed compensation due to the load mass.

MELFA RH-6CRH

Horizontal 6 kg Type

Specifications

Item	Unit	RH-6CRH6020	RH-6CRH7020
IP rating		IP20	
Environment		Standard	
Installation posture		On floor	
Connected controller		CR800-CHD	
Structure		Horizontal articulated robot	
Degree of freedom		4	
Load	Rating	kg	
	Maximum	kg	
Max. reach (Arm No. 1 + Arm No. 2)	mm	600	700
Arm length	Arm No. 1	mm	325
	Arm No. 2	mm	275
Operating range	J1	Degree	264 (±132)
	J2	Degree	300 (±150)
	J3 (Z)	mm	200
	J4 (θ)	Degree	720 (±360)
Maximum speed*1	J1	Degree/s	420
	J2	Degree/s	360
	J3	mm/s	720
	J4	mm/s	1100
Pose repeatability	J1+J2	mm/s	2500
	X-Y composite	mm	7800
Pose repeatability	J3 (Z)	mm	±0.02
	J4 (θ)	mm	±0.01
Ambient temperature	°C	0 to 40	
Allowable inertia	Rating	kgm ²	
	Maximum	kgm ²	
Mass	kg	17	18
Tool wiring		15 points, D-SUB	
Tool pneumatic pipes		Φ6 × 2, Φ4 × 1	
Brake		J1, J2 axes (without brake) J3, J4 axes (with brake)	



RH-6CRH

Operating range

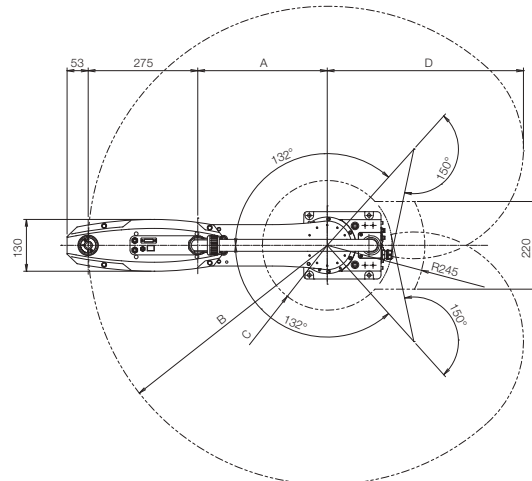

External dimensions

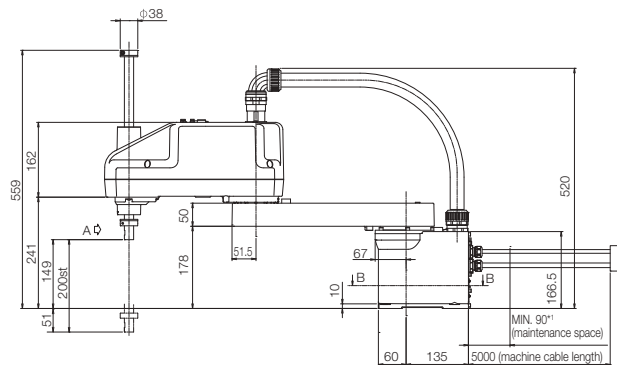
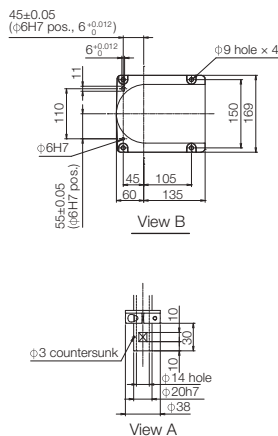

*1: This is the space required for battery replacement, and indicates the dimensions including the minimum bending radius of the machine cable.

Model	A	B	C	D
RH-6CRH6020	325	R600	R162.6	492.5
RH-6CRH7020	425	R700	R232	559.4

*1: The values are taken when the robot is in MvTune2 (high-speed operation mode). Additionally, the values are taken under load conditions where no effect comes from automatic speed compensation due to the load mass.

MELFA RH-10CRH

Horizontal 10 kg Type

Specifications

Item	Unit	RH-10CRH60XX	RH-10CRH70XX	RH-10CRH80XX	
IP rating		IP20			
Environment		Standard			
Installation posture		On floor			
Connected controller		CR800-C2HD			
Structure		Horizontal articulated robot			
Degree of freedom		4			
Load	Rating	kg			
	Maximum	kg			
Max. reach (Arm No. 1 + Arm No. 2)	mm	600	700	800	
Arm length	Arm No. 1	mm	225	325	
	Arm No. 2	mm	375		
Operating range	J1	Degree	264 (±132)		
	J2	Degree	300 (±150)		
	J3 (Z)	mm	XX=20:200 / XX=30:300		
	J4 (θ)	Degree	720 (±360)		
Maximum speed*1	J1	Degree/s	420		
	J2	Degree/s	720		
	J3	mm/s	1100		
	J4	Degree/s	2700		
Pose repeatability	J1+J2	mm/s	9100	9840	10570
	X-Y composite	mm	±0.02		
	J3 (Z)	mm	±0.01		
	J4 (θ)	Degree	±0.01		
Ambient temperature	°C	0 to 40			
Allowable inertia	Rating	kgm ²	0.02		
	Maximum	kgm ²	0.3		
Mass*2	kg	20	21		
Tool wiring		15 points, D-SUB			
Tool pneumatic pipes		Φ6 × 2, Φ4 × 1			
Brake		J1, J2 axes (without brake) J3, J4 axes (with brake)			



RH-10CRH

Operating range

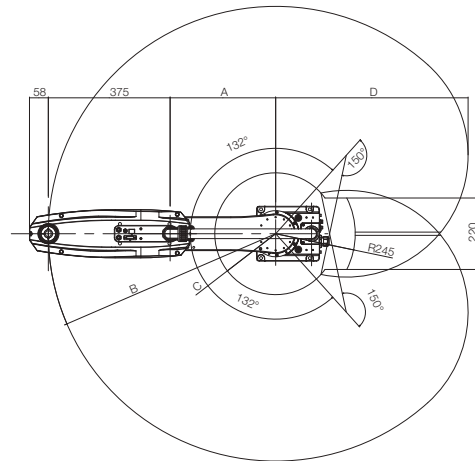

External dimensions

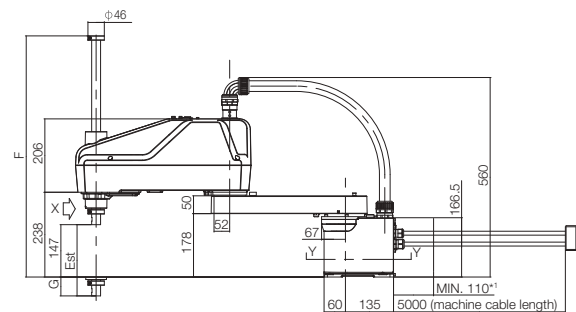
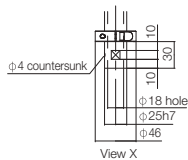
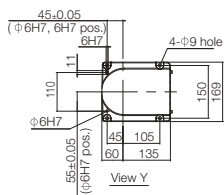

*1: Dimensions including the minimum bending radius for the machine cable.

Model	A	B	C	D	E (J3 stroke)	F	G
RH-10CRH60XX	225	R600	R212.4	525.6	200/300	577/677	53/153
RH-10CRH70XX	325	R700	R187.5	592.5	200/300	577/677	53/153
RH-10CRH80XX	425	R800	R212.6	659.4	200/300	577/677	53/153

*1: The values are taken when the robot is in MvTune2 (high-speed operation mode). Additionally, the values are taken under load conditions where no effect comes from automatic speed compensation due to the load mass.

*2: The weight of the machine cable is not included.

MELFA RH-20CRH

Horizontal 20 kg Type

Specifications

Item	Unit	RH-20CRH8542	RH-20CRH10042	
IP rating		IP20		
Environment		Standard		
Installation posture		On floor		
Connected controller		CR800-C2HD		
Structure		Horizontal articulated robot		
Degree of freedom		4		
Load	Rating	kg		
	Maximum	kg		
Max. reach (Arm No. 1 + Arm No. 2)	mm	850	1000	
Arm length	Arm No. 1	mm	375	
	Arm No. 2	mm	475	
Operating range	J1	Degree	340 (±170)	
	J2	Degree	290 (±145)	306 (±153)
	J3 (Z)	mm	420	
	J4 (θ)	Degree	720 (±360)	
Maximum speed*1	J1	Degree/s	375	
	J2	Degree/s	600	
	J3	mm/s	2300	
	J4	Degree/s	1600	
Pose repeatability	J1+J2	mm/s	10530	11510
	X-Y composite	mm	±0.025	
Ambient temperature	J3 (Z)	mm	±0.01	
	J4 (θ)	Degree	±0.01	
Allowable inertia	Rating	kgm ²	0.05	
Mass*2	Maximum	kgm ²	1.0	
		kg	54	57
Tool wiring		15 points, D-SUB, 9 points, D-SUB		
Tool pneumatic pipes		Φ8 × 2, Φ6 × 2		
Brake		J1, J2 axes (without brake) J3, J4 axes (with brake)		



RH-20CRH

Operating range

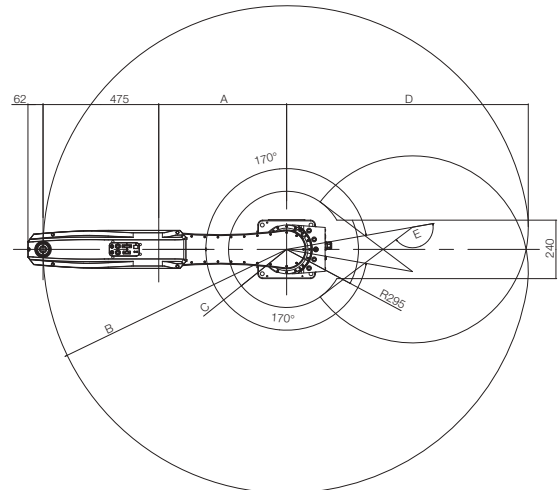

External dimensions

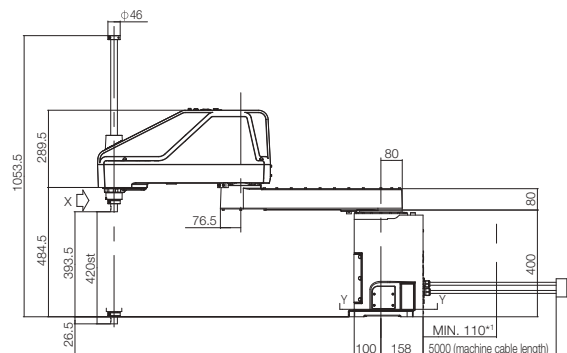
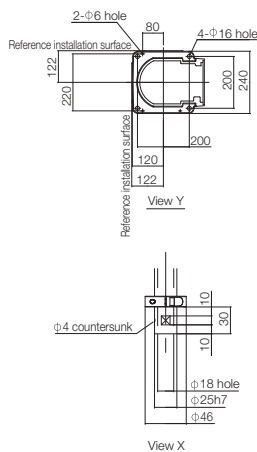

*1: Dimensions including the minimum bending radius for the machine cable.

Model	A	B	C	D	E
RH-20CRH8542	375	R850	R221	844.3	145°
RH-20CRH10042	525	R1000	R238.5	992	153°

*1: The values are taken when the robot is in MvTune2 (high-speed operation mode). Additionally, the values are taken under load conditions where no effect comes from automatic speed compensation due to the load mass.

*2: The weight of the machine cable is not included.

Controller specifications

MELFA Controller CR800

Stand-alone robot controller
Robot controller can be used for centralized control.



CR800-CVD
CR800-12CVD
CR800-CHD
CR800-C2HD

External dimensions

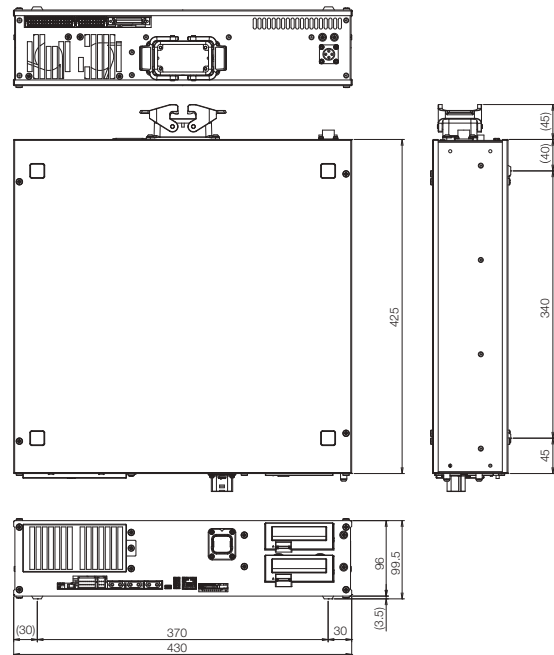

Specifications

Item	Unit	CR800	
Number of axes controlled		Vertical articulated robot: 6 axes at a time (Up to 8 axes can be added.) Horizontal articulated robot 4 axes at a time (Up to 8 axes can be added.)	
Robot language		MELFA-BASIC V, VI	
Memory capacity	Number of teaching points	39000	
	Number of steps	78000	
	Number of programs	512	
External input/output	General-purpose I/O	32 inputs/32 outputs 2D-TZ368 (sink type) is attached at the time of shipment. The 2D-TZ378 (source type) is installed from the factory in the S15 with special specifications	
	Dedicated I/O	Assigned to general-purpose I/O	
	Emergency stop input	1 (Redundant)	
	Door switch input	1 (Redundant)	
	Mode selector switch input *1	1 (Redundant)	
	Emergency stop output	1 (Redundant)	
	Mode output	1 (Redundant)	
	Robot error output	1 (Redundant)	
	Synchronization of additional axes	1 (Redundant)	
Encoder input	channel	2	
Interface	Additional axis, force sensor interface	channel	1 (SSCNET III/H)
	Remote I/O	channel	1 (Compatible with Ver. 1.0/2.0)
	USB	port	1 (Ver. 2.0 High Speed device functions only. USB mini-B)
	Ethernet	port	1 (For user: 1000BASE-T/100BASE-TX/10BASE-T) 1 (For T/B: 100BASE-TX/10BASE-T)
	Extension slot	slot	2 *2
	SD memory card slot	slot	1 (For extended memory)
	RS-422	port	1 (Dedicated T/B)
Ambient temperature	°C	0 to 40	
Ambient humidity	%RH	45 to 85	
Power supply	Input voltage range *3	V	RV-8CRL, RH-10CRH, RH-20CRH: Single-phase 200 to 230 V AC RV-12CRL: Single-phase 230 V AC / Three-phase 200 to 230 V AC
	Power capacity *4	kVA	RV-8CRL: 2.0 RV-12CRL: 3.0 RH-3CRH, RH-6CRH: 0.5 RH-10CRH, RH-20CRH: 1.5
External dimensions	mm	430 (W)×425 (D)×99.5 (H)	
Mass	kg	Approx. 12.5	
Structure		Self-contained/open structure (can be placed vertically or horizontally) [IP20]	
Grounding *5	Ω	100 or less (Class D grounding)	

*1: Mode selector switch is to be provided by the customer.

*2: For installing optional interface. The 2D-TZ368 is pre-installed in slot 1 of 2. The 2D-TZ378 is pre-installed in the S15 which has special specifications. Two connectors for the 2D-TZ368 and 2D-TZ378 are included. The cable is to be supplied and connected by the customer.

*3: Power supply voltage variability is within 10%.

*4: The power capacity is the recommended value. The power capacity does not include the rush current when the power is turned ON. The power capacity is a guideline.

*5: Grounding work is to be performed by the customer.

System configuration

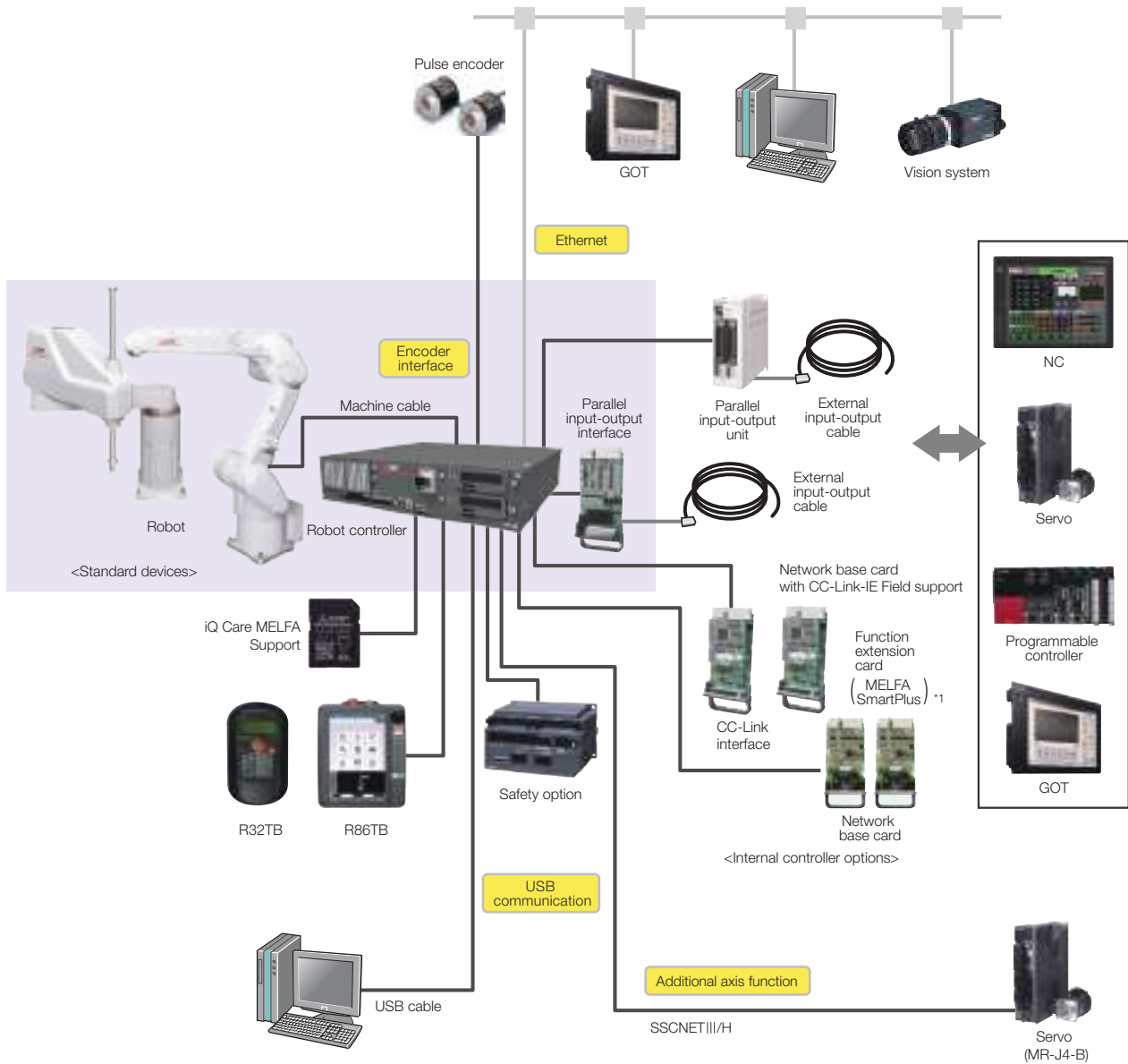

<Software options>



MELSOFT RT ToolBox3
MELSOFT RT ToolBox3 mini
MELSOFT RT ToolBox3 Pro

<Functional option>



Force sensor set



MELFA-3D Vision 3.0



Camera head is to be provided by the customer.
Manufacturer: ENSENSO GmbH
(Distributor: IDS Imaging Development Systems GmbH)

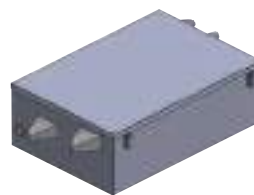

Controller protection box

*1: RV-8CRL, RH-3CRH and RH-6CRH are supported with robot controller CR800-D with software Ver. A5p or later.

Options

Mechanical options

O: Supported, Δ: Partially supported, -: Not supported

Name	Model	RV-8CRL	RV-12CRL	RH-3/6CRH	RH-10/20CRH	Specifications
Hand input-output cable	1F-HC1000S-43	-	O	-	-	Robot side: Connector, Hand side: Wire
Machine cable (replaceable type)	1F-□□CBL-42	-	-	O	-	Fixed type: 3 m, 10 m, 15 m, 20 m. "□□" indicates the cable length (3 m, 10 m, 15 m, or 20 m)
	1F-□□CBL-43	O	O	-	-	Fixed type: 10 m, 15 m, 20 m. "□□" indicates the cable length (10 m, 15 m, or 20 m)
Machine cable (replacement) (Bending)	1F-□□CBL-42	-	-	O	-	Flexible type: 10 m, 15 m, 20 m. "□□" indicates the cable length (10 m, 15 m, or 20 m)
	1F-□□CBL-43	O	O	-	-	Flexible type: 10 m, 15 m, 20 m. "□□" indicates the cable length (10 m, 15 m, or 20 m)
	1F-□□CBL-45	-	-	-	O	Flexible type: 10 m, 15 m, 20 m. "□□" indicates the cable length (10 m, 15 m, or 20 m)
J1 axis operating range change	1F-DH-42J1	-	O	-	-	The customer is responsible for purchasing the stopper and setting the limits to 150 degrees on the + and - sides.

Controller options

O: Supported, Δ: Partially supported, -: Not supported

Name	Model	RV-8CRL	RV-12CRL	RH-3/6CRH	RH-10/20CRH	Specifications
Simple teaching box	R32TB	O	O	O	O	Cable length: 7 m
	R32TB-15	O	O	O	O	Cable length: 15 m
High performance teaching box	R86TB	O	O	O	O	Cable length: 7 m. For a length longer than 7 m, use a teaching box extension cable.
Parallel input-output unit	(Sink type) 2A-RZ361	O	O	O	O	Input: 32 points/Output: 32 points Insulated output signal (Output signal: 0.1 A/24 V/point) Insulated input signal (Input signal: 7 mA/24 V/point)
	(Source type) 2A-RZ371	O	O	O	O	Insulated output signal (Output signal: 0.1 A/24 V/point) Insulated input signal (Input signal: 7 mA/24 V/point)
External input-output cable (5 m, 15 m)	2A-CBL□□	O	O	O	O	CBL05: 5 m / CBL15: 15 m Used to connect the external I/O unit to peripheral equipment.
Parallel input-output interface	(Sink type) 2D-TZ368	O	O	O	O	Input: 32 points/Output: 32 points Insulated output signal (Output signal: 0.1 A/24 V/point) Insulated input signal (Input signal: 9 mA/24 V/point)
	(Source type) 2D-TZ378	O	O	O	O	Insulated output signal (Output signal: 0.1 A/24 V/point) Insulated input signal (Input signal: 9 mA/24 V/point)
External input-output cable (5 m, 15 m)	2D-CBL□□	O	O	O	O	CBL05: 5 m CBL15: 15 m Used to connect the external I/O interface to the peripheral.
Controller protection box	CR800-MB	O	O	O	O	IP54
MELSOFT RT ToolBox3	3F-14C-WINJ	O	O	O	O	With simulation function
MELSOFT RT ToolBox3 mini	3F-15C-WINJ	O	O	O	O	Simple
MELSOFT RT ToolBox3 Pro	3F-16D-WINJ	O	O	O	O	Professional
SD memory card	2F-2GBSD	O	O	O	O	Capacity: 2 GB
CC-Link interface	2D-TZ576	O	O	O	O	Supports only intelligent device stations and local stations.
Network base card (Ethernet/IP interface)	2D-TZ535	O	O	O	O	Communication interface for HMS Anybus-CompactCom module. HMS EtherNet/IP module (AB6314-B-218) is to be provided by the customer.
Network base card (PROFINET interface)	2D-TZ535-PN	O	O	O	O	Communication interface for HMS Anybus-CompactCom module. HMS PROFINET module (AB6489-B) is to be provided by the customer.
Network base card (CC-Link IE Field interface)	2F-DQ535	O	O	O	O	Communication interface for HMS Anybus-CompactCom module. HMS CC-Link IE Field module (AB6709-B-116) is to be provided by the customer.
Network base card (EtherCAT interface)	2F-DQ535-EC	O	O	O	O	Communication interface for HMS Anybus-CompactCom module. HMS EtherCAT module (AB6707-D-224) is to be provided by the customer.

Functional options

O: Supported, Δ: Partially supported, -: Not supported

Name	Model	RV-8CRL	RV-12CRL	RH-3/6CRH	RH-10/20CRH	Specifications
Force sensor set	4F-FS002H-W200	O	O	-	-	Set of equipment required for force control function, including force sensor, interface unit, and support software
	4F-FS002H-W1000	O	O	-	-	
MELFA-3D Vision 3.0	3F-53U-WINM	O	O	O	O	Software that connects a compact 3D vision sensor for robots to measure and recognize parts.
Safety option	4F-SF002-01	O	O	O	O	Supports safety I/O.
	4F-SF003-05	O	O	O	O	

Expanded software functions

O: Supported, Δ: Partially supported, -: Not supported

Name	Model	RV-8CRL	RV-12CRL	RH-3/6CRH	RH-10/20CRH	Specifications
MELFA Smart Plus card pack *1	2F-DQ510	O	-	O	-	Enables all Type A functions
	2F-DQ520	O	-	O	-	Enables all Type A and B functions
MELFA Smart Plus card *1	2F-DQ511	O	-	O	-	Enables one Type A function of your choice
	2F-DQ521	O	-	O	-	Enables one Type B function of your choice
iQ Care MELFA Support *2	RA-1W00M**	O	Δ *3	O	Δ *3	One-year additional warranty package
	RA-2W00M**	O	Δ *3	O	Δ *3	Two-year additional warranty package
	RA-0W11M**	O	Δ *3	O	Δ *3	Simple inspection service package
	RA-0W21M**	O	Δ *3	O	Δ *3	Precise inspection service package
	RA-1W11M**	O	Δ *3	O	Δ *3	One-year additional warranty & simple inspection service package
RA-1W21M**	O	Δ *3	O	Δ *3	One-year additional warranty & precise inspection service package	

Classification	Name	Model	Specifications
Intelligent functions	Calibration assistance function	A	Supports calibration of position with other equipment using 2D vision sensor
	Automatic calibration		Automatically corrects vision sensor coordinates to improve positional accuracy
	Work coordinate calibration		Corrects robot and workpiece coordinates using vision sensor to improve positional accuracy
	Relative position calibration		Corrects position between multiple robots using vision sensor. Improves positional accuracy of coordinated actions
	2D vision sensor enhancement function	A	A vision application can be set up easily by following the instructions on the setting screens even when robot programs that require specialist knowledge have not been created.
Robot mechanism thermal compensation function	A	Compensates for thermal expansion of robot arm to improve positional accuracy	
Coordinate control of additional axes	A	Performs high-accuracy coordinated (interpolation) work with additional axes (direct coaxial)	
Preventive maintenance function (Maintenance simulation, wear calculation function)	A	Manages robot condition by tracking operational status	
AI functions	MELFA-3D Vision enhancement function	B	Utilizes AI technology to automate 3D vision sensor adjustments and improve measurement and recognition performance
	Predictive maintenance function (Fault detection function)	B	Detects falling drive parts before abnormalities in robot behavior become apparent. *By enabling this function, the predictive maintenance function (maintenance simulation and wear calculation function) can also be used.
	Enhancement function for force sense control	B	Utilizes AI technology for repeated learning in short time periods and to calculate optimal insertion patterns

*1: This function is supported by the RV-8CRL, RH-3CRH, and RH-6CRH with robot controller CR800-D software Ver. A5p or later.

*2: ** refers to the code for the region the product was purchased in (two alphabetic characters).

*3: The predictive maintenance function of the monitoring service is not supported.



Lined writing area consisting of 25 horizontal lines.

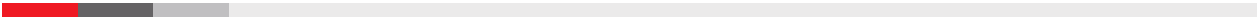

Lined writing area consisting of 25 horizontal lines.

Creating Solutions Together.



Low-voltage Power Distribution Products



Transformers, Med-voltage Distribution Products



Power Monitoring and Energy Saving Products



Power (UPS) and Environmental Products



Compact and Modular Controllers



Servos, Motors and Inverters



Visualization: HMIs



Edge Computing Products



Numerical Control (NC)



Collaborative and Industrial Robots



Processing machines: EDM, Lasers



SCADA, analytics and simulation software

Mitsubishi Electric's product lineup, from various controllers and drives to energy-saving devices and processing machines, all help you to automate your world. They are underpinned by software, innovative data monitoring, and modelling systems supported by advanced industrial networking and Edgecross IT/OT connectivity. Together with a worldwide partner ecosystem, Mitsubishi Electric factory automation (FA) has everything to make IoT and Digital Manufacturing a reality.

With a complete portfolio and comprehensive capabilities that combine synergies with diverse business units, Mitsubishi Electric provides a one-stop approach to how companies can tackle the shift to clean energy and energy conservation, carbon neutrality and sustainability, which are now a universal requirement of factories, buildings, and social infrastructure.

We at Mitsubishi Electric FA are your solution partners waiting to work with you as you take a step toward the realization of sustainable manufacturing and society through the application of automation. Let's automate the world together!

Global Partner. Local Friend

USA Mitsubishi Electric Automation, Inc. 500 Corporate Woods Parkway, Vernon Hills, IL 60061, U.S.A. TEL: +1-847-478-2100	Brazil Mitsubishi Electric do Brazil Comercio e Servicos Ltda. Avenida Adelino Cardana, 293, 21.o andar, Bethaville, Barueri SP, Brazil 06401-147 TEL: +55 (11) 4689-3003	Mexico Mitsubishi Electric Automation, Inc. Mexico Branch Boulevard Miguel de Cervantes Saavedra 301, Torre Norte Piso 5 Col. Ampliacion Granada, Miguel Hidalgo, Ciudad de Mexico, C.P.11520, Mexico TEL: +52(55)3067-7500
Australia Mitsubishi Electric Australia Pty. Ltd 348 Victoria Road, Rydalmere, NSW, 2116 Australia TEL: +61-2-9684-7777	China Mitsubishi Electric Automation (China) Ltd. No.1386 Hongqiao Road, Mitsubishi Electric Automation Center 3FShanghai, China TEL: +86-21-2322-3030	Taiwan Mitsubishi Electric Taiwan Co., Ltd. 10F, No.88 Sec. 6, Chung-Shan N.Rd,Taipei, Taiwan, TEL: +886-02-2833-5430
Korea Mitsubishi Electric Automation Korea Co.,Ltd 7F-9F, Gangseo Hangang Xi-tower A, 401, Yangcheon-ro, Gangseo-Gu, Seoul 157-801, Korea TEL: +82-2-3664-8333	Singapore Mitsubishi Electric Asia Pte. Ltd 307 Alexandra Road, Mitsubishi Electric Building, Singapore 159943 TEL: +65-6473-2486	Malaysia MITSUBISHI ELECTRIC SALES MALAYSIA SDN. BHD. Lot 11, Jalan 51A/219, Seksyen 51A, 46100 Petaling Jaya, Selangor Darul Ehsan, Malaysia +60-3-7626-5000
Indonesia PT. Mitsubishi Electric Indonesia Gedung Jaya 8th Floor, JL. MH. Thamrin No.12, Jakarta Pusat 10340, Indonesia TEL: +62-21-3192-6461	Vietnam Mitsubishi Electric Vietnam Company Limited 11th & 12th Floor, Viettel Tower B, 285 Cach Mang Thang Tam Street, Ward 12, District 10, Ho Chi Minh City, Vietnam. TEL: +84-28-3910-5945	Thailand Mitsubishi Electric Factory Automation (Thailand) Co., Ltd. 101, True Digital Park Office, 5th Floor, Sukhumvit Road, Bang Chak, Prakanong, Bangkok, Thailand TEL: +66-2092-8600
Philippines MELCO Factory Automation Philippines Inc. 128, Lopez-Rizal St. Brgy. Highway Hills, Mandaluyong City, MM, Philippines TEL: +63(0)2-8256-8042	India Mitsubishi Electric India Pvt. Ltd. ICC-Devi Gaurav Technology Park, Unit no.402, Fourth Floor, Survey no. 191-192 (P) ,Opp. Vallabh Nagar Bus Depot, Pune - 411018, Maharashtra, India TEL:+91-(20)-46242100	Germany Mitsubishi Electric Europe B.V. German Branch Mitsubishi-Electric-Platz 1, 40882 Ratingen, Germany TEL: +49-2102-486-0
UK Mitsubishi Electric Europe B.V. UK Branch Travellers Lane, Hatfield, Hertfordshire, AL10 8XB, U.K TEL: +44 (0) 1707/28-87-80	Italy Mitsubishi Electric Europe B.V. Italian Branch Energy Park Via Energy Park 14, 20871, Vimercate (MB) TEL: +39-039-60531	Spain Mitsubishi Electric Europe, B.V. Spanish Branch Carretera de Rubi, 76-80-AC. 4720, E-08190 Sant Cugat del Valles (Barcelona), Spain TEL: +34-935-65-3131
France Mitsubishi Electric Europe B.V. French Branch 2, Rue de l'Union-92565 Rueil-Malmaison Cedex TEL: +33 (0) 1-55-68-57-01,	Czech Republic Mitsubishi Electric Europe B.V. Czech Branch, Prague Office Pekarska 621/7, 155 00 Praha 5, Czech Republic TEL: +420-734-402-587	Poland Mitsubishi Electric Europe B.V. Polish Branch ul. Krakowska 50, 32-083 Balice, Poland TEL: +48(0)12-347-65-00
Ireland Mitsubishi Electric Europe B.V. Plunkett House,Grange Castle Business Park,Nangor Road, Dublin 22 TEL: +353 (0)1-4198800	Netherlands, Belgium and Luxemburg Mitsubishi Electric Europe B.V. Beechavenue 111, NL-1119 RB Schiphol-Rijk TEL: +31 (0) -297-250-350	Hungary Mitsubishi Electric Europe B.V. Hungarian Branch 2040 Budaors, Szabadsag ut 117 TEL: +36-70-3322-372
Sweden Mitsubishi Electric Europe B.V. Sweden Branch Hedvig Mollers gata 6 223 55 Lund TEL: +46(0)8-625-10-84	Turkey Mitsubishi Electric Europe B.V. Turkey Branch Serifali Mahallesi. Kale Sok. No:41, 34775 Umraniye / ISTANBUL TEL: +90(0)216/969-25-00	India MITSUBISHI ELECTRIC INDIA PRIVATE LIMITED ICC Devi Gaurav Technology park, Unit no 4+B12:D2902 4th floor, Pimpri Pune -411018 Maharashtra India TEL: +91-020-46242227



Mitsubishi Electric's e-F@ctory concept utilizes both FA and IT technologies, to reduce the total cost of development, production and maintenance, with the aim of achieving manufacturing that is a "step ahead of the times". It is supported by the e-F@ctory Alliance Partners covering software, devices, and system integration, creating the optimal e-F@ctory architecture to meet the end users needs and investment plans.



MITSUBISHI ELECTRIC CORPORATION

HEAD OFFICE: TOKYO BLDG., 2-7-3 MARUNOUCHI,
CHIYODA-KU, TOKYO 100-8310, JAPAN