

## Cross-Beam Area Sensors

# BWC Series

## INSTRUCTION MANUAL

TCD210005AC

**Autonics**

Thank you for choosing our Autonics product.

**Read and understand the instruction manual and manual thoroughly before using the product.**

**For your safety, read and follow the below safety considerations before using.**

**For your safety, read and follow the considerations written in the instruction manual, other manuals and Autonics website.**

Keep this instruction manual in a place where you can find easily.

The specifications, dimensions, etc. are subject to change without notice for product improvement. Some models may be discontinued without notice.

Follow Autonics website for the latest information.

### Safety Considerations

- Observe all 'Safety Considerations' for safe and proper operation to avoid hazards.
- ⚠ symbol indicates caution due to special circumstances in which hazards may occur.

**⚠ Warning** Failure to follow instructions may result in serious injury or death.

**01. Fail-safe device must be installed when using the unit with machinery that may cause serious injury or substantial economic loss. (e.g. nuclear power control, medical equipment, ships, vehicles, railways, aircraft, combustion apparatus, safety equipment, crime/disaster prevention devices, etc.)**

Failure to follow this instruction may result in personal injury, economic loss or fire.

**02. Do not use the unit in the place where flammable/explosive/corrosive gas, high humidity, direct sunlight, radiant heat, vibration, impact, or salinity may be present.**

Failure to follow this instruction may result in explosion or fire.

**03. Do not connect, repair, or inspect the unit while connected to a power source.**

Failure to follow this instruction may result in fire.

**04. Check 'Connections' before wiring.**

Failure to follow this instruction may result in fire.

**05. Do not disassemble or modify the unit.**

Failure to follow this instruction may result in fire.

**06. This product is not safety sensor and does not observe any domestic nor international safety standard.**

Do not use this product with the purpose of injury prevention or life protection, as well as in the place where economic loss maybe present.

**⚠ Caution** Failure to follow instructions may result in injury or product damage.

**01. Use the unit within the rated specifications.**

Failure to follow this instruction may result in fire or product damage.

**02. Use a dry cloth to clean the unit, and do not use water or organic solvent.**

Failure to follow this instruction may result in fire.

**03. Do not use a load over the range of rated relay specification.**

Failure to follow this instruction may result in fire, relay broken, contact melt, insulation failure or contact failure.

### Cautions during Use

- Follow instructions in 'Cautions during Use'. Otherwise, It may cause unexpected accidents.
- 12 - 24 VDC power supply should be insulated and limited voltage/current or Class 2, SELV power supply device.
- Use the product, 1 sec after supplying power. When using separate power supply for the sensor and load, supply power to sensor first.
- When using switching mode power supply to supply the power, ground F.G. terminal and connect a condenser between 0 V and F.G. terminal to remove noise.
- When connecting a DC relay or other inductive load, remove surge by using diodes or varistors.
- Wire as short as possible and keep away from high voltage lines or power lines, to prevent surge and inductive noise.
- This unit may be used in the following environments.
  - Indoors (in the environment condition rated in 'Specifications')
  - Altitude max. 2,000 m
  - Pollution degree 2
  - Installation category II

### Cautions during Installation

- Be sure to install this product by following the usage environment, location, and specified ratings. Consider the listed conditions below.
  - Installation environment and background (reflected light)
  - Sensing distance and sensing target
  - Direction of target's movement
  - Feature data
- If the installation environment has reflected light from the wall or floor, a interval distance of at least 0.5 m is required.
- When installing multiple sensors closely, it may result in malfunction due to mutual interference. Install it by referring to the interference protection and the installation method in the manual.
- Do not use in places where the light-receiving sensor is exposed to direct sunlight or where the ambient illumination is higher than the specification.
- Do not impact with a hard object or bend the cable excessively. That could decrease the product's water resistance.
- Use this product after the test. Check whether the indicator works appropriately for the positions of the detectable object.

### Ordering Information

This is only for reference, the actual product does not support all combinations. For selecting the specified model, follow the Autonics website.

<b>BWC</b>	<b>①</b>	<b>-</b>	<b>②</b>	<b>③</b>
------------	----------	----------	----------	----------

- ① Optical axis pitch**  
Number: Optical axis pitch (unit: mm)
- ② Number of optical axes**  
Number: 4 to 20
- ③ Operation mode**  
H: Light ON  
HD: Dark ON

### Product Components

- Product × 1
- Instruction manual × 1
- Bracket A × 4
- Bracket B × 4
- Fixing bolt × 8

### Sold Separately

- M12 Connector cable: CID4-□□(R) (1 set - emitter and receiver)

### Connections

- Pin number:

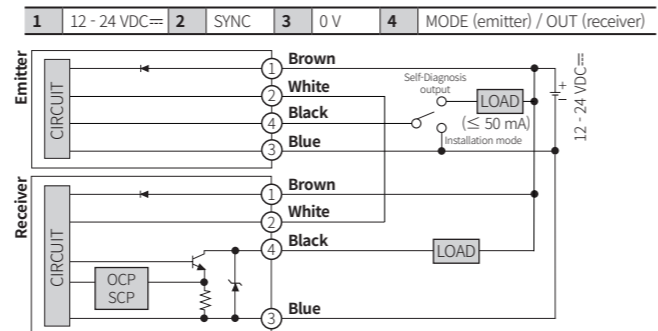

• OCP (over current protection), SCP (short circuit protection)

### Operation Indicator

☀ ON	🔴	Flashing at 0.5 sec interval	🔴🔴	Cross-flashing at 0.5 sec interval
● OFF	🔴🔴🔴	Flashing simultaneously at 0.5 sec interval	🔴🔴🔴	Sequence flashing at 0.5 sec interval

Item	Emitter indicator				Receiver			Control output	
	Green	Red	Green	Yellow	Red	Light ON	Dark ON		
Power ON	☀	●	-	-	-	-	-		
Break of emitter	🔴🔴	🔴🔴	🔴🔴	🔴🔴	🔴🔴	🔴🔴	🔴🔴	OFF	OFF
Break of emitting element	🔴	🔴	🔴	🔴	🔴	🔴	🔴	OFF	OFF
Installation mode	Normal installation	●	🔴	☀	●	🔴			
	Hysteresis section	●	🔴	●	☀	🔴	OFF	OFF	
	Abnormal installation	●	🔴	●	●	🔴			
Stable light ON	☀	●	☀	●	●	ON	OFF		
Unstable light ON	☀	●	☀	☀	●	ON	OFF		
Unstable light OFF	●	☀	●	☀	☀	OFF	ON		
Stable light OFF	●	☀	●	●	☀	OFF	ON		
Break of receiver	-	-	🔴🔴	🔴🔴	🔴🔴	OFF	OFF		
Control output over current	-	-	🔴	🔴	☀	OFF	OFF		
Malfunction of synchronous line	-	-	🔴	●	🔴	OFF	OFF		
Failure of emitter (time out)	-	-	🔴	🔴	🔴	OFF	OFF		
Failure of receiver (time out)	🔴	🔴	-	-	-	OFF	OFF		

### Dimensions

- Unit: mm, For the detailed drawings, follow the Autonics website.

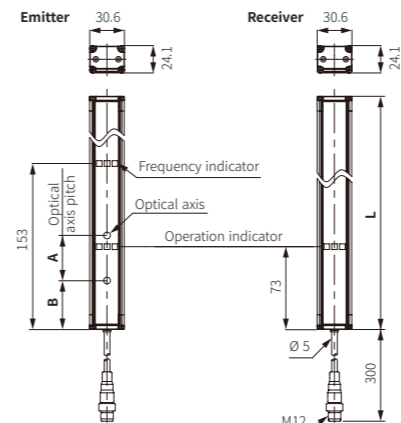

Model	Number of optical axis	Sensing height	L	A	B
BWC40-04H/HD	4	120 mm	186	40	43
BWC40-10H/HD	10	360 mm	426		
BWC40-12H/HD	12	440 mm	506		
BWC40-16H/HD	16	600 mm	666		
BWC40-18H/HD	18	680 mm	746		
BWC40-20H/HD	20	760 mm	826		
BWC80-14H/HD	14	1,040 mm	1146	80	83

### Bracket A

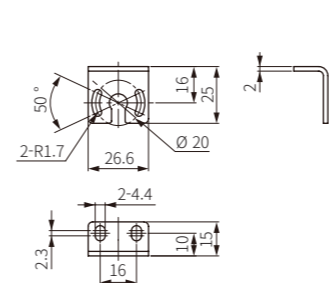

### Bracket B

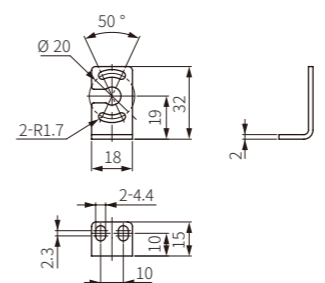

### Operation Timing Chart

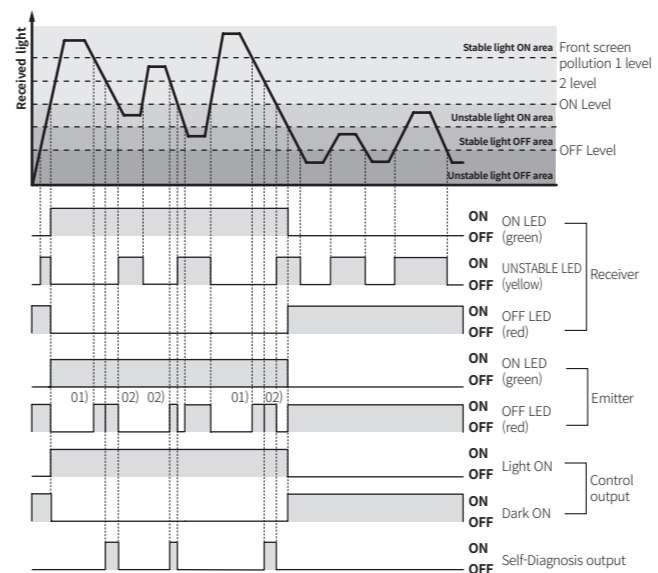

01) [Self-diagnosis output] Front screen pollution level 1 / flashing at 1 sec interval  
02) [Self-diagnosis output] Front screen pollution level 2, covering optical axis / flashing at 0.25 sec interval

### Installation Mode

This function is for stable installation.

For the first installation, enter installation mode.

- Inputting 0 V to 4th terminal (black, MODE) of emitter, supply power to the product to enter to the installation mode.
- After entering installation mode, install the unit at the position where green LED of receiver operation indicator turns ON.
- After installation, disconnect 4th terminal (black, MODE) of emitter and re-supply power to the unit.

### Specifications

Model	BWC40-□□H	BWC40-□□HD	BWC80-14H	BWC80-14HD
Sensing method	Through-beam			
Beam pattern	3-point cross beam netting type			
Light source	Infrared LED (850 nm modulated light)			
Sensing distance	1.0 to 7.0 m			
Sensing target	Opaque material			
Min. sensing target	≥ 50 mm		≥ 90 mm	
Number of optical axes	4 / 10 / 12 / 16 / 18 / 20		14	
Sensing height	120 to 760 mm		1,040 mm	
Optical axis pitch	40 mm		80 mm	
Response time	≤ 50 ms			
Operation mode	Light ON	Dark ON	Light ON	Dark ON
Functions	Self-diagnosis output (front screen pollution, covering optical axis), self-diagnosis			
Installation mode	YES			
Interference protection	Interference protection by frequency changing setting			
Synchronization type	Timing method by synchronous line			
Indicator	Emitter: Operation indicator (green, red), frequency indicator (green) Receiver: Operation indicator (red, yellow, green)			
Approval	CE 标志	CE 标志	CE 标志	CE 标志
Korean Railway Standards	-			KRS SG 0068
Weight (packaged)	≈ 1.7 kg (≈ 2.1 kg) (based on BWC80-14H)			

Power supply	12 - 24 VDC (ripple P-P: ≤ 10 %)
Current consumption	≤ 100 mA
Control output	NPN open collector output
Load voltage	≤ 30 VDC
Load current	≤ 100 mA (self-diagnosis output: ≤ 50 mA)
Residual voltage	≤ 1 VDC
Protection circuit	Reverse power protection circuit, output short overcurrent protection circuit
Insulation resistance	≥ 20 MΩ (500 VDC = megger)
Noise immunity	± 240 V the square wave noise (pulse width: 1μs) by the noise simulator
Dielectric strength	Between the charging part and the case: 1,000 VAC ~ 50 / 60 Hz for 1 minute
Vibration	1.5 mm double amplitude at frequency of 10 to 55 Hz in each X, Y, Z direction for 2 hours
Shock	500 m/s <sup>2</sup> (≈ 50 G) in each X, Y, Z direction for 3 times
Ambient illuminance	Ambient light: ≤ 100,000 lx
Ambient temperature	-10 to 55 °C, storage: -20 to 60 °C (no freezing or condensation)
Ambient humidity	35 to 85 %RH, storage: 35 to 85 %RH (no freezing or condensation)
Protection rating	IP67 (IEC standard)
Wire spec.	Ø 5 mm, 4-wire, 300 mm
Connector spec.	M12 plug connector
Material	Case: AL, sensing part and indicator: acryl

### Troubleshooting

Malfunction	Cause	Troubleshooting
Non-operation	Power supply	Supply the rated power.
	Cable incorrect connection, or disconnection	Check the wiring connection
Non-operation in sometimes	Out of rated sensing distance	Use it within rated sensing distance.
	Pollution by dirt of sensor cover	Remove dirt by soft brush or cloth.
Control output is OFF even though there is not a target object.	Connector connection failure	Check the assembled part of the connector.
	There is an obstacle to cut off the emitted light between emitter and receiver.	Remove the obstacle.
Operation indicator displays break of emitter	Out of the rated sensing distance	Use it within the rated sensing distance.
	There is strong electric wave or noise generator such as motor, electric generator, or high voltage line, etc.	Put away the strong electric wave or noise generator.
Operation indicator displays break of receiver	Break of emitter	Please contact customer service center.
Operation indicator displays break of emitting element	Break of receiver	
Operation indicator displays failure of emitter/receiver	Break of emitting element	Please contact customer service center.
	Emitter or Receiver failure	
Check the wiring connection in emitter and receiver.	There is strong electric wave or noise generator such as motor, electric generator, or high voltage line, etc.	Check the wiring connection in emitter and receiver.
	Bad wiring connection of synchronous cable in emitter and receiver	
Check the wiring connection in emitter and receiver.	Control output line is shorted out.	Check the wiring connection.
	Over load	Check the rated load capacity.