

Ø 22/25 mm I/O Push Button Switches



S2TR Series PRODUCT MANUAL

For your safety, read and follow the considerations written in the instruction manual, other manuals and Autonics website.

The specifications, dimensions, etc. are subject to change without notice for product improvement. Some Models may be discontinued without notice.

Features

- Smooth operation
- High electrical conductivity
- Long-lasting durability

Safety Considerations

- Observe all 'Safety Considerations' for safe and proper operation to avoid hazards.
- ⚠ symbol indicates caution due to special circumstances in which hazards may occur.

⚠ Warning Failure to follow instructions may result in serious injury or death.

- 01. Fail-safe device must be installed when using the unit with machinery that may cause serious injury or substantial economic loss. (e.g. nuclear power control, medical equipment, ships, vehicles, railways, aircraft, combustion apparatus, safety equipment, crime / disaster prevention devices, etc.)**
Failure to follow this instruction may result in personal injury, economic loss or fire.
- 02. Do not use or store the unit in the place where flammable / explosive / corrosive gas, high humidity, direct sunlight, radiant heat, vibration, impact, or salinity may be present.**
Failure to follow this instruction may result in explosion or fire.
- 03. Install on a device panel to use.**
Failure to follow this instruction may result in fire or electric shock.
- 04. Do not connect, repair, or inspect the unit while connected to a power source.**
Failure to follow this instruction may result in fire or electric shock.
- 05. Do not disassemble or modify the unit.**
Failure to follow this instruction may result in fire or electric shock.

⚠ Caution Failure to follow instructions may result in injury or product damage.

- 01. This unit shall not be used outdoors.**
Failure to follow this instruction may result in shortening the life cycle of the product or electric shock.
- 02. Use the unit within the rated specifications.**
Failure to follow this instruction may result in fire or product damage.
- 03. Do not use the load beyond rated switching capacity contact.**
Failure to follow this instruction may result in fire, relay broken, contact melt, insulation failure or contact failure.
- 04. For wiring the product, do not pull the wiring excessively or apply excessive force.**
Failure to follow this instruction may result in product damage or malfunction.
- 05. Use dry cloth to clean the unit, and do not use water or organic solvent.**
Failure to follow this instruction may result in fire or electric shock.
- 06. Keep the product away from metal chip, dust, and wire residue which from flowing into the unit.**
Failure to follow this instruction may result in fire or product damage.

Specifications

Series	S2TR Series
Actuation distance	5.0 to 5.5 mm
Actuation force	0.5 kgf (4.9 N) (per 1 contact)
Installation	Extended
Shock	300 m/s ² (≈ 30 G) in each X, Y, Z direction for 3 times
Shock (malfunction)	100 m/s ² (≈ 10 G) in each X, Y, Z direction for 3 times
Vibration	1.5 mm double amplitude at frequency of 10 to 55 Hz in each X, Y, Z direction for 2 hours
Vibration (malfunction)	1.5 mm double amplitude at frequency of 10 to 55 Hz in each X, Y, Z direction for 10 minutes
Mechanical life cycle (control unit life cycle)	≥ 1 million operations (20 operations/min)
Ambient temperature	-15 to 55 °C, storage: -25 to 65 °C (no freezing or condensation)
Ambient humidity	35 to 85 %RH, storage: 35 to 85 %RH (no freezing or condensation)
Protection structure	Control unit: IP50 (IEC standard)
Certification	CE UK cTUVus ENEC PS
Control unit weight	≈ 14.5 g
Housing weight	≈ 7 g

Contact blocks	
Power supply / current	110 VAC~ / 10 A, 250 VAC~ / 6 A
Dielectric strength	Between the charging part and the case : 3,000 VAC~ 50/60 Hz for 1 minute
Insulation resistance	≥ 1,000 MΩ (500 VDC== megger)
Contact resistance	≤ 20 mΩ (initial)
Electrical life cycle	≥ 100,000 operations (20 operations/min)
Contact material	AgNi10
Certification	CE UK cTUVus ENEC PS
Weight	Modular type: ≈ 10 g, Singular type: ≈ 11 g
LED blocks	
Rated voltage	AC/DC voltage type: 12-24 VAC~ 50/60 Hz, 12-24 VDC== AC voltage type: 110-220 VAC~ 50/60 Hz
Current consumption	≤ 20 mA
Certification	CE UK cTUVus ENEC
Weight	AC/DC voltage type: ≈ 11 g, AC voltage type: ≈ 12 g

Sold Separately

- Contact blocks (SA□-C□□)
- LED blocks (SA□-L□□□)
- Switch enclosures (SA-□B□)
- Locking handle (SA□-LH)
- Switch washer (SA-SW□)

Assembly / Disassembly

- Assembly order: ①→②→③→④
- Disassembly order: ④→③→②→①

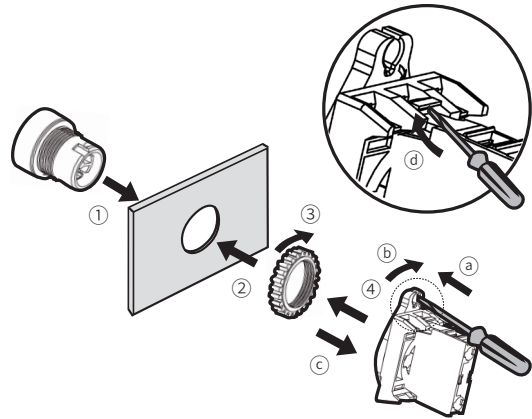

Control Switches	Panel thickness	Tightening torque
Ø 22/25/30 mm	Max. 6 mm	≤ 1.47 N·m

Ordering Information

This is only for reference. For selecting the specified Model, follow the Autonics website.

Model is based on control unit+block combination. Control units or blocks are sold separately. In case of block, refer to control switch accessories.

■ Non-illuminated

S2	1	-	2	3	4
Control unit			Block		

1 Switch type

TR: I/O push button switch (extended)

3 Contact block

2A: 2 A contacts
2B: 2 B contacts
AB: 1 A contact, 1 B contact

2 Illuminated

P1W: Non-illuminated

4 Block type

No mark: Singular type
M: Modular type

■ Illuminated

S2	1	-	2	3	4	5
Control unit			Block			

1 Switch type

TR: I/O push button switch (extended)

3 Contact block

2A: 2 A contacts
2B: 2 B contacts
AB: 1 A contact, 1 B contact

2 Illuminated

P3W: Illuminated

4 LED block

D: 1 AC/DC voltage type
L: 1 AC voltage type

5 Block type

No mark: Singular type
M: Modular type

Model	Contact block		LED block	
	A contact	B contact	AC/DC voltage	AC voltage
S2TR-P1W2A(M)	2	-	-	-
S2TR-P1W2B(M)	-	2	-	-
S2TR-P1WAB(M)	1	1	-	-

Model	Contact block		LED block	
	A contact	B contact	AC/DC voltage	AC voltage
S2TR-P3W2AD(M)	2	-	1	-
S2TR-P3W2AL(M)	2	-	-	1
S2TR-P3W2BD(M)	-	2	1	-
S2TR-P3W2BL(M)	-	2	-	1
S2TR-P3WABD(M)	1	1	1	-
S2TR-P3WABL(M)	1	1	-	1

Dimensions

- Unit: mm, For the detailed drawings, follow the Autonics website.
- Panel thickness: ≤ 6 mm

■ S2TR-□ (singular type block)

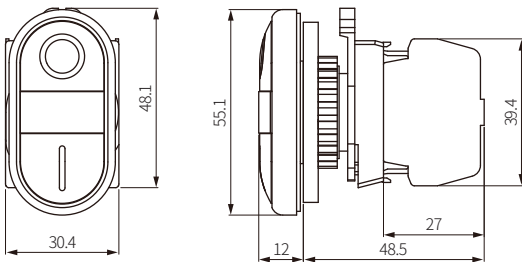

■ S2TR-□ M (modular type block)

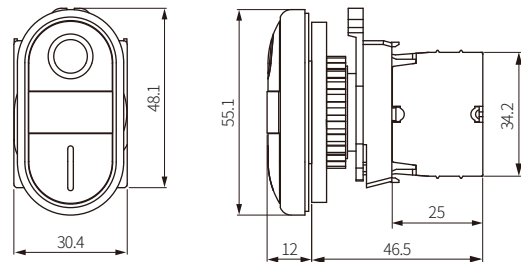

■ Panel cut-out

<Mounting round: Ø 25>

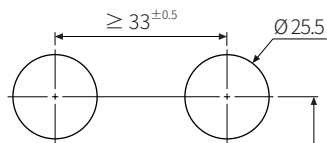



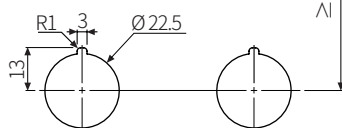

<Mounting round: Ø 22>



Ø 22/25 mm, Ø 30 mm, □ 30 mm Control Switches Accessories

Contact Blocks (SA□ -C□ □)

Model	Contact	Features	Applied switches	Appearance
SA-CAM	A contact (normally open)	<ul style="list-style-type: none"> Modular type Ring / Fork terminal available Modular connection (up to 3 units) 	Ø 22/25 mm, Ø 30 mm, □ 30 mm Control switches	
SA-CBM	B contact (normally closed)			
SA-CA	A contact (normally open)	<ul style="list-style-type: none"> Singular type (dust-resistant contact point) Fork terminal available Loose screw prevention 		
SA-CB	B contact (normally closed)			





Power supply / current	110 VAC~ / 10 A, 250 VAC~ / 6 A
Dielectric strength	Between the charging part and the case : 3,000 VAC~ 50/60 Hz for 1 minute
Insulation resistance	≥ 1,000 MΩ (500 VDC≡ megger)
Contact resistance	≤ 20 mΩ (initial)
Electrical life cycle	≥ 100,000 operations (20 operations/min)
Contact material	AgNi10
Certification	CE UK c-UL us ENEC
Weight	Modular type: ≈ 10 g, Singular type: ≈ 11 g

■ Removal

Separate the unit using a flat-head (-) screwdriver.



LED Blocks (SA□ -L□ □)

Model	Power supply	Features	Applied switches	Appearance
SA-LD□ M	AC/DC voltage type 12-24 VAC~ 50/60 Hz 12-24 VDC≡	<ul style="list-style-type: none"> Modular type Ring / Fork terminal available Modular connection (up to 3 units) 	Ø 22/25 mm, Ø 30 mm, □ 30 mm Control switches, Pilot lights	
SA-LA□ M	AC voltage type 110-220 VAC~ 50/60 Hz			
SA-LD□	AC/DC voltage type 12-24 VAC~ 50/60 Hz 12-24 VDC≡	<ul style="list-style-type: none"> Singular type (dust-resistant contact point) Fork terminal available Loose screw prevention 		
SA-LA□	AC voltage type 110-220 VAC~ 50/60 Hz			

□ : Color (R: Red / B: Blue / G: Green / Y: Yellow / W: White)

Rated voltage	AC/DC voltage type: 12-24 VAC~ 50/60 Hz, 12-24 VDC≡ AC voltage type: 110-220 VAC~ 50/60 Hz
Current consumption	≤ 20 mA
Certification	CE UK c-UL us ENEC
Weight	AC/DC voltage type: ≈ 11 g, AC voltage type: ≈ 12 g

■ Removal

Separate the unit using a flat-head (-) screwdriver. Same as contact removal method.

Locking Handle (SA□ -LH)





- For locking switch nuts behind the panels.

Model	Applied switches	Appearance
SA-LH	Ø 22/25 mm, Ø 30 mm, □ 30 mm Control switches, Pilot lights ⁰¹⁾	

01) Except Ø 30 mm round pressure switches (extended).

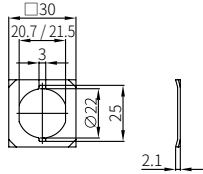
Switch Washer (SA-SW□)

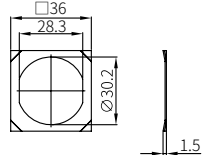
- The washer helps to improve switch tightening force.
- Unit: mm, For the detailed drawings, follow the Autonics web site.

Model	Applied switches	Dimensions	Appearance
SA-SW2	Ø 22/25 mm Control switches, Pilot lights		
SA-SW3	Ø 30 mm Control switches, Pilot lights		

Switch Enclosures (SA-□ B□)

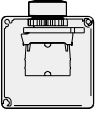
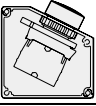
Model	Certification	Shape	Applied switches	Appearance
SA-SB□	CE	Square	Ø 22/25 mm Control switches	
SA-TB□	CE	Triangle		

□ : Number of holes (1 to 5)

• You can order the other size and the number of holes.

■ Dimensions

• Unit: mm, For the detailed drawings, follow the Autonics web site.

Model	Holes	L
SA-□ B1	1	86
SA-□ B2	2	136
SA-□ B3	3	186
SA-□ B4	4	236
SA-□ B5	5	286

• SA-SB□

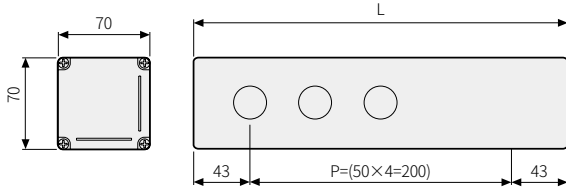



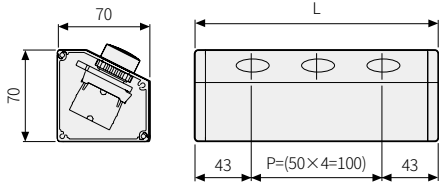

• SA-TB□

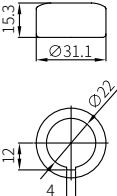

Switch Waterproof Cap (SA-W□)

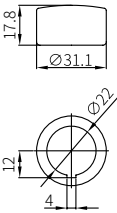
- IP65 protection structure with waterproof cap
- Unit: mm, For the detailed drawings, follow the Autonics web site.

Model	Applied switches	Dimensions	Appearance
SA-WP	Ø 22/25 mm Round non-illuminated / extended push button switches		
SA-WL	Ø 22/25 mm Round illuminated / extended push button switches		

Emergency Switch Nameplates (SA-N□)

- Unit: mm, For the detailed drawings, follow the Autonics web site.
- Standard color is yellow. Luminous nameplates are optional.

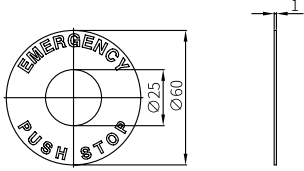
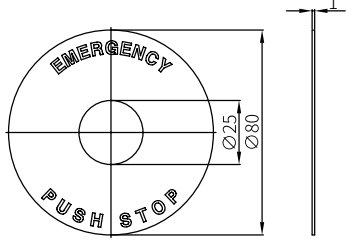
Model	Applied switches	Appearance
SA-NS	Ø 22/25 mm Emergency switches ⁰¹⁾	<ul style="list-style-type: none"> • D60 × d25 
SA-NL	Ø 22/25 mm Emergency switches	<ul style="list-style-type: none"> • D80 × d25 

01) Except Ø 22/25 mm Emergency switch D60.

Emergency Switch Protective Shrouds (SA-EG□)

- Protective shrouds to prevent accidental/incorrect operation.

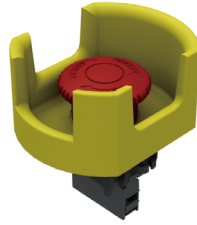
Model	Applied switches	Appearance
SA-EG1	Ø 22/25 mm Emergency switches ⁰¹⁾	
SA-EG2 / SA-EG3		

01) Except Ø 22/25 mm Emergency switch D60.

■ Dimensions

- Unit: mm, For the detailed drawings, follow the Autonics web site.
- SA-EG1

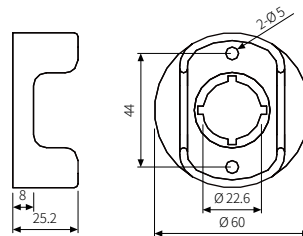

- SA-EG2 / EG3

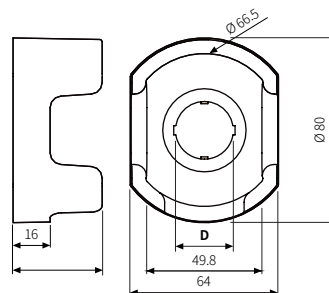

Model	D
SA-EG2	Ø 22.5
SA-EG3	Ø 25.5